



This is a digital copy of a book that was preserved for generations on library shelves before it was carefully scanned by Google as part of a project to make the world's books discoverable online.

It has survived long enough for the copyright to expire and the book to enter the public domain. A public domain book is one that was never subject to copyright or whose legal copyright term has expired. Whether a book is in the public domain may vary country to country. Public domain books are our gateways to the past, representing a wealth of history, culture and knowledge that's often difficult to discover.

Marks, notations and other marginalia present in the original volume will appear in this file - a reminder of this book's long journey from the publisher to a library and finally to you.

Usage guidelines

Google is proud to partner with libraries to digitize public domain materials and make them widely accessible. Public domain books belong to the public and we are merely their custodians. Nevertheless, this work is expensive, so in order to keep providing this resource, we have taken steps to prevent abuse by commercial parties, including placing technical restrictions on automated querying.

We also ask that you:

- + *Make non-commercial use of the files* We designed Google Book Search for use by individuals, and we request that you use these files for personal, non-commercial purposes.
- + *Refrain from automated querying* Do not send automated queries of any sort to Google's system: If you are conducting research on machine translation, optical character recognition or other areas where access to a large amount of text is helpful, please contact us. We encourage the use of public domain materials for these purposes and may be able to help.
- + *Maintain attribution* The Google "watermark" you see on each file is essential for informing people about this project and helping them find additional materials through Google Book Search. Please do not remove it.
- + *Keep it legal* Whatever your use, remember that you are responsible for ensuring that what you are doing is legal. Do not assume that just because we believe a book is in the public domain for users in the United States, that the work is also in the public domain for users in other countries. Whether a book is still in copyright varies from country to country, and we can't offer guidance on whether any specific use of any specific book is allowed. Please do not assume that a book's appearance in Google Book Search means it can be used in any manner anywhere in the world. Copyright infringement liability can be quite severe.

About Google Book Search

Google's mission is to organize the world's information and to make it universally accessible and useful. Google Book Search helps readers discover the world's books while helping authors and publishers reach new audiences. You can search through the full text of this book on the web at <http://books.google.com/>



Library
of the
University of Wisconsin

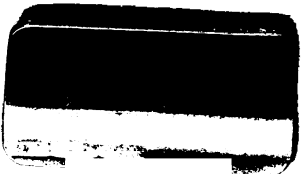

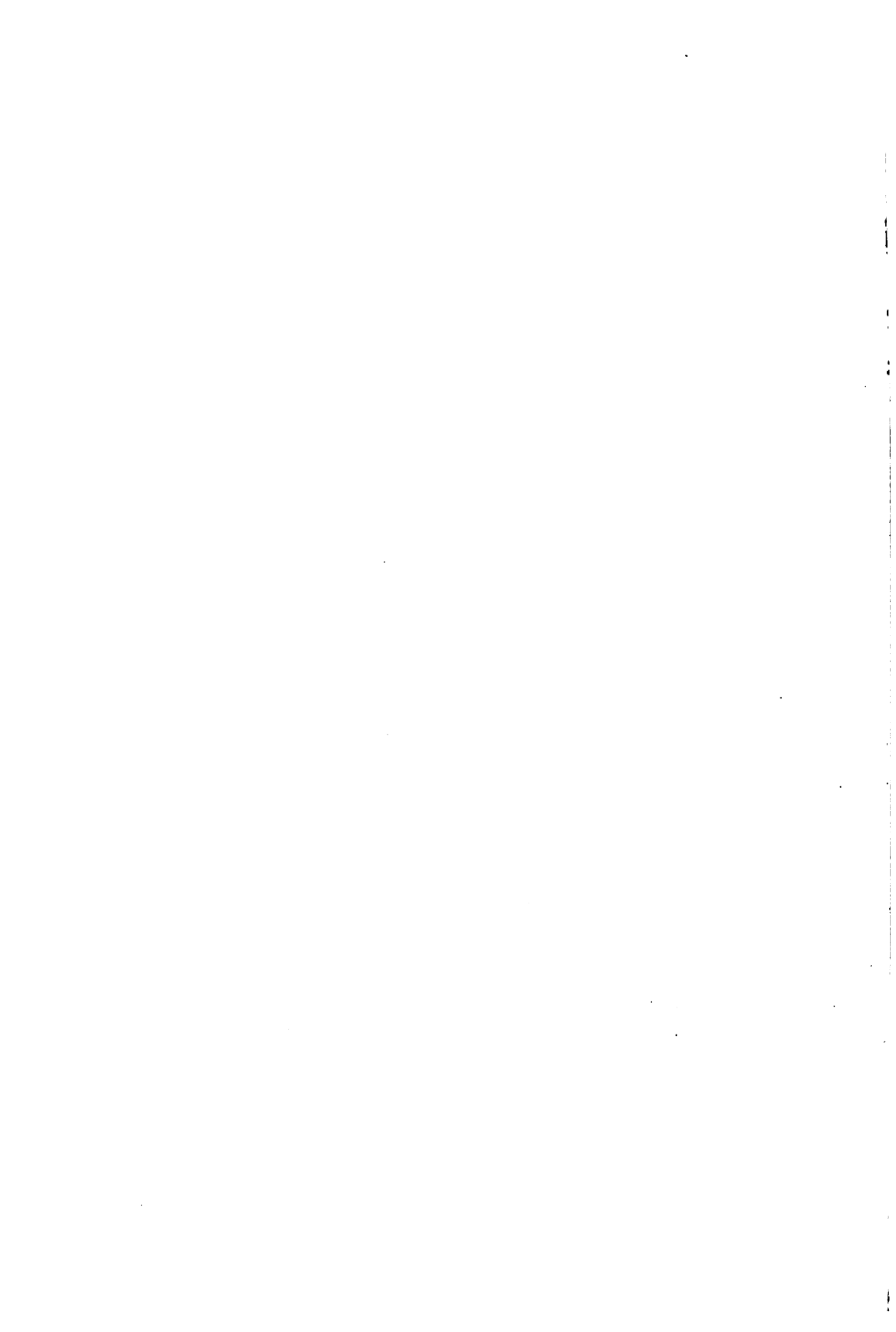

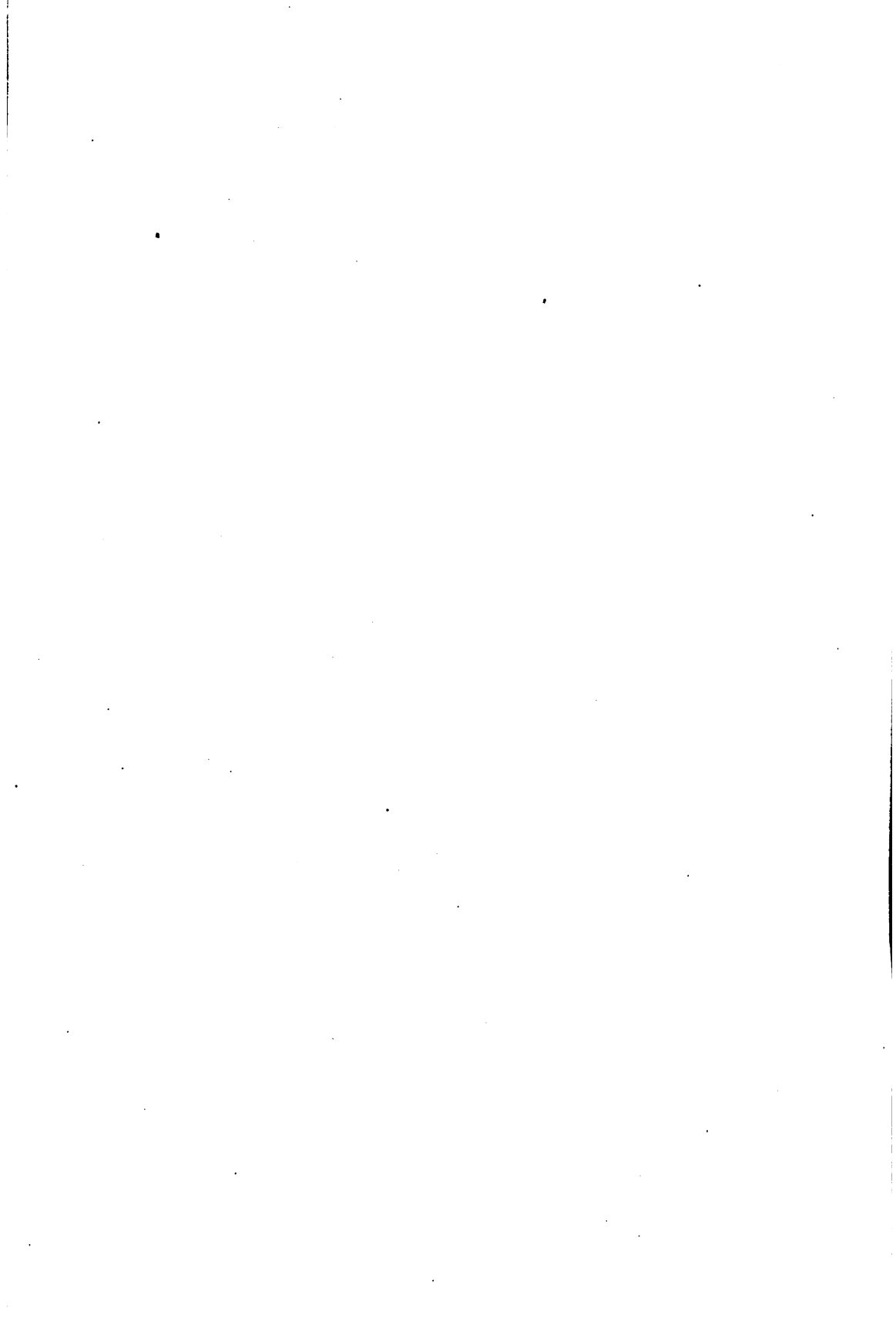

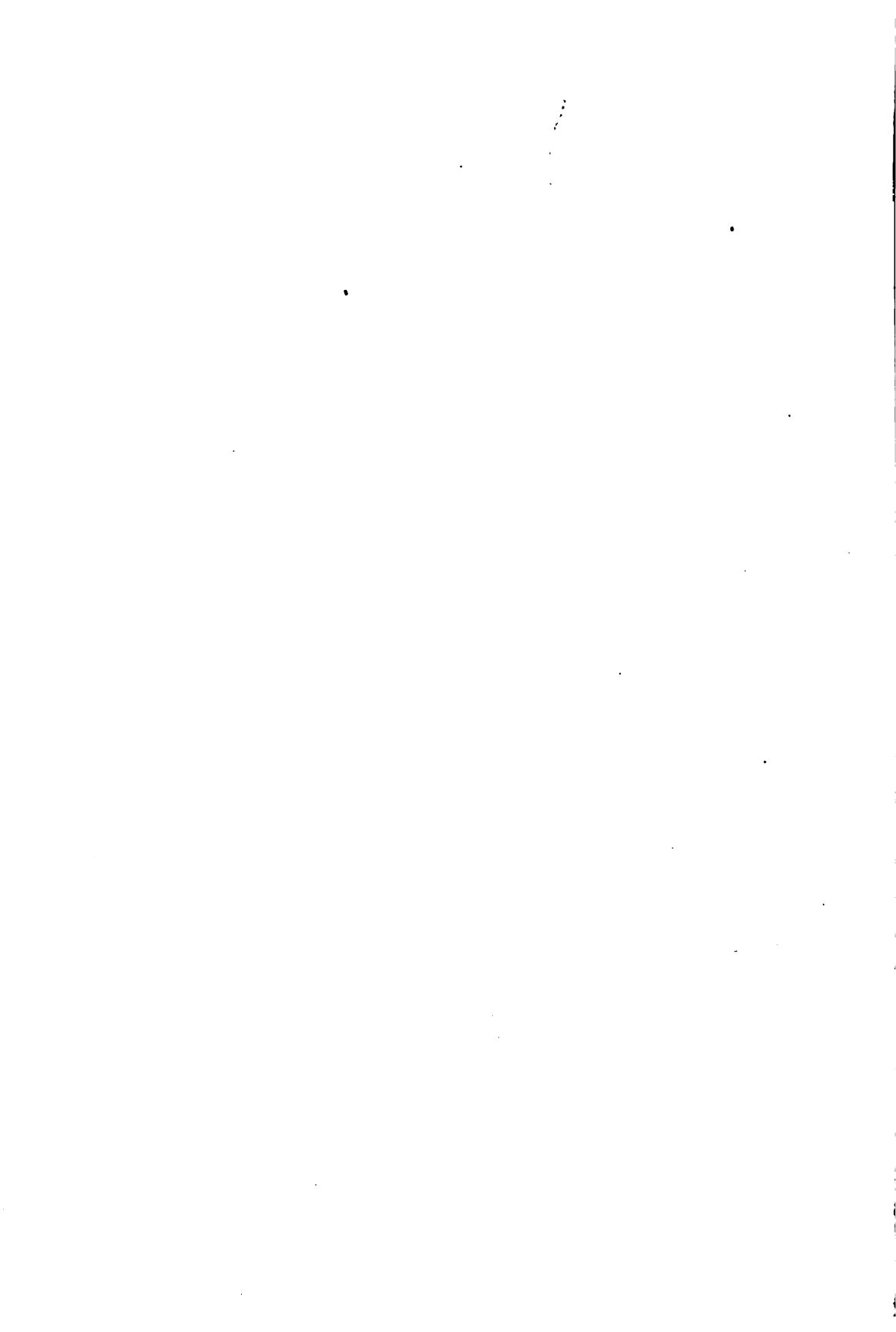

AIR COMPRESSION AND TRANSMISSION

McGraw-Hill Book Company

Publishers of Books for

Electrical World	The Engineering and Mining Journal
Engineering Record	Engineering News
Railway Age Gazette	American Machinist
Signal Engineer	American Engineer
Electric Railway Journal	Coal Age
Metallurgical and Chemical Engineering	Power

AIR COMPRESSION AND TRANSMISSION

BY

H. J. THORKELSON

ASSOCIATE PROFESSOR STEAM AND GAS ENGINEERING
UNIVERSITY OF WISCONSIN

McGRAW-HILL BOOK COMPANY
239 WEST 39TH STREET, NEW YORK
6 BOUVERIE STREET, LONDON, E. C.
1913

**COPYRIGHT, 1913, BY THE
MCGRAW-HILL BOOK COMPANY**

THE MAPLE PRESS YORK PA

Eng)
TEP
.T39
.2

686074
ac

HWX7783

PREFACE

This text is designed to present in logical order the fundamental principles dealing with the subject of the compression of air, and its transmission through ducts or pipes, together with such examples as will serve to illustrate their application.

It is hoped that the presentation will make clear the methods to be followed in calculations dealing with air at various pressures, and that students and engineers will be better able to appreciate the advantages and limitations of the various systems of securing the pressures desired, and of using air as a means of transmitting energy, or for securing certain results which cannot be obtained under normal atmospheric pressure.

The material offered consists of notes used for a number of years by the author in his classes. He wishes to acknowledge his indebtedness to the many excellent texts on the subject which have been published, notably those of Richards, Saunders, Hiscox, Harris and Peele.

The fundamental formulæ are to be found in most texts on Thermodynamics for Engineers. The author is particularly indebted to Prof. C. H. Peabody's text on this subject, and to the lectures of F. W. O'Neill, F. D. Longacre, H. deB. Parsons and F. W. Towl, given at Columbia University in a course on Applied Thermodynamics of Air Compressors. The material on turbo-compressors is taken from articles on this subject in recent numbers of the Engineering Magazine by Franz zur Nedden. Permission to use this material has been courteously granted by these authors and their publishers.

The author is also indebted to the editors of Compressed Air Magazine and to various manufacturers for cuts, and to his colleagues, particularly Prof. A. G. Christie and Mr. W. C. Rowse, for assistance in preparing this text.

H. J. T.

April, 1913.

11
from the notes in the
text.



INTRODUCTION

HISTORICAL ACCOUNT OF MECHANICAL USES OF AIR

The earliest writings describing mechanical uses of air are found in a book entitled "Pneumatics" by Hero of Alexandria, published about 200 B. C. An English translation of this by Bennet Woodcroft indicates a very complete knowledge of many mechanical devices possessed by the Ancients, and shows various pumps, Hero's steam turbine and many remarkable uses of air as a means of transmitting energy.

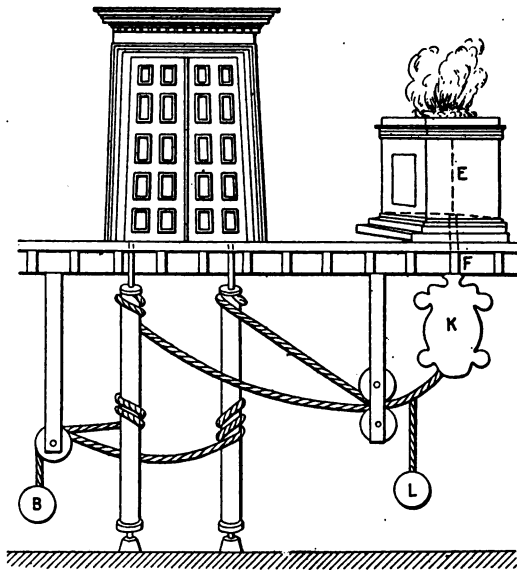

FIG. 1.—Hero's device for opening temple doors.

One of the most interesting illustrations is a device for opening temple doors by fire on an altar illustrated in Fig. 1. The altar, *E* is hollow and a tube *F* passes through the altar and is attached to a leather bag, *K*. Beneath this a small weight *L* is suspended which is connected to the bag and to the pivots of the temple doors as shown. Weights *L* and *B* are so proportioned as to normally

close the doors. When a fire is lighted on the altar, the bag *K* will expand under the pressure of the heated air below the altar and, in doing so lift the weight *L*. Weight *B* then falls and causes the doors to open. If the fire is extinguished, the air under the altar will cool, contract, and the bag *K* will take the position indicated and weight *B* will be dropped, causing the doors to close.

A somewhat similar device is also described in the same text using heated air under a similar altar to force water from one chamber into a pail, thus counterbalancing the weight and causing the temple doors to open. Many automatons are also described, in which air is made use of to produce musical notes and cause water to flow from vessels or objects when certain changes in the mechanism take place.

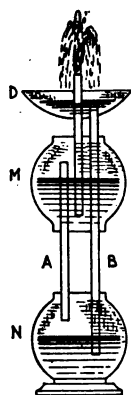

FIG. 2.—Hero's fountain.

A very interesting experiment, illustrated in most texts on physics, called "Hero's Fountain" and invented by the author of the book "Pneumatics," consists of two globes, Fig 2, *M* and *N*, and a brass dish, *D*. The dish *D* communicates with the lower part of the globe *N* by a tube *B* and another tube *A* connects the two globes. A third tube passes through the dish *D* to the lower part of the globe *M*. This tube having been taken out, the globe *M* is partially filled with water, the tube is then replaced and water is poured into the dish. The water flows through the tube *B* into the lower globe and expels the air which is forced into the upper globe. The air being compressed acts upon the water and makes it jet out as shown. If it were not for the resistance of the atmosphere and friction, the liquid would rise to a height above the water in the dish equal to the difference of the level of the water between the two globes.

Although a knowledge of this wonderful method of transmitting energy has been known for centuries, it is only within comparatively recent years that it has been used to any considerable extent in practical work. Its modern use dates from the construction of the Mt. Cenis tunnel completed in 1871. The work on this tunnel, which is about 8 miles long, had progressed very slowly from 1857 to 1861, the tunnel headings having been drilled by hand labor with an average advance in each of the two headings of about 1 1/2 ft. per day. Machine drills driven by compressed air were introduced and the speed rose to 4 3/4 ft. per day, and later when dynamite was

introduced, the cut was increased to 6 ft. per day. Sommeiller deserves the honor for solving, in this work, many of the initial problems of compressed-air production and use. The type of compressor used is illustrated in Fig. 3. A natural supply of water was used for compressing the air. The water was conducted in a sluice *A* through a valve *C*, compressing the air which is in *D* and forcing it into the reservoir *E*. When this was done the valve *C* was automatically closed and the water in *D* allowed to escape and be replaced by a new supply of air at atmospheric pressure. This

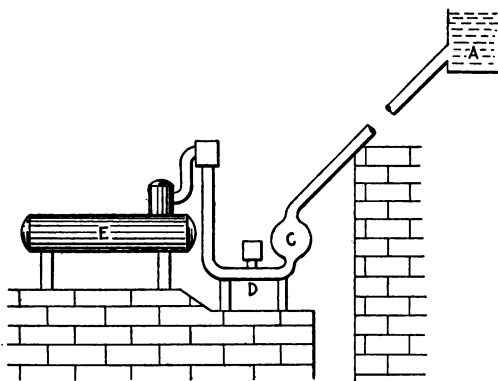

FIG. 3.—Sommeiller's compressor.

was in turn compressed and forced into the reservoir *E*, giving not a continuous but an intermittent flow of air. This compressor furnished air at 80-lb. pressure, but only gave an efficiency of 50 per cent., that is, only one-half of the available energy was turned into useful work.

Although the value of compressed air for machine drills for tunnel work was clearly demonstrated in the building of Mt. Ceniz tunnel, it was some time before this was applied to mining work. One of the earliest tests for mining work was made at the Calumet and Hecla copper mine in Michigan in 1878, and the advantages in lower costs and higher speeds were so clearly demonstrated that its use for this work has since become almost universal.

One of the most important of modern applications of compressed air is to be found in the braking of trains. George Westinghouse, in 1869, designed his first "straight air brake," which was later changed to the "automatic" type of air brake. This apparatus has

been improved and perfected to such an extent that its operation is truly marvelous and its application world wide.

Railroad men were among the first to appreciate the uses of compressed air in shop and structural work, and its application to manufacture and other allied arts has since become so universal that a mere recital of the modern applications of compressed air would become tedious. One of the largest manufacturers of air compressors has recently published a partial list of various applications of compressed air for which they have furnished compressors. This list includes over sixty different industries, with a great many different uses of compressed air in each.

While compressed air has many advantages over other systems of transmitting energy, it has also certain disadvantages and limitations which should be clearly understood. In order to appreciate these, it is necessary to study in detail the nature and characteristics of air and the fundamental principles governing its generation, distribution, and application.

CONTENTS

PREFACE	v
INTRODUCTION	vii
CHAPTER I	
CHARACTERISTICS OF AIR	i
Air—Vapor in air—Free air—Dry air—Effect of pressure on temperature.	
CHAPTER II	
FUNDAMENTAL DEFINITIONS	5
Work—Energy—Heat—Power—Temperature—Absolute temperature—B.t.u.—Effects of heat—Energy in air—Specific heat—Specific heat at constant pressure—Specific heat at constant volume—Real specific heat—Apparent specific heat.	
CHAPTER III	
CHARACTERISTIC AND ENERGY EQUATIONS FOR AIR	10
Boyle's law—Law of Charles—Characteristic equation for perfect gases—Numerical value of R —Weight of air—Relation between specific heats—Work of isothermal change—Exponential change—Work of adiabatic change—Relations between P , v and T for adiabatic and exponential change—Computation of intrinsic energy.	
CHAPTER IV	
GRAPHICAL DIAGRAMS	18
Construction of isothermal curves—Construction of exponential curves—Heat added or taken away for isothermal change—Heat added or taken away for exponential change—Difference between isothermal and adiabatic compression—Temperatures due to adiabatic compression—Work done by a compressor—Exponential compression—Isothermal compression.	
CHAPTER V	
AIR AT PRESSURES BELOW THE ATMOSPHERE	26
Venturi vacuum pump—Sprengle air pump—Measuring vacuums—Condenser pumps—Wheeler combined pump—Size of water and air pumps—Steam cylinder size—U. S. Navy air pumps—Edwards air pump—Industrial uses of vacuums—Salt evaporating effects—Concentration of liquids—Evaporation of cane juice—Vacuum cleaners—Syphon.	

CHAPTER VI

AIR AT LOW PRESSURES	38
Uses of air at low pressures—Compressors for low pressures—Air for forges—Air for cupolas—Air for ventilation—Fans or blowers—Classification—Definitions—Measurement of draft—Fan efficiency—Flow of gas through an orifice—Loss of head due to friction in ducts—Usual velocity in ducts—Notation of symbols—Pipe losses—Rotary blowing machines—Blower pressures and capacities—Power for rotary blowers—Mechanics of the fan—Effect of outlet on capacity—Work required to move a volume of gas—Design of fans—Description of fans—Centrifugal fans—Fan blast or steel plate machine—Housing—Cone wheel fans—Turbine blast or “Sirocco” fan.	

CHAPTER VII

PISTON COMPRESSORS	69
Action of piston compressor—Indicator card of piston compressor—Effect of clearance—Methods of reducing clearance—Suction line—Compression line—Wet and dry compression—Actual compression—Cards for air compressors.	

CHAPTER VIII

EFFICIENCIES AND ENERGY COMPENSATION	77
Volumetric Efficiency—Apparent volumetric efficiency—True volumetric efficiency—Cylinder efficiency—Efficiency of compression—Mechanical efficiency—Net efficiency—Blower efficiency—Energy compensation—Hydraulic compensator—Lever compensator—Weight compensator—Straight line compressor—Duplex compressor.	

CHAPTER IX

MULTI-STAGE COMPRESSION	89
Advantage of multi-stage compression—Pressures used for various stages—Intercoolers—Types of intercoolers—Cooling surface and capacity—Intercooler pressure—Effect of clearance on volumetric efficiency.	

CHAPTER X

DETAILS OF PISTON AIR COMPRESSORS	98
Classification of valves—Mechanical valves—Inlet valve setting—Effect of changing discharge pressure—Automatic valves—Valve area—Forms of Poppet valves—Piston-inlet valves—Semi-mechanical valves—Regulators, unloading devices, etc.—Belt regulator—Westinghouse governor—Norwalk regulator—Combined governor and regulator—Nordberg governor—Unloading devices—Clearance unloader.	

CHAPTER XI

TURBO-COMPRESSORS	113
Design of turbo-compressors—Rateau blower—The Parsons blower—	

Cooling turbo-compressors—Cooling devices—Expansion of casing—Runners—Balancing axial thrust—Balance by counter-position—Balancing by diminishing back area—Balancing by balancing piston—Stuffing-boxes—Coupling compressors—Rateau multiplier—Mixing blower.

CHAPTER XII

HYDRAULIC COMPRESSION OF AIR 129
 Trompe—Frizell's compressor—Baloche and Krahnass compressor—Arthur compressor—Taylor compressor—Taylor compressor at Magog, Quebec—Taylor compressor at Ainsworth, B. C.—Taylor compressor at Victoria Mine, Mich.—Phenomena of hydraulic air compression—Losses of hydraulic compression.

CHAPTER XIII

EFFECT OF ALTITUDE AND COMPRESSOR TESTS 140
 Effect of altitude on capacity—Effect of altitude on power—Relation between altitude and volume—Compressor tests—Mode of conducting the tests—Results of the tests—Tests of plant No. 1—Test of plant No. 2—Test of plant No. 3—Test No. 4—Summary.

CHAPTER XIV

RECEIVERS. MEASUREMENT AND TRANSMISSION OF COMPRESSED AIR . . 159
 Receivers—Measurement of air and gases—Standards of measurements—Volumetric meters—Velocity meters—St. John's meter—Venturi meter—Thomas meter—Meter comparisons—Pipe lines—Dresser coupler—Hammon coupler—Pipe-line formulæ—Reheating—Stoves.

CHAPTER XV.

THE SELECTION AND CARE OF AIR COMPRESSORS 179
 Available power—Valve gear—Size and type of compressor—Compressed air explosions—Lubricating compressors—Cleaning valves—Inlet connections.
 APPENDIX A—COMMON LOGARITHMS 184
 APPENDIX B—NAPERIAN LOGARITHMS 188
 APPENDIX C—HYGROMETRY 191
 INDEX 201

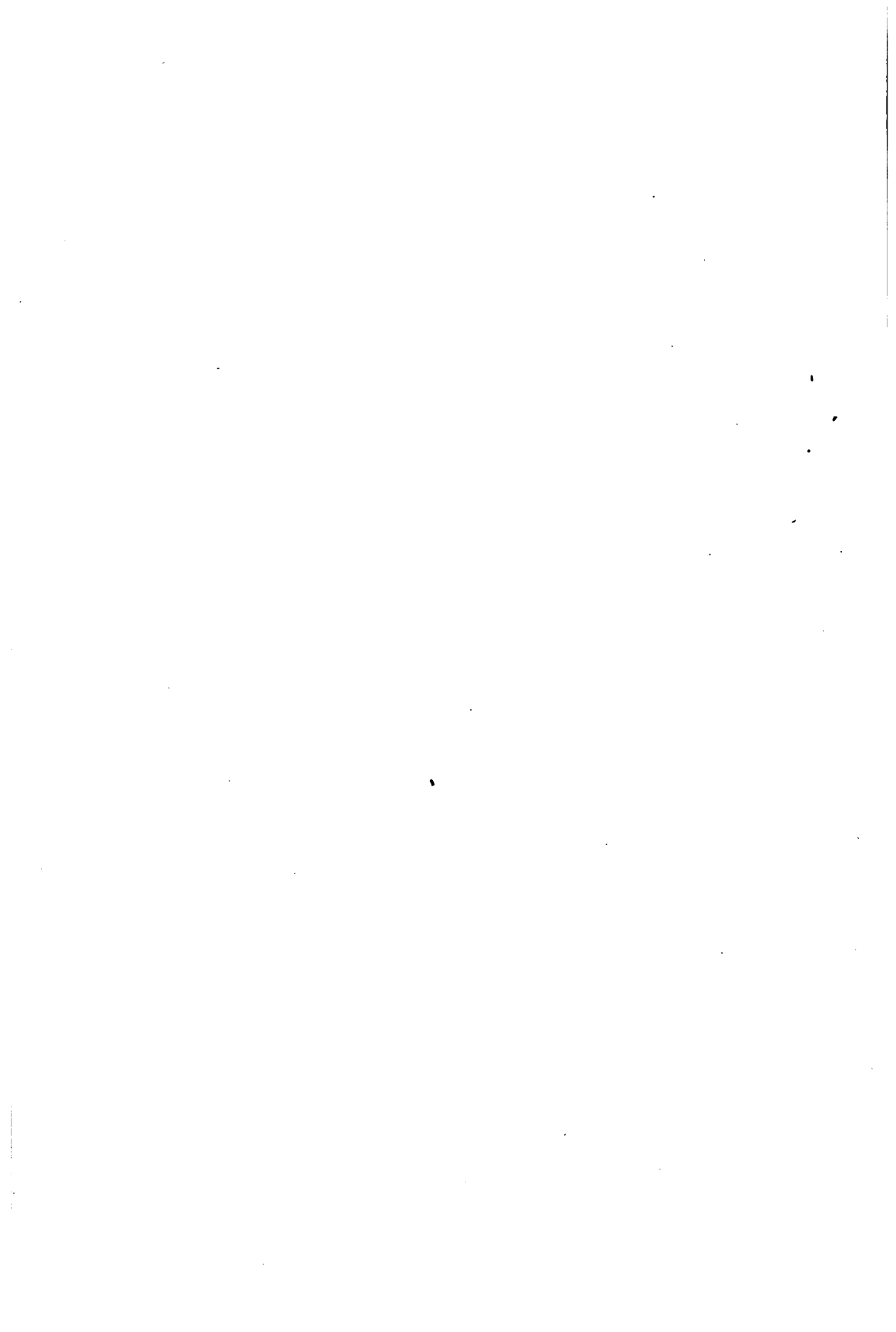

AIR COMPRESSION AND TRANSMISSION

CHAPTER I

CHARACTERISTICS OF AIR

Air.—Air is a mechanical mixture of several gases, principally oxygen and nitrogen, its average composition by volume being as follows:

Nitrogen.....	78.49
Oxygen.....	20.63
Aqueous vapor.....	0.84
Carbonic acid gas.....	0.04

By weight it contains about 77 parts of nitrogen to 23 parts of oxygen. There may be, in addition to the above, local impurities in the atmosphere, the principal ones being ammonia and sulphuretted hydrogen.

The carbonic acid gas arises principally from the respiration of animals and the processes of combustion, but, notwithstanding the enormous continual production of this gas, the composition of the atmosphere does not vary, for plants in the process of growth decompose the carbonic acid, assimilate the carbon, and restore to the atmosphere the oxygen, which is being continually consumed in the processes of respiration and combustion.

Vapor in Air.—The vapor of water is always present in the atmosphere and when the air contains as much of this vapor as it possibly can, it is said to be saturated.

The amount of vapor present in the air when saturated will vary with the temperature, as shown in Table I, taken from the Smithsonian Institution Reports.

TABLE I.—GRAINS VAPOR IN 1 CU. FT. OF AIR SATURATED WITH MOISTURE
(7,000 Grains = 1 lb. Avoir.)

Temp. Fahr.		1	2	3	4	5	6	7	8	9
0	0.481	0.505	0.529	0.554	0.582	0.610	0.639	0.671	0.704	0.739
10	0.776	0.816	0.856	0.898	0.941	0.985	1.032	1.079	1.128	1.181
20	1.235	1.294	1.355	1.418	1.483	1.551	1.623	1.697	1.773	1.853
30	1.935	2.022	2.113	2.194	2.279	2.366	2.457	2.550	2.646	2.746
40	2.849	2.955	3.064	3.177	3.294	3.414	3.539	3.667	3.800	3.936
50	4.076	4.222	4.372	4.526	4.685	4.849	5.018	5.191	5.370	5.555
60	5.745	5.941	6.142	6.349	6.563	6.782	7.009	7.241	7.480	7.726
70	7.980	8.240	8.508	8.782	9.066	9.356	9.655	9.962	10.277	10.601
80	10.934	11.275	11.626	11.987	12.356	12.736	13.127	13.526	13.937	14.359
90	14.790	15.234	15.689	16.155	16.634	17.124	17.626	18.142	18.671	19.212

This shows the number of grains of vapor present in each cubic foot of air when the air is saturated. As there are 7,000 gr. in a

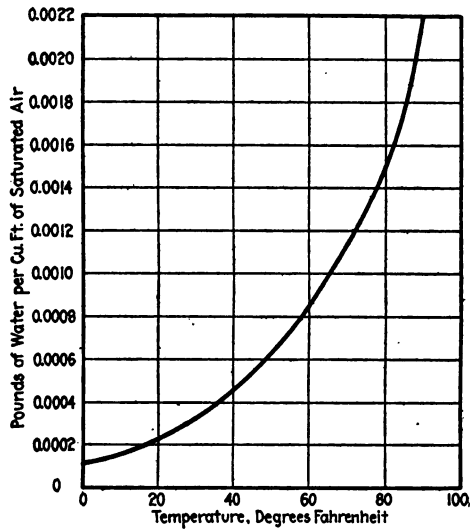

FIG. 4.—Water present in saturated air.

pound avoirdupois, these weights can be easily converted into pounds. This data is shown graphically in Fig 4.

Free Air.—Free air is air at the pressure and temperature of the atmosphere. This is a term used extensively in texts on compressed air and in rating the capacity of a compressor.

It can be shown experimentally (Boyle's Law) that if a cubic

foot of free air at sea-level (14.7 lb.) is compressed to a pressure of 44.1 lb. by the gauge, or 4 atmospheres absolute, and allowed to cool to the temperature of the atmosphere, the compressed air will occupy one-fourth its original volume; if compressed to a pressure of 58.8 lb. gauge, or 5 atmospheres absolute, and allowed to cool to the temperature of the atmosphere, it will occupy one-fifth of its original volume.

Figure 4 shows the weight of moisture which may be held in 1 cu. ft. of air at different temperatures, if saturated, and is true no matter what pressure the air may be under.

It is evident then, that if a volume of free saturated air be compressed into a smaller space and kept at the same temperature, part of the vapor it originally contained must be precipitated for the reason that 1 cu. ft. of air at a certain temperature can only hold a definite weight of vapor when saturated, whether compressed or at atmospheric pressure.

If saturated air is compressed to 5 atmospheres, or 73.5 lb. per square inch absolute, and allowed to cool to atmospheric temperature, its volume will be reduced to one-fifth of its original volume and 1 cu. ft. of compressed air will contain the moisture content of 5 cu. ft. of free air.

TABLE II.—POUNDS OF WATER PRECIPITATED PER CUBIC FOOT OF COMPRESSED AIR AFTER COMPRESSION AND COOLING OF SATURATED FREE AIR (Pressures)

Temp. of air	Ga. Abs. Atm.	29.4	44.1	58.8	102.9	147.0	367.5	735.0	2205.0
		44.1 3	58.8 4	73.5 5	117.6 8	161.7 11	382.2 26	749.7 51	2219.7 151
0		.0001	.0002	.0003	.0005	.0007	.0017	.0035	.0105
10		.0002	.0003	.0004	.0008	.0011	.0027	.0055	.0165
20		.0004	.0005	.0007	.0013	.0018	.0045	.0090	.0270
30		.0006	.0008	.0011	.0020	.0028	.0070	.0140	.0420
40		.0008	.0012	.0016	.0028	.0040	.0100	.0200	.0600
50		.0012	.0017	.0023	.0041	.0058	.0145	.0290	.0870
60		.0016	.0025	.0033	.0057	.0082	.0205	.0410	.1230
70		.0023	.0034	.0045	.0079	.0114	.0285	.0570	.1710
80		.0031	.0048	.0062	.0109	.0156	.0390	.0780	.2340
90		.0042	.0063	.0084	.0148	.0211	.0527	.1055	.3165

(For a further discussion on moisture in the air see Appendix C.)

When reduced to the temperature of the atmosphere, the moisture held in suspension per cubic foot of the compressed air cannot exceed the moisture held in suspension per cubic foot of the free air, and in consequence the remaining moisture will be precipitated. This will represent for each cubic foot of compressed air a weight of water equivalent to four times the weight held in suspension.

These weights have been calculated for various temperatures and pressures as shown in Table II.

Dry Air.—Air is said to be “dry” when water evaporates and moist objects dry rapidly, and the air is “moist” when they do not dry rapidly and when the least lowering of temperature brings about deposits of moisture. The terms are therefore relative ones, but the expression “dry air,” when used with reference to compressed air, is usually understood as air containing less than half the amount of moisture that is contained in “saturated” air.

Effect of Pressure on Temperature.—It is well known that air can be made to expand by the application of heat. The altar trick of the Egyptians illustrates this as does the modern hot-air engine. Before friction matches came into general use, fire was often produced by means of an air plunger-pump, which consisted of a cast-iron barrel weighing several pounds with a bore about $\frac{3}{8}$ in. in diameter, in which a steel piston fitted rather tightly. The end of the piston had a small cavity for receiving a piece of punk, and by pushing the barrel down on the piston the air in the barrel was compressed and its temperature rose high enough to ignite the punk. If heat is generated by compressing air, it is natural to expect that if compressed air be allowed to expand the temperature of the air will fall. This is exactly what does happen in compressed-air motors, and if the compressed air contains much moisture, the temperature may fall so low that this moisture is frozen and collects as a frost in the exhaust pipe. Frost may even collect to such an extent as to clog the exhaust pipe and stop the motor. The methods used to overcome this obstacle will be discussed later in detail.

The principal characteristics of air to be considered in discussing its mechanical uses are: pressure, temperature, volume, weight and humidity.

The relations existing between the temperature and humidity have been considered, but before considering the other characteristics mentioned, it is necessary to state clearly certain fundamental definitions.

CHAPTER II

FUNDAMENTAL DEFINITIONS

Work.—Work is a force overcoming resistance, and is measured in foot-pounds. A force of 10 lb. exerted for a distance of 4 ft. represents 10×4 or 40 ft.-lb. of work, or a 100-lb. weight lifted 3 ft. represents 300 ft.-lb. of work, etc.

Energy.—Energy is the ability to do work and may be measured in the same units. Energy may exist in a number of forms, for example: a water-fall, heat, light, electricity, the wind, etc. The source of all energy is the sun, but unfortunately this energy, as it reaches the earth, is not in the most suitable form for all of the work of the world. It is the province of the engineer to change available energy into the desired form with as few losses and as few changes as possible. Most of the energy required in commercial enterprises is supplied by coal, but the burning of coal represents the use of energy from the sun which reached the earth ages ago. It is only a question of time when other sources of energy than coal will have to be provided in greater abundance than at present and the attention of scientific investigators is being called to the importance of a more direct method of getting energy from the sun and of using other available forms of energy with fewer changes than are now necessary.

Heat.—Heat may be defined as a form of energy, without at this time going into any discussion regarding its characteristics or effects.

Power.—Power is defined as the rate of doing work. The engineers' unit being the horse-power, or 33,000 ft.-lb. of work per minute.

Temperature.—Temperature is an indication of the direction in which heat will flow if it has an opportunity to do so. That is, heat will naturally flow from a hot to a cold body. Temperature does not represent the heat energy that a substance contains.

Absolute Temperature.—Temperature in engineering work is

usually measured on the Fahrenheit thermometer in which the freezing-point of water at atmospheric pressure is 32° and the boiling-point is 212° . As the temperature falls, the vibration of the molecules becomes less rapid and the energy contained in any substance decreases. That point at which the vibration of the molecules ceases is called absolute zero. From a study of the property of gases, it is evident that this point is about 460° below the zero-point of the Fahrenheit scale. The absolute temperature, then, is the sum of the temperature Fahrenheit and 460° .

B.t.u.—Amounts of heat are measured in British thermal units. A B.t.u. is the amount of heat required to raise the temperature of 1 lb. of water from 63° to 64° F. The mechanical equivalent of this is about 778 ft.-lb. This is usually represented by the letter J , and its reciprocal, or $\frac{1}{778}$, by A .

Effects of Heat.—If heat is applied to a substance, many of its characteristics may change. Its pressure may change, temperature may change; its volume, conductivity, elasticity, etc., may also be affected by the application of heat. However, all these effects may be classified into two groups: internal changes and external changes. This may be represented by an equation as follows: Heat applied = internal energy changes + external energy changes.

The internal changes may be represented in part by changes of temperature which mean an increase in the velocity with which the molecules vibrate back and forth. This energy expressed in heat units may be represented by S . If a substance is of such a nature that expansion takes place when heat is applied, then the molecules must be separated farther apart against whatever mutual attraction exists between them. This also represents an internal application of energy and can be represented by the letter L .

If external work is done, as in the expansion of any substance at constant pressure, this work can be measured by the product of the pressure in pounds per square foot and the change in volume measured in cubic feet. The product in foot-pounds can be represented by the letter W , and its heat equivalent as AW .

If the heat supplied in B.t.u. is represented by Q , the equation $Q = S + L + AW$, in which each term is measured in B.t.u. may be considered as a fundamental energy equation.

Energy in Air.—Air may be treated as a perfect gas or as a substance in which there is no mutual attraction existing between the molecules. In this case $L = 0$, and the fundamental equation

when applied to air becomes $Q=S+AW$. That is, if heat is applied to air the effect of that heat (Q) will be either to increase its temperature (S) or to cause the air to expand and do work (AW), or both. However, of the heat energy given to the air, the only portion that can be stored up in the air itself (internal energy) will be that portion which is used in increasing the temperature of the air. In other words, *the internal energy of air depends upon its temperature alone.*

This statement is very important and should be thoroughly appreciated by the engineer working with compressed air.

At first thought, it does not seem possible that there is no more energy in the air (internal or intrinsic energy) if at atmospheric pressure than if the air is compressed and at the same temperature as the atmosphere. This, however, is the case, as shown by the above equations.

Although 1 lb. weight of air at a pressure of 1,000 lb. per square inch at the temperature of the atmosphere has no more internal energy than 1 lb. of air at atmospheric pressure and temperature, still the energy contained in the air under pressure is available for use, while that under atmospheric pressure is not, for in the first case the compressed air may expand, suffer a loss of pressure and also of temperature, cool to a point below the temperature of the atmosphere, and in that way give up a portion of its internal energy. The greater the fall of pressure during expansion, the greater the fall of temperature, and hence the greater the amount of internal energy available for use.

Some engineers are under the impression that the energy used in compressing air is actually stored up in the air. This, however, is far from true, the internal energy in compressed air depends on its temperature alone, and that part of this internal energy that may be available for use will depend upon the fall of pressure and hence of *temperature* that is permissible.

Specific Heat.—The specific heat of a substance in English units is the amount of heat required to increase the temperature of 1 lb. of the substance by one degree, and is usually represented by C .

Specific Heat at Constant Pressure.—The specific heat at constant pressure (C_p) is the amount of heat required to increase the temperature of 1 lb. of the substance one degree F. the pressure remaining constant.

Specific Heat at Constant Volume.—The specific heat at constant volume C_v is the amount of heat required to increase the tempera-

ture of 1 lb. of the substance one degree, the volume remaining constant.

As external work is done during a change at constant pressure, it is quite clear that the former specific heat is greater than the latter, that is, $C_p > C_v$.

Real Specific Heat.—The *real* specific heat of a substance is the amount of heat required to merely increase the temperature of 1 lb. of the substance, one degree F. that is, this excludes any energy that may be used in doing external or other work.

Apparent Specific Heat.—The *apparent* specific heat is the amount of heat required to increase the temperature of 1 lb. of the substance one degree F. including heat used in doing external or other work at the same time. This is, therefore, usually greater than the real specific heat. From the fundamental equation $Q=S+AW$, it is apparent that, if all the heat applied is to be used in raising temperature, $AW=0$ and $Q=S$. This condition can only exist if there is no change in volume.

For a perfect gas, and hence for air, the real specific heat is equal to the specific heat at constant volume, that is, C_v .

These specific heats are measured in heat units, but may be expressed in foot-pounds by multiplying by the mechanical equivalent of a heat unit or 778 ft.-lb., or J . When this is done, the specific heat is represented by K , that is,

$$JC_v = K_v \text{ and } JC_p = K_p.$$

TABLE III.— C_p FOR AIR AT VARIOUS PRESSURES AND TEMPERATURES

Temperatures Fahrenheit	Pressures in atmospheres and pounds per square inch absolute					
	1 14.7 lb.	10 147 lb.	20 294 lb.	40 588 lb.	70 1,029 lb.	100 1,470 lb.
212°	0.2372	0.2389	0.2408	0.2446	0.2512	0.2583
32°	0.2375	0.2419	0.2465	0.2512	0.2773	0.2986
-58°	0.2380	0.2455	0.2572	0.2785	0.3319	0.4124
-148°	0.2389	0.2585	0.2844	0.3697	0.3461
-238°	0.2424	0.3105	0.5048
-274°	0.2467	0.4147

The specific heat of air at constant pressure, (C_p) is usually taken as 0.2375 B.t.u., and the specific heat at constant volume, (C_v) as 0.1689 B.t.u. The ratio of these two specific heats, $\frac{C_p}{C_v}$ or 1.405, is frequently used as shown later in compressed-air calculations.

As a matter of fact, the specific heat of air at constant pressure is not the same under all conditions, as it increases with increasing pressures or decreasing temperatures, as shown in Table III given by Prof. Linde.

CHAPTER III

CHARACTERISTIC AND ENERGY EQUATIONS FOR AIR

The principal characteristics of air to be studied are its pressure, volume and temperature. Pressure may be measured in pounds per square inch or pounds per square foot, and in the equations that follow, absolute pressure is used. This is the sum of the pressure of the atmosphere and the pressure shown by the gage. When measured in pounds per square inch, the pressure will be indicated by p . When measured in pounds per square foot, it will be indicated by P . Volumes are measured in cubic inches or cubic feet, usually the latter. If the volume of a 1 lb. weight in cubic feet is considered, it will be represented by v . If the total volume of any weight in cubic feet is considered, it will be represented by V . Temperature may be measured on the Fahrenheit scale, and when so done is indicated by t . If absolute temperature is considered, it will be represented by T . $T = t + 460$.

Boyle's Law.—Boyle's law for perfect gases, which was determined by experiment, states that the product of the pressure and volume of a perfect gas is a constant if the temperature is constant. That is, $p_1v_1 = p_2v_2 = p_3v_3$, etc., if the temperature is constant, or $P_1V_1 = P_2V_2$, etc., or $P_1v_1 = P_2v_2$.

Law of Charles.—The law of Charles states that the volume varies inversely as the temperature, if the pressure is kept constant. Or $\frac{v_1}{T_1} = \frac{v_2}{T_2}$, etc., if the pressure is constant.

Characteristic Equation for Perfect Gases.—Combining these two equations, which were determined by experiment, $\frac{p_1v_1}{T_1} = \frac{p_2v_2}{T_2}$, or $\frac{P_1v_1}{T_1} = \frac{P_2v_2}{T_2}$, a constant is obtained. This constant will be indicated as R and the above equation as $P_1v_1 = RT_1$.

Numerical Value of R.—The value of this constant ($R = \frac{P_1v_1}{T_1}$) will vary with the gas considered. For example: As 1 lb. weight of oxygen at 32° F. and 14.7 lb. absolute pressure occupies 12.21 cu. ft., the

value of this constant for oxygen will be $\frac{14.7 \times 144 \times 12.21}{460 + 32} = 52.4$.

In the same way, as the volume of 1 lb. weight of air at this temperature and pressure is 12.39 cu. ft., the value of this constant for air is $\frac{14.7 \times 144 \times 12.39}{460 + 32} = 53.3$.

Weight of Air.—In the equation, $\frac{P_1 v_1}{T_1} = \frac{P_2 v_2}{T_2} = 53.3$, for 1 lb. of air, this may be multiplied by the number of pounds of air, giving the equation $\frac{P_1 V_1}{T_1} = \frac{P_2 V_2}{T_2} = w 53.3$, in which w represents the number of pounds of air. This equation is of great assistance in determining the weight of air in a certain receiver. For example: If a receiver 3 ft. in diameter by 10 ft. high, and having, therefore, a volume of 70.68 cu. ft., contains air at a temperature of 70° F. and a gauge pressure of 143.3 lb., or 158 lb. absolute, the weight of air contained in the receiver if the pressure of the atmosphere is 14.7 lb. per square inch will be $\frac{P_1 V_1}{53.3 T_1} = \frac{158 \times 144 \times 70.68}{53.3 \times (460 + 70)} = 56.9$ lb.

Relation between Specific Heats.—If 1 lb. of air contained in a vertical cylinder having a weighted piston above is heated, the temperature of the air will increase and, as the pressure is kept constant, the heat absorbed, may be expressed as the product of the amount of heat required to cause a change of one deg. F. and the actual change in temperature measured in degrees F. or as $C_p(T_2 - T_1)$ in B.t.u., or $K_p(T_2 - T_1)$, if expressed in mechanical units; where T_1 and T_2 are the initial and final temperatures respectively.

S , the energy required to cause the increase in temperature alone, is $C_v(T_2 - T_1)$ in heat units; $K_v(T_2 - T_1)$, if expressed in foot-pounds.

W , the external work, must be $P_1(v_2 - v_1)$, where P_1 represents the pressure on the piston in pounds per square foot; v_1 and v_2 the initial and final volumes of the air respectively in cubic feet, but as $Pv = RT$ this may be expressed as $R(T_2 - T_1)$; that is, the heat energy applied, or $778Q = K_v(T_2 - T_1) + R(T_2 - T_1)$, in foot-pounds. But the heat energy applied may also be represented by the expression, $K_p(T_2 - T_1)$, hence:

$$\begin{aligned} K_p(T_2 - T_1) &= K_v(T_2 - T_1) + R(T_2 - T_1) \\ K_p &= K_v + R, \text{ or } R = K_p - K_v = 778(C_p - C_v) = \\ &778(0.2375 - 0.1689) = 53.3 \end{aligned}$$

If expansion of air takes place in a perfectly non-conducting

cylinder, Q of the equation $Q=S+AW$ must equal 0 , and hence $W = -\frac{S}{A}$, or $W = -778S$; that is, during an adiabatic expansion of air, as it is called, the temperature falls and the amount of energy used in doing work during the expansion will be given by the expression $K_v(T_1-T_2)$ in foot-pounds.

As no heat energy is given to the substance nor taken from it during this change, all the work that is done must be done at the expense of the internal energy.

The principal relations known to exist between K_p and K_v for air are as follows:

$$K_p > K_v \quad \frac{K_p}{K_v} = 1.405$$

$$K_p = K_v + R = K_v + 53.3$$

$$K_p - K_v = 53.3$$

Work of Isothermal Change.—From the characteristic equation for air, it is evident that if the temperature is a constant, $PV =$

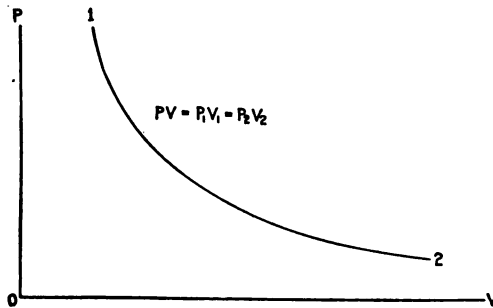

FIG. 5.—Isothermal change of air.

constant, or $P_1V_1 = P_2V_2 = P_3V_3$, etc. That is, if a certain volume of air is compressed to one-half its original volume isothermally, its pressure will be doubled, while if its volume is reduced to one-fourth its original volume, its pressure will be quadrupled, etc. This relation follows the path shown by the isothermal curve of the chart, Fig. 5, the equation being that of an equilateral hyperbola.

In order to find the work done during an isothermal compression, it is necessary to find the area under the compression curve drawn on a PV diagram or plane, this area representing the work done

expressed in foot-pounds. The fundamental expression for any area on a pressure—volume diagram is given by the expression,

$$\text{Area} = \text{work} = \int P dV$$

with the isothermal curve $PV = P_1V_1$, hence $P = \frac{P_1V_1}{V}$, and

$$W = \int_{V_1}^{V_2} P_1V_1 \frac{dV}{V} = P_1V_1 \int_{V_1}^{V_2} \frac{dV}{V}$$

hence,
$$W = P_1V_1 \log_e \frac{V_2}{V_1}$$

where P_1 represents the maximum pressure in pounds per square foot and V_1 the minimum total volume of the compressed air in cubic feet, V_2 the total volume in cubic feet occupied by the air before compression.

This also represents the work done by any number of pounds of air expanding at constant temperature from an initial volume of V_1 cu. ft. to a final volume of V_2 cu. ft. If 1 lb. of air expands in this way the work done will be represented by the equation $P_1v_1 \log_e \frac{v_2}{v_1}$, or as $P_1v_1 = RT_1$, this may be written $RT_1 \log_e \frac{v_2}{v_1}$.

As the relation $P_1v_1 = P_2v_2$ applies to this isothermal change, the equation may also be written $P_1v_1 \log_e \frac{P_1}{P_2}$ or $RT_1 \log_e \frac{P_1}{P_2}$.

To illustrate the application of this formula, suppose it is required to find the work done as 1 lb. of air expands at constant temperature of 120° F. from a pressure of 150 lb. per square inch absolute to 30 lb. per square inch absolute the work done will be:

$$53.3 \times (120 + 460) \log_e \frac{150 \times 144}{30 \times 144}$$

It is evident that the ratios of pressures in pounds per square inch is the same as the ratios of pressures in pounds per square foot.

$$53.3 \times 580 \times \log_e 5 = 53.3 \times 580 \times 1.6094, \text{ or } 49,800 \text{ ft.-lb.}$$

A table of logarithms to the base e , or hyperbolic or Napierian logarithms as they are called, is given in Appendix B. This is for numbers from 1 to 10. If it is desired to obtain other logarithms as for the number 0.12, this is equal to the \log_e of 1.2 minus the \log_e

of 10, or the \log_e of $\frac{1.2}{10}$. In the same way the \log_e of 25 is the same as the \log_e of (2.5×10) , or the \log_e of 10 plus the \log_e of 2.5.

Work of Exponential Change.—When the equation of the compression line is unknown, it may be represented by the equation $PV^n = a$ constant, where n is the unknown exponent (Fig. 6).

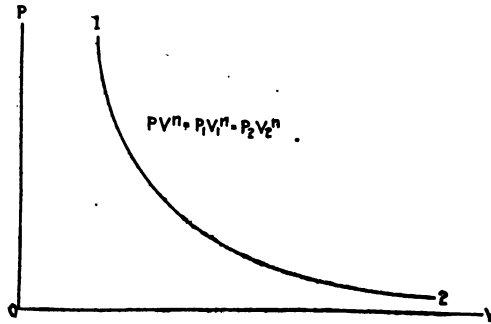

FIG. 6.—Exponential change of air.

$PV^n = P_1V_1^n$ and $P = \frac{P_1V_1^n}{V^n}$. Substituting in the formula for work

$$W = \int PdV; W = \int_{V_1}^{V_2} P_1V_1^n \frac{dV}{V^n} = P_1V_1^n \int_{V_1}^{V_2} \frac{dV}{V^n} = P_1V_1^n \int_{V_1}^{V_2} V^{-n} dV$$

$$W = \frac{P_1V_1^n(V_2^{1-n} - V_1^{1-n})}{1-n}, \text{ but as } P_1V_1^n = P_2V_2^n, W =$$

$$\frac{P_2V_2 - P_1V_1}{1-n} = \frac{P_1V_1 - P_2V_2}{n-1}$$

P_1 represents the maximum pressure and P_2 the minimum pressure in pounds per square foot, and V_1 the minimum total volume of the compressed air in cubic feet and V_2 its volume in cubic feet before compression.

The above expression for work also represents the number of foot-pounds of work that will be done by any number of pounds of air expanding according to a change of pressure and volume represented by $P_1V_1^n = P_2V_2^n$.

If 1 lb. of air expands in this way the work done will be represented by the equation

$$W = \frac{P_1v_1 - P_2v_2}{n-1} = \frac{R(T_1 - T_2)}{n-1}. \text{ As } P_1v_1^n = P_2v_2^n, P_2v_2 = P_1v_1 \left(\frac{v_1}{v_2}\right)^{n-1}$$

From this it is evident that the equation may also be written:

$$\frac{P_1 v_1}{n-1} \left[1 - \left(\frac{v_1}{v_2} \right)^{n-1} \right], \text{ or as } \frac{P_1 V_1}{n-1} \left[1 - \left(\frac{P_2}{P_1} \right)^{\frac{n-1}{n}} \right]$$

As an illustration suppose it is required to find the work done as 1 lb. of air expands according to the equation $P_1 v_1^{1.4} = P_2 v_2^{1.4}$ from an initial pressure of 180 lb. per square inch absolute and a volume of 1.2 cu. ft. to a final pressure of 15 lb. per square inch absolute, the work done will be

$$\frac{180 \times 144 \times 1.2}{1.4-1} \left[1 - \left(\frac{15}{180} \right)^{\frac{1.4-1}{1.4}} \right] = \frac{180 \times 144 \times 1.2}{1.4-1} \left[1 - 0.083^{0.285} \right]$$

$$= 77,760 [1 - 0.492] = 77,760 \times 0.508 = 39,502 \text{ ft.-lb.}$$

Work of Adiabatic Change.—If a change takes place in a cylinder surrounded by non-conducting walls preventing energy in the form of heat from entering or leaving the cylinder, this change is called adiabatic.

During an adiabatic expansion of 1 lb. of air, the work done may be represented by the equation $K_v(T_1 - T_2)$, as for such a change $AW = -S$ or $W = -778S$, and $S = C_v(T_2 - T_1)$.

As $P_1 v_1 = RT_1$ and $P_2 v_2 = RT_2$

$$K_v(T_1 - T_2) = \frac{K_v(P_1 v_1 - P_2 v_2)}{R}$$

but $R = K_p - K_v$

$$\text{then } K_v(T_1 - T_2) = \frac{K_v(P_1 v_1 - P_2 v_2)}{K_p - K_v} = \frac{P_1 v_1 - P_2 v_2}{\frac{K_p}{K_v} - 1}$$

This expression must equal the expression for work under an exponential curve, viz.:

$$\frac{P_1 v_1 - P_2 v_2}{n-1}$$

hence for an adiabatic change of 1 lb. of air, the exponent in the equation $P_1 v_1^n = P_2 v_2^n$ must equal $\frac{K_p}{K_v}$, that is,

$$P_1 v_1^{\frac{K_p}{K_v}} = P_2 v_2^{\frac{K_p}{K_v}} \text{ and for } w \text{ lb.}$$

$$P_1 V_1^{\frac{K_p}{K_v}} = P_2 V_2^{\frac{K_p}{K_v}} = P_3 V_3^{1.406}$$

Relations Between P, v and T for Adiabatic and Exponential Change.—This shows the relations existing between P and v for an adiabatic change. In order to find the relations between P and T or v and T for such a change, it is necessary to turn to the characteristic equation $Pv = RT$, or

$$\frac{P_1 v_1}{T_1} = \frac{P_2 v_2}{T_2} = \frac{P_3 v_3}{T_3}$$

then
$$\frac{P_1}{P_2} = \frac{v_2 T_1}{v_1 T_2}$$

But as
$$P_1 v_1^{1.405} = P_2 v_2^{1.405}$$

then
$$\frac{P_1}{P_2} = \left(\frac{v_2}{v_1}\right)^{1.405}$$

Equating
$$\left(\frac{v_2}{v_1}\right)^{1.405} = \frac{v_2 T_1}{v_1 T_2} \text{ and } \left(\frac{v_2}{v_1}\right)^{0.405} = \frac{T_1}{T_2}$$

As
$$\frac{P_1}{P_2} = \left(\frac{v_2}{v_1}\right)^{1.405}$$

then
$$\left(\frac{P_1}{P_2}\right)^{\frac{0.405}{1.405}} = \left(\frac{v_2}{v_1}\right)^{0.405}, \text{ hence } \left(\frac{P_1}{P_2}\right)^{\frac{0.405}{1.405}} = \frac{T_1}{T_2}$$

or,
$$\left(\frac{P_1}{P_2}\right)^{0.2882} = \frac{T_1}{T_2} = \left(\frac{v_2}{v_1}\right)^{0.405}$$

In the same way for changes represented by the exponential equation $P_1 v_1^n = P_2 v_2^n$.

$$\left(\frac{v_2}{v_1}\right)^{n-1} = \frac{T_1}{T_2} \text{ and } \left(\frac{P_1}{P_2}\right)^{\frac{n-1}{n}} = \frac{T_1}{T_2}$$

Computation of Intrinsic Energy.—These equations enable calculations to be made of temperature changes during adiabatic compression and are used in calculating the heat curves of the chart, Fig. 11.

During an adiabatic expansion of air all the work that is done must be done at the expense of the intrinsic energy. This can be shown from the equation $Q = S + AW$, which becomes $0 = S + AW$ for an adiabatic change, for from the definition Q must equal zero. This being true, $W = \frac{-S}{A}$, or a measure of the work done would give also

a measure of the change in intrinsic energy. That is, if the initial pressure and volume of w lb. of air is known, the equation

$$\frac{P_1V_1 - P_2V_2}{n - 1} = \frac{P_1V_1 - P_2V_2}{1.405 - 1} = \frac{P_1V_1 - P_2V_2}{0.405}$$

will be a measure of the intrinsic energy available. In this equation P_1 and P_2 represent respectively the initial and final pressures in pounds per square foot.

If v_1 and v_2 be used representing the specific volumes, that is, the volumes occupied by 1 lb. weight, then the equation given represents the work done and the change of internal energy of 1 lb. weight only; but if V_1 and V_2 be used representing the initial and final volumes occupied by all the air concerned in the expansion, the equation $\frac{P_1V_1 - P_2V_2}{1.405 - 1}$ will represent the entire amount of intrinsic energy available for use in expansion of w lb. from pressure P_1 and volume V_1 to a pressure P_2 and volume V_2 .

If P_1 and V_1 are known as well as P_2 , the final pressure, V_2 may be calculated if the equation of the expansion line is known. This equation will be

$$P_1V_1^{1.405} = P_2V_2^{1.405}$$

the equation for an adiabatic expansion.

If the expansion is not adiabatic, the equation $\frac{P_1V_1 - P_2V_2}{0.405}$ cannot be used for calculating a change of internal energy. In order to obtain the amount of internal energy contained in air it is merely necessary to assume an adiabatic expansion to infinity. The area under such an expansion curve is finite and amounts to $\frac{P_1V_1}{0.405}$. For example, the internal energy contained in 1 lb. of air at atmospheric pressure and 32° F., with a volume of 12.39 cu. ft. is $\frac{P_1v_1}{0.405}$ or $\frac{RT_1}{0.405}$, which is

$$\frac{14.7 \times 144 \times 12.39}{0.405}, \text{ or } \frac{53.2 \times 493}{0.405}, \text{ or } 64,730 \text{ ft.-lb.}$$

It is, of course, impossible to obtain this amount of energy from a pound of air, as it is impossible to secure its complete expansion to absolute zero of pressure.

CHAPTER IV

GRAPHICAL DIAGRAMS

Construction of Isothermal Curves.—It is frequently necessary or desirable to construct graphically compression curves representing isothermal and adiabatic changes of air. A method of constructing the isothermal curve is shown in Fig. 7, in which *O* represents the intersection of the coordinates of a pressure-volume plane.

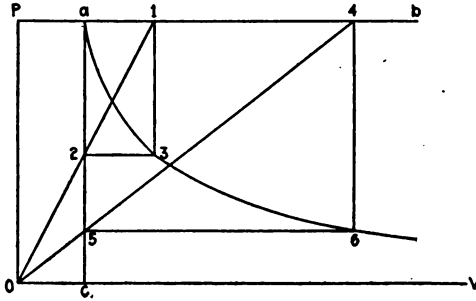

FIG. 7.—Graphical construction of equilateral hyperbola.

represents the intersection of the coordinates of a pressure-volume plane. If an isothermal line is to be drawn through point *a*, construct horizontal line *a-b* and vertical line *a-c*, as shown, then draw any diagonal line as *o-1* and complete the rectangle *a-1-2-3*; 3 is a point on the required curve. In the same way, other diagonals, as *o-4*, may be drawn, and the rectangle *a-4-5-6* constructed, giving point 6 as another point on the required curve, etc.

Another method of constructing this curve is shown in Fig. 8. Assume that it is required to draw the isothermal line for air through point *a*. A diagonal line, as *1-2*, may be drawn through this point and the distance *2-b* made equal to *1-a*; *b* is a point on the required curve. In the same way line *3-4* may be drawn through *b* and the distance *4-c* made equal to the distance *3-b*, giving another point *c* on the required curve, etc.

In the equation $PV^n = P_1V_1^n = P_2V_2^n$, etc., the value of the exponent *n* may be found, if the values of *P* and *V* for any two points

are known, by taking logarithms of both sides of the equation, $P_1V_1^n = P_2V_2^n$

$\log P_1 + n \times \log V_1 = \log P_2 + n \times \log V_2$, and from this

$$n = \frac{\log P_1 - \log P_2}{\log V_2 - \log V_1}$$

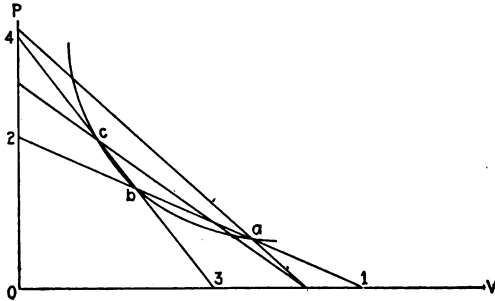

FIG. 8.—Graphical construction of equilateral hyperbola.

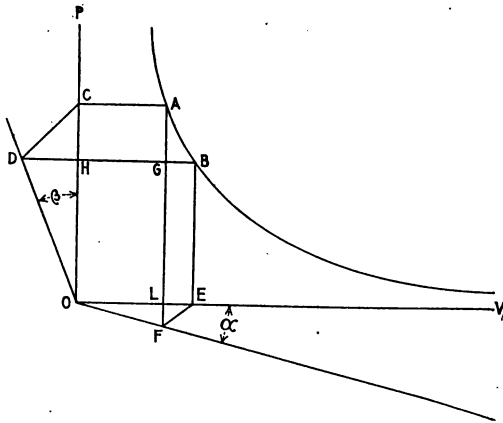

FIG. 9.—Graphical construction of exponential curve.

Figure 9 represents graphically a curve whose equation is $P_1V_1^n = P_2V_2^n$ in which the numerical value of n is 1.405. Curves of this type may be classed as exponential or logarithmic curves. A simple method (Brauer's) of constructing such curves graphically is given below, together with a development of the equations used.

Construction of Exponential Curve.—Brauer's method of constructing an exponential curve may be illustrated by assuming any two points, as A and B , Fig. 9, of such a curve and drawing lines through both points perpendicular to both axes. Through C and E

draw lines making an angle of 45 degrees the with axes. *D* represents the intersection of *CD* with *BH* produced, and *F* the intersection of *EF* with *AL* produced.

Connecting points *D* and *F* with *O* will give the two angles *DOP* or β and *FOV* or α . In order to determine the relations between these angles, the following demonstration is given:

$$\begin{aligned}
 P_A &= P_B + AG = P_B + CH = P_B + DH \\
 DH &= P_B \tan \beta \\
 P_A &= P_B(1 + \tan \beta) & (1) \\
 V_B &= V_A + GB = V_A + LE = V_A + LF \\
 LF &= V_A \tan \alpha \\
 V_B &= V_A(1 + \tan \alpha) \\
 V_B^n &= V_A^n(1 + \tan \alpha)^n & (2)
 \end{aligned}$$

Multiplying equations (1) and (2)

$$P_A V_A^n (1 + \tan \alpha)^n = P_B V_B^n (1 + \tan \beta)$$

but, $P_A V_A^n = P_B V_B^n$

$$(1 + \tan \alpha)^n = 1 + \tan \beta$$

$$\tan \beta = (1 + \tan \alpha)^n - 1$$

This shows the relation between the angles β and α in terms of the exponent *n*.

For convenience, it is customary to make tangent of angle $\alpha = 0.25$. $\tan \beta$ has been computed for various values of *n* as follows:

<i>n</i>	Tang. β
0.7	0.169
0.8	0.195
0.9	0.223
1.0	0.25
1.0646	0.268
1.135	0.288
1.25	0.322
1.333	0.347
1.37	0.358
1.41	0.37

If, for example, a curve is to be drawn through any point, as *A* following the equation $P_1 V_1^{1.25} = P_2 V_2^{1.25}$, lay off angle *VOF*, or α , with a tangent equal to 0.25 and angle *POD*, or β , with a tangent of 0.322; then draw *AC* and *AL* through *A*, and construct lines *CD* and *FE*, making angles *CDH* and *FEL* equal to 45 degrees, the intersection of the horizontal line from *D* and the vertical line from *E* will give point *B* as one of the required points of the curve. In the same way, other points of the required curve may be obtained.

Heat added or taken away for Isothermal Change.—The fundamental equation showing the effects of applying heat to air, $Q=S+AW$, enables a determination of Q , the heat to be applied in the case of expansion, or the heat to be taken away in the case of compression in order to cause the expansion or compression line to follow a certain exponential curve. If this required expansion or compression curve is to be isothermal, $S=O$ and $Q=AW$, that is, the heat to be applied to secure isothermal expansion must equal the heat equivalent of the

work done during the expansion, or $\frac{P_1V_1 \log_e \frac{V_2}{V_1}}{778}$ heat units, and in the same way the heat to be taken away, in order to secure isothermal compression, must equal the heat equivalent of the work done during the compression.

Heat Added or taken away for Exponential Change.—Frequently it is desired to secure a compression or expansion curve between the

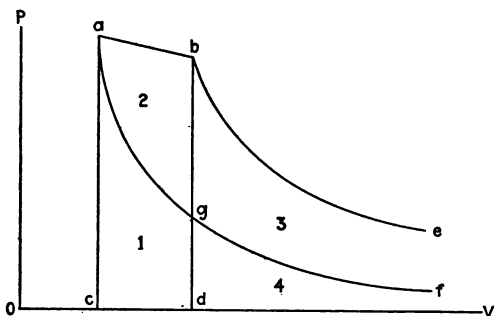

FIG. 10.—Graphical measurement of change of heat energy.

isothermal and adiabatic, following the equation $P_aV_a^n=P_bV_b^n$, as shown in Fig. 10, in which n is less than 1.405. In this case $Q=S+AW$. It has been pointed out that the mechanical equivalent of the internal energy possessed by air is represented by the area under an adiabatic curve continued to infinity and in Fig. 10 af represents such a curve through point a and be such a curve through point b . W , or the external work done between a and b , is represented by the area $abcd$, or $1+2$. $S \times 778$, or the internal energy for point a by the area $1+4$, and $S \times 778$ for point b by the area $3+4$. The change of internal energy in going from a to b in the case of expansion will be area $(3+4) - \text{area } (1+4)$, or $3-1$, and as $W=1+2$, the mechanical equivalent of Q must equal $S \times 778 + W$, or

(3-1)+(1+2), or (3+2). That is, the mechanical equivalent of the heat energy to be added during expansion from *a* to *b*, or taken away during compression from *b* to *a*, in order to follow a certain curve on the *PV* diagram, will be the area bounded by the curve *ab* and two adiabatics from the ends of the curve to infinity,

$$\text{or, } \frac{P_a V_a - P_b V_b}{n-1} - \frac{P_a V_a^{1.405}}{0.405} + \frac{P_b V_b^{1.405}}{0.405}$$

Difference between Isothermal and Adiabatic Compression.—
The difference between adiabatic and isothermal compression is

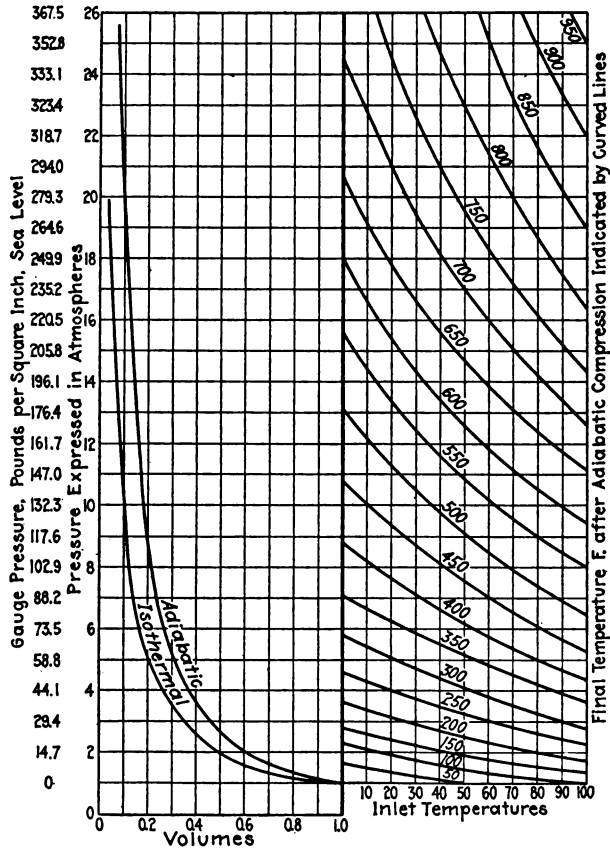

FIG. 11.—Temperature change due to adiabatic compression.

illustrated by the two curves on the *PV* plane at the left of Fig. 11, which shows that while an isothermal compression of free air to half its original volume will raise its pressure to 2 atmospheres, or 14.7

lb. gauge at sea-level, the same reduction of volume adiabatically will raise its pressure to 2.82 atmospheres, or 26.75 lb. gage. If the reduction of volume is to 0.2 of the original volume, the pressure for isothermal compression will be 5 atmospheres or 58.8 lb. gage at sea-level, and for adiabatic compression 8.88 atmospheres or 115.83 lb. gage.

Temperatures due to Adiabatic Compression.—Adiabatic compression is always accompanied by an increase of temperature following the equation $\frac{T_1}{T_2} = \left(\frac{V_2}{V_1}\right)^{0.405}$, or $\frac{T_1}{T_2} = \left(\frac{P_1}{P_2}\right)^{0.2882}$. This shows the ratio of the final absolute temperature to the initial temperature.

The right-hand part of Fig. 11 shows the resulting temperature Fahrenheit for adiabatic compression with initial temperatures varying from 0° to 100° F. From this it is evident that adiabatic compression to 0.2, the original volume and consequently 8.8 atmospheres, will approximate a final temperature 510° F. if the initial temperature is 60° F.

Very high temperatures are to be avoided in compressing air as an explosion may result if the temperature is sufficient to ignite the volatile matter contained in the lubricating oils used. In addition to this, the energy represented by the high temperature will soon be dissipated by radiation. Isothermal compression requires removal of heat energy during compression, and this cannot be accomplished satisfactorily with piston or fan compressors operating at modern speeds. Because of these conditions, high compression is secured in modern compressors by compressing by stages and cooling the air between stages. Compression in single-stage compressors is usually accompanied by such cooling as can be secured by water-jackets or other means, but with the speeds required the usual effect is to secure a compression curve with an exponent n varying between 1.25 and 1.33.

Work done by a Compressor.—The work done in a machine, which draws in air, compresses it, and then discharges the compressed air, can be calculated, if the suction and discharge pressures are known and the character or exponent of the compression curve is given.

Exponential Compression.—Let Fig. 12 represent such a series of changes for any compressor, in which the effect of clearance is disregarded. In this diagram, which is somewhat similar to the indicator card from a piston compressing cylinder, $d-a$ represents the intake of air at a pressure of p_2 lb. per square inch, $a-b$ represents the compression of this air from p_2 to p_1 lb. per square inch following

the compression curve $p_1V_1^n = p_2V_2^n$ and $b-c$ represents the discharged of the compressed air at a pressure p_1 lb. per square inch.

The area enclosed by the lines $d-a-b-c-d$ will represent the work done if V represents the volume in cubic feet and if p , representing the pressures in pounds per square inch, be multiplied by 144 to give pressures in pounds per square foot.

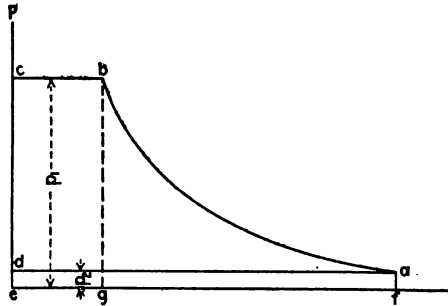

FIG. 12.—Work diagram of air compressor.

The required area will be area $a-b-g-f$ plus area $b-c-e-g$ minus area $a-d-e-f$,

$$\text{or } 144 \frac{p_b V_b - p_a V_a}{n-1} + 144 p_2 V_b - 144 p_1 V_a$$

$$\text{or } 144(p_b V_b - p_a V_a) \left(\frac{1}{n-1} + 1 \right), \text{ or } \frac{n}{n-1} 144(p_b V_b - p_a V_a)$$

V_a is usually known in compressed-air calculations, but V_b is not known directly, but as $p_a V_a^n = p_b V_b^n$ this equation may be simplified, for $p_b V_b = p_a V_a \left(\frac{V_a}{V_b} \right)^{n-1}$, or $p_b V_b = p_a V_a \left(\frac{p_b}{p_a} \right)^{\frac{n-1}{n}}$, and the expression may be written:

$$\frac{n}{n-1} 144 p_a V_a \left[\left(\frac{p_b}{p_a} \right)^{\frac{n-1}{n}} - 1 \right]$$

Suppose, for example, it is desired to ascertain the work required to compress 2,500 cu. ft. of air from a suction of atmospheric pressure or 15 lb. absolute to a gauge pressure of 100 lb. per square inch, or 115 lb. absolute, following a compression line whose exponent is 1.3.

$$\text{This will require } \frac{1.3}{1.3-1} \times 144 \times 15 \times 2,500 \left[\left(\frac{115}{15} \right)^{\frac{1.3-1}{1.3}} - 1 \right]$$

$$\text{or, } 4.33 \times 144 \times 15 \times 2,500 \left[(7.66)^{0.23} - 1 \right]$$

$$\text{or, } 23,375,000 \times (1.59 - 1), \text{ or } 13,780,000 \text{ ft.-lb.}$$

If the compressor is to have this free-air capacity of 2,500 cu. ft. per minute, the horse-power required will be

$$\frac{13780000}{33000}, \text{ or } 418 \text{ h.p.}$$

Isothermal Compression.—If the compression line $a-b$ was an isothermal line, following the equation $p_a V_a = p_b V_b$, the expression for the area would be

$$144 \left[p_b V_b \log_e \frac{V_a}{V_b} + p_b V_b - p_a V_a \right], \text{ or } 144 p_b V_b \log_e \frac{V_a}{V_b}$$

or, $144 p_a V_a \log_e \frac{p_b}{p_a}$, or $144 \times 15 \times 2,500 \log_e \frac{115}{15}$

or, $5,400,000 \log_e 7.66 = 5,400,000 \times 2.036 = 11,000,000 \text{ ft.-lb.}$

If the compressor is to have this free-air capacity of 2,500 cu. ft. per minute, the horse-power required will be

$$\frac{11000000}{33000}, \text{ or } 333 \text{ h.p.}$$

These calculations show the advantage of having the exponent of the compression line as low as possible, or in other words keeping the temperature of the air during compression from rising. The advantages and methods of attempting this are discussed later.

The effect of valves, clearance and friction on the required horse-power is considered later in discussing piston compressors.

CHAPTER V

AIR AT PRESSURES BELOW THE ATMOSPHERE

A study of the properties of air, and of its applications would not be complete without reference to at least a few of the uses of air at pressures below the atmosphere.

For purposes of experiment and for laboratory uses, these low pressures are usually obtained by means of the familiar air pump.

Venturi Vacuum Pump.—Another method of securing these low pressures is by means of a very simple hydraulic air ejector or “venturi vacuum pump” as it is sometimes called.

This convenient instrument for quickly obtaining an approximate vacuum depends on the principle that a fluid passing at a high velocity through a converging and diverging nozzle in which the curves

conform to the shape of the “vena contracta” of a jet from an orifice, will produce an approximate vacuum at a point nearest its greatest contraction and if an air chamber is connected through an orifice at this point the air will be drawn into the jet and a very good vacuum formed in the chamber.

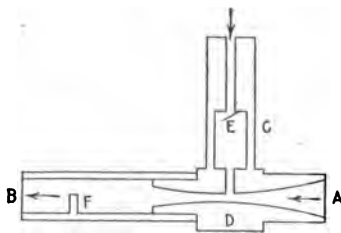

FIG. 13.—Hydraulic air pumps.

In the sketch shown in Fig. 13, tube *A* may be connected by a rubber hose to a faucet. The converging-diverging tube through which the water is forced is shown at *D*. Tube *C*, which is connected with the chamber from which the air is to be exhausted, has a check valve *E* and is connected to the smallest diameter of the nozzle. It has been found that better results are secured when a baffle *F* is introduced into the discharge pipe *B*, as shown.

Sprengle Air Pump.—For a more perfect vacuum than the air pump or the hydraulic air ejector the Sprengle mercurial air pump is used. This pump depends on the fact that if mercury is forced through an inverted U tube the mercury going over the bend will

exhaust the air from any chamber that is connected to the U tube at the top of the bend.

This pump is used for exhausting the air from incandescent lamp globes and remarkably low pressures are secured with it.

Measuring Vacuums.—Although the normal pressure of the atmosphere at sea-level is 14.7 lb. per square inch and pressures above that are designated in the same units, pressures below the atmosphere are not usually so designated but instead are expressed in inches of mercury. If a U tube at the sea-level is filled with mercury and one end connected with a perfect vacuum while the other is in contact with the atmosphere, the mercury will rise to a height of 29.92 in. above the level of the mercury in the leg that is exposed to the atmosphere (1 in. of mercury = 0.49 lb. per square inch). Consequently a vacuum gage indicating 20 would represent two-thirds of a perfect vacuum or a pressure of about 10 lb. below the atmosphere, that is, approximately 5 lb. absolute.

One of the most familiar uses of pressures below the atmosphere is in a condenser for steam engines in which the back pressure of the engine is reduced considerably below that of the atmosphere, thereby increasing the power of the engine.

Condenser Pumps.—Condenser pumps¹ are of two kinds: circulating pumps and air pumps, the circulating pumps being used to force the condensing water through the condenser and the air pumps for removing the condensed steam and air. In some types of condensers, the condensed steam is removed by gravity, as in the barometric type, and the air pump removes but air alone, being in this case called a "dry-air" pump to distinguish from the "wet-air" pump, which removes condensed steam as well as air.

Wheeler Combined Pump.—As a circulating pump usually lifts the water but a short distance, it is built as a tank pump, but should it be required to lift water through a long line of pipe, as a line to the top of a cooling tower, it must be made of heavier construction. Because of the large quantities of water which it handles, it is very frequently built of the centrifugal type. Fig. 14 shows a combined air and circulating pump of the Wheeler Condenser and Engineering Company. The steam cylinder is in the center, the air-pump cylinder at the left and the circulating-pump cylinder at the right.

The circulating pump forms one end support for the condenser. The water is discharged through *A* into one set of tubes and then

¹ Pumping Machinery, Greene.

it returns through *B* and the upper set of tubes to *C*, where it discharges. The air pump forms the other support for the shell. It takes the air and water from the condenser and discharges it through *D*. The suction space *F* is connected to *G*.

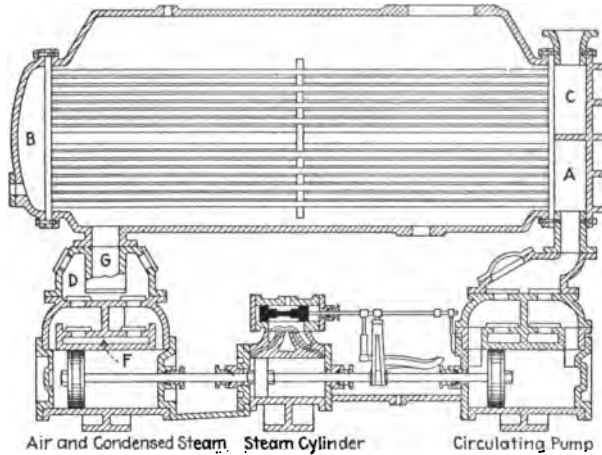

FIG. 14.—Wheeler condenser pump.

Size of Water and Air Pumps.—To find the size of the water and air ends of the pump, suppose that *W* pounds of steam per hour at a pressure *p* are to be condensed. If *r* is heat of vaporization of the steam, *x* its quality, *t_c*° the temperature of the condensed steam, and *q* the heat of the liquid, and if *G* pounds of water entering at *t_i*° F. and leaving at *t_o*° F. are to be used, *G* is given by the equation:

$$G = \frac{W(q + x.r - q_{tc})}{q_{t_o} - q_{t_i}} \text{ lbs. per hr.}$$

in which the subscripts of *q* indicate the temperature for which the heat of the liquid is obtained.

If the number of revolutions or double strokes *N* are assumed, the displacement of the water end will be

$$D_p = \frac{G}{120N \times 62.5} \text{ cubic feet.}$$

The air end of the pump is made in many cases of empirical design. Some authors give ratios of volume displaced by the pump per minute to the volume of the condensed steam or to the volume of the low-pressure cylinder of the engine which is discharging into the condenser. Several of these are mentioned.

RATIO OF AIR CYLINDER DISPLACEMENT TO LOW-PRESSURE CYLINDER

Single-acting vertical pump surface condenser.....	1 : 13
Single-acting vertical pump jet condenser.....	1 : 9
Double-acting horizontal pump surface condenser.....	1 : 15
Double-acting horizontal pump jet condenser.....	1 : 12
Double-acting horizontal pump-compound engine surface condenser.....	1 : 26
Single-acting horizontal pump-compound engine surface condenser.....	1 : 16

RATIO OF AIR CYLINDER DISPLACEMENT TO VOLUME OF CONDENSED STEAM.

Surface condenser.....	1 : 20
Jet condenser.....	1 : 40

This may be a satisfactory way, but it is better to estimate the volume from the air probably present. Water usually contains air to about one-fifteenth of its volume. This amount of air is at atmospheric pressure p_a and it must be cared for by the air pump at a reduced pressure. In addition to this there are small leaks in the pipe line which allow more air to enter. A small hole will destroy the vacuum of the air pump. To find the volume of air per minute the following formula will be used, allowing 100 per cent. for leakage.

$$V = \left(2 \times \frac{1}{15} \times \frac{W}{62.5}\right) \left(\frac{1}{60}\right) \frac{14.7 T_c}{(p - p_s) T_a} \text{ cubic feet per min.}$$

- p = absolute pressure in the condenser, pounds per square inch.
- p_s = vapor tension or absolute steam pressure corresponding to T_c .¹
- T_c = absolute temperature in condenser.
- T_a = absolute temperature of atmosphere.

This equation shows the importance of making p_s as much less than p as possible. The terms p and p_s do not differ much, and by taking the mixture of air and vapor on its way to the air pump, through as cold a passage as possible, the term p_s is made smaller and the denominator is increased, making V small. This is the reason for the great advantage in a counter current for condensers, and even in the condenser, shown in Fig. 14, the coldest water should enter directly over the air-pump inlet so as to cool the mixture going to the pump.

From the volume thus computed the displacement of the air pump is given by:

$$D_{ap} = \frac{V}{2N} \text{ cubic feet.}$$

¹ See discussion on Partial Pressures Appendix C.

Knowing the displacements of these pumps a stroke may be assumed, and from it the area determined.

$$A_p = \frac{D_p}{L}, \text{ sq. ft. for the water pump.}$$

$$A_{ap} = \frac{D_{ap}}{L}, \text{ sq. ft. for the air pump.}$$

Steam Cylinder Size.—The cards from the water end are shown in the lower part of Fig. 15, while those for the air end are shown above. The combination of these or the addition of them when

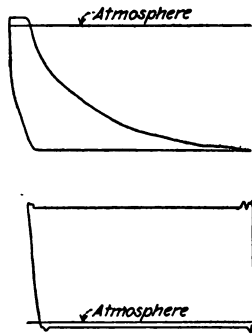

FIG. 15.—Indicator cards of condenser pump.

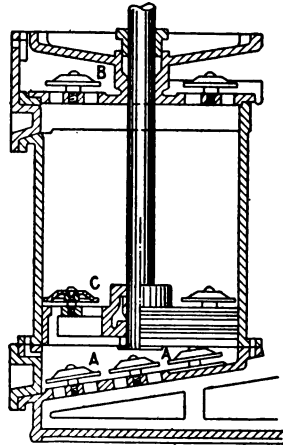

FIG. 16.—U. S. Navy pump cylinder.

reduced to the proper scale, on account of the difference in piston area, will give the total work, and from this the area of the steam cylinder may be calculated, if the mean effective pressure (M.E.P.)_s be found for a given boiler pressure. Allowing 33 per cent. for friction, which is made large to give certain driving power, the following results:

$$A_{sc} = \frac{(M.E.P.)_{ap} A_{ap} + (M.E.P.)_p A_p}{(1.00 - 0.33) (M.E.P.)_s} \text{ sq. ft.}$$

U. S. Navy Air Pumps.—Separate air pumps are often used. Fig. 16 shows the air cylinder of a stream-driven pump used in the U. S. Navy. This air pump is made with two air cylinders driven through gears from a steam cylinder placed on one side of a pump barrel.

The pump is of the bucket type with foot valves *AA* and head valves at *B*. These with the valves in the bucket at *C* are all spring-controlled metal valves. The foot valves are placed on an inclined partition for the purpose of making it easier to discharge the air when the piston rises and forms a vacuum. The lip around the discharge valve makes a dam and covers the valve with water. This makes them air tight. The other valves are also flooded, since all of the water on the bucket or that over the foot valves cannot be driven out, as the valves limit the motion of the bucket. On the down stroke of the bucket the pressure in the space above it soon falls to a low vacuum because it had been completely filled with water; this, then, causes the valves to open and take air from the lower portion of the cylinder. The air in the water also separates and rises to the top of the cylinder. Finally the bucket reaches the water below, and this is driven through the valve openings which are uncovered. It is seen that the air leaves first in this case. The water is struck by the bucket surface and will cause considerable shock if the pump is running too rapidly.

Edwards Air Pump.—To do away with shock and to decrease valve resistance, the Edwards air pump, Fig. 17, was introduced.

In this air pump water and air enter the space *A* at the bottom of the pump which is made conical in form. The piston *B*, which is driven from the steam piston by two rods *CC* extending over the shaft and crank, is provided with a conical bottom. As this piston descends there is a vacuum produced, so that when the top of the piston uncovers the openings *E*, air enters from the space *A* around the cylinder barrel, and as the conical bottom enters

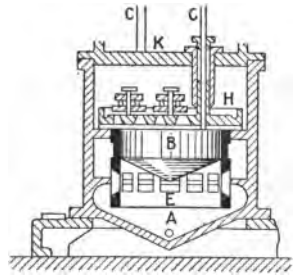

FIG. 17.—Edwards air pump cylinder.

the water in the bottom of *A*, this is forced around the curved passage and discharged into the openings at *E*. This continues even after the piston starts up, as the momentum causes the water to continue its motion. This discharge of water into the openings as the piston is moving upward acts as a valve to keep the air from coming out as the piston ascends. In a short time, however, the piston covers the ports or openings *E* and then the air and water are compressed until the pressure *E* is sufficient to overcome the atmospheric pressure on the head valves at *H*, which are flooded by means of a lip around

the valve deck. The piston rods *CC* are carried through long-sleeve stuffing-boxes so arranged that the point *H*, at which leakage could occur, is water sealed, leaving only one stuffing-box at the plate *K* to care for. This is a simple matter.

Industrial Uses of Vacuums.—One of the earliest applications of air pressure below the atmosphere is shown in a patent dated 1833, for the preparation of leather by the evaporation of certain substances in a partial vacuum, the object being to avoid intense heat. Water at atmospheric pressure boils at 212° F. If the pressure is increased above the atmosphere as in the ordinary boiler, the boiling-point of the water is raised, and for the same reason when it is desired to evaporate any substance at a temperature below its boiling-point for atmospheric pressure it is merely necessary to put the substances in a partial vacuum and its boiling-point is accordingly lowered.

This results in evaporation at very low temperatures, a most desirable feature especially in the drying of fruits, etc.

Air at pressures below the atmosphere is used for drying all kinds of food materials such as meat, fish, fruits, etc. Frequently a solution of a gelatin sugar or gum is used as a coating.

Vacuum processes are employed for pickling and salting meats and vegetables, evaporating fruits, refining sugar and condensing milk.

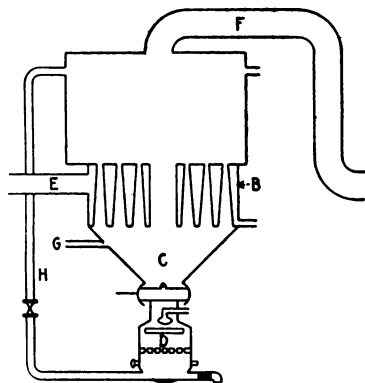

FIG. 18.—Vacuum manufacture of salt.

Wood may be artificially colored and railway timbers impregnated with preserving substances by means of a vacuum.

Salt Evaporating Effects.—Probably one of the most interesting applications of the partial vacuum is found in the manufacture of salt, the refining of sugar and the concentration of syrups, liquors, etc., by what is known as the triple effect apparatus.

The apparatus in which this is done usually consists of two or three "effects," as they are called, almost identical in construction. One of these is shown by Fig. 18 and represents one of a "train" of effects for extracting salt from brine by heating the brine solution, thereby evaporating the water and leaving the salt as a solid deposit.

B is the heating chamber or section consisting of a series of vertical flues, conical in section, in which the brine circulates and around

which the steam flows. This part is very similar in construction to a vertical flue boiler, with the exception that the flues are conical instead of cylindrical, to prevent deposits on the tubes.

Steam is furnished to *B* through pipe *E* either from a boiler or the exhaust of a steam engine, and after giving heat to the brine, which fills the apparatus as shown, the steam is condensed and drawn off. The vapor from the brine in the first effect passes through pipe *F* into the heating section of the second effect, gives heat to brine in the second effect and in doing so is condensed. This condensation of the vapor produces a partial vacuum in the first effect, thus lowering the boiling point of the brine in that effect and hence aiding evaporation.

The vapor of the brine of the second effect is conducted to the heating chamber of the third effect, imparts heat to the brine in that effect, producing a partial vacuum as in the first instance. The vapor from the third effect passes to an air pump. This air pump maintains a good vacuum in the third effect and in consequence the boiling-point of the brine in that effect is very low indeed.

The vacuum in the second effect is not good as in the third, and the boiling-point of the brine in that effect is a little higher. In the first effect the poorest vacuum exists and in consequence the brine here has the highest boiling-point of all and therefore requires the most heat, which is supplied to it from the boiler or the exhaust of the engine operating the air pump. It is because of the different boiling-points of the brine in three effects that the heat of the vapor of brine in the first effect is enabled to evaporate the brine in the second effect and the vapor of brine in the second effect is able to evaporate the brine in the third effect. In each one of the three effects of this apparatus salt is being extracted, the solid matter settling to the bottom of the chamber *C* from which it can be withdrawn by means of the two valves without disturbing the operation. The salt and some brine with it are deposited on a filter in the chamber *D*. The salt is here washed and the brine below the filter is returned to the evaporating chamber through *H*. The salt is then removed and a new supply of brine introduced through *G*. In this way the operations can be made practically continuous and in many plants automatic.

In some of the salt machines, instead of having two valves for withdrawing the salt without disturbing the partial vacuum, the lower part of the apparatus consists of a pipe running down such a distance that the partial vacuum will equal the hydrostatic head

and consequently the salt may be removed without the use of any valves whatever.

Concentration of Liquors.—In the concentration of syrups and of many liquors; it is highly important that the liquors should not be heated too highly or they will be scorched. To avoid this, the liquor is moved through pipes at a velocity so great that there is no opportunity for the syrup to become scorched.

In the concentration of liquors, a partial evaporation is secured in one effect and the vapor of the liquor separated from the liquor itself. Both vapor and liquor are then introduced into a second effect which has a lower pressure, and here the vapor from the first

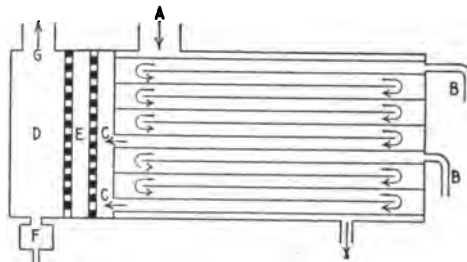

FIG. 19.—Vacuum concentration of liquors.

effect gives heat to its own liquor and the liquor is still further concentrated; the resulting liquor and vapor of this second effect are separated as in the first instance and introduced into a third effect where the concentration is carried still further. In some evaporators this is continued in a fourth effect and a still further concentration of the liquor secured.

Figure 19 shows an evaporator of the type just explained. The operation is as follows: The steam which may be either the exhaust from an engine or live steam from a boiler is led into the cylindrical chamber through *A*. The liquid to be concentrated is fed in through the tubes *B* and enters the evaporator in a small but continuous stream and immediately begins to boil violently, becoming a mass of spray containing, as it rushes along the heated tube, an increasing proportion of steam. The outlet of the tube *C* being at a lower pressure than *B*, the contents are propelled through the tubes at a high velocity, finally escaping into the separator *D*. Here the steam or vapor with its entrained liquid is discharged with considerable force against the baffle plates *E*, causing the liquid to be separated from the vapor, the concentrated liquor being drawn

off through a trap *F*, while the vapor escapes through *G* to enter the second effect where its heat still further concentrates the liquid, which is conducted from *F* of the first effect to the second effect, entering through pipes similar to *B*. The liquid is led from the bottom of the separator of the first effect into the coils of the second effect and is further concentrated, passing in this way through the entire system or "train."

The volume of the liquid is being continually reduced as it passes through these effects, and as the pressure falls in passing from one effect to the next the boiling-point is lowered. That in the last effect being the lowest of all, the required low pressure for this effect is secured by a vacuum pump. This relative reduction in pressure and consequently of the boiling temperature automatically adjusts itself, no matter how many effects are used, thus effecting the boiling of the liquid by the steam produced from the same liquid when in the preceding "effect."

One of the advantages claimed for this system of evaporation of a liquid in the form of a spray subjected to heat under a vacuum is that it receives the heat quickly and is concentrated slightly at one temperature, then still more at the lower temperature of the next effect, and so on, thus reducing the danger of overheating. The rapid movement of the liquid aided by the vapor which is moving in the same direction keeps the liquid in the form of a spray, thus taking up very quickly the heat given to it.

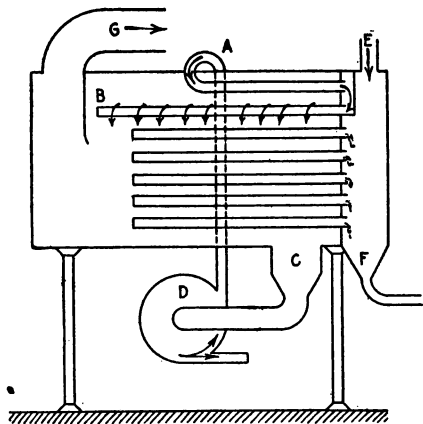

FIG. 20.—Vacuum concentration of liquors.

Evaporation of Cane Juice.

—The cross-section of a still

different type of evaporator is shown in Fig. 20. The liquid or cane juice is introduced through *A* and is sprayed from holes in pipe *B* over a series of steam-pipes. The partially concentrated liquor falls into chamber *C* and is drawn from there by a centrifugal pump *D* and forced into the next effect through a pipe similar to *A* and *B* of the first effect. Steam for heating the first effect is introduced through pipe *E* and, after imparting heat to the liquor, is condensed. The

water falling to the bottom, as shown, is drawn off through *F*. The vapor from the liquor that has been partially concentrated escapes through *G* and is introduced to the heating chamber of the second effect through a pipe corresponding to *E* of the first effect. As the pressure of the second effect is lower than the pressure of the first effect, the condensed steam from this effect is also introduced into the second effect, and, being at a temperature above that of boiling-point of water at this lower temperature, it gives heat to this effect and helps to evaporate the liquor in it.

Vacuum Cleaners.—One of the most recent applications of air at pressure below the atmosphere consists of vacuum cleaners of various types for removing dust and dirt from floors and walls, furniture, etc., in buildings. Although many types of machines for producing the required vacuum are on the market, they may be grouped under two heads, namely, portable and stationary types. In the former type of vacuum cleaner, the machine is moved about the room, drawing dust and air through a pump and discharging

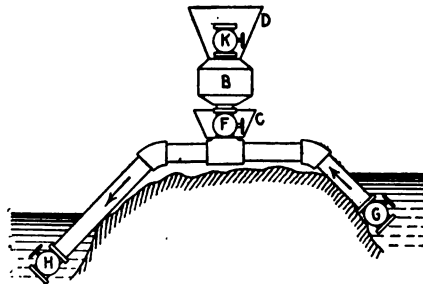

FIG. 21.—Syphon.

into a cloth receptacle, from which the air can escape and in which the dust is trapped. This type of cleaner has the advantage that it is comparatively cheap, but has a disadvantage in that germs are discharged with the air into the room, and from the hygienic point of view this is considered objectionable.

The objection mentioned is removed in the second type of cleaner, in which the machine is permanently located in the basement of the building and vacuum pipes lead to the various rooms and floors, to which the hose and cleaning tools are attached. This type of machine is naturally more expensive, but finds considerable favor in large office and hotel buildings.

The piston type of air pump is used as well as fans, bellows, and

rotary blowers. This field of usefulness for air at low pressures has increased to a remarkable extent, but the industry cannot yet be said to be on a fixed basis; that is, there is still considerable information needed regarding the proper suction pressures to secure the requisite cleanliness without injuring the fabric of rugs and hangings.

Syphon.—A discussion of the uses of air at pressures below the atmosphere would not be complete without some reference to the syphon (Fig. 21). *B* is an air chamber, *C* a water seal for the valve *F*, *D* a funnel for filling the syphon and also for sealing valve *K* against air leakage. After the syphon has been filled, valve *K* is closed and *G* and *H* opened. This starts the syphon in operation. The air that comes in with the water and through the joints of the pipe collects in chamber *B* and may be discharged by closing valve *F*, opening valve *K*, and filling chamber *B* with water. Then close valve *K* and open valve *F* and any air below *C* will rise into chamber *B* and the water will take its place without stopping the running of the syphon.

CHAPTER VI

AIR AT LOW PRESSURES

Uses of Air at Low Pressures.—Probably the principal uses made of air at low pressure are for cupolas, furnaces, blacksmith fires, for conveying light materials, as shavings, etc. A very large field for air at low pressure is for purposes of ventilation for school buildings churches, theaters, assembly halls, factories, mines and tunnels, etc. Its use in this field dates back to the sixteenth century, and while for many years very little thought was paid to it, to-day considerable attention is paid to the subject of ventilation. In fact, no heating system for home, school-house, factory or office building is complete without some system for removing the foul air and replacing it with fresh air.

To secure the necessary movement of air in buildings where the number of cubic feet of room per person is a limited quantity, a positive circulation is secured by introducing the fresh air at a pressure a few ounces above the atmosphere into the room, or by drawing the foul air from the room by means of an exhaust fan.

Compressors for Low Pressures.—The principal machines used for moving air for ventilation and other purposes, either by pressure or suction, are: the centrifugal fans or blowers, the positive blower of the piston or rotary type, and the jet pumps from which are discharged jets of steam or compressed air. The requirements for good ventilation demand that large volumes of air must be moved at comparatively low velocity and pressure, which is not a favorable condition for high efficiency and can in general be better satisfied by a centrifugal fan or blower than by any other machine; it may also be stated that the fan is comparatively cheap to install, is simple in construction and possesses a fair efficiency.

Tables giving requisite information regarding fans for various purposes can be secured from any of the fan manufacturers, and engineering handbooks usually contain considerable data taken largely from these catalogs.

It is well to remember, however, that these tables are apt to over-rate the capacity and under-rate the required power for operation. Centrifugal fans are in use furnishing air at pressures varying from $1/4$ oz. to 20 oz., and are constructed in all sizes, the largest, of course, being used where large volumes of air are to be moved at very low velocity.

Air for Forges.—An article by William Sangster in the Transactions of the American Society of Mechanical Engineers, in Volume 22, page 354, gives the following approximate rules of the air required for forges and cupolas. The maximum pressure required for forges is about 4 oz. per square inch, the ordinary pressure about 2 oz.; 140 cu. ft. of free air per minute is ample and it is estimated that it requires about $1/4$ h.p. to furnish air for an ordinary forge. It is customary to estimate that an exhaust fan for a blacksmith-shop must remove four times the amount of air delivered at a pressure of $3/4$ oz., and that to do this will require about $1/5$ h.p. per forge. Roughly speaking, if the number of forges is divided by 4, the horse-power required to furnish the blast can be found, and if the number of forges is divided by 5, the horse-power required to exhaust the smoke can be found.

These exhaust fans run at a much slower speed than the pressure fans and as the pressure of the exhaust air is much lower than the blast the power required for their operation is less, although they move four times the volume that the pressure fans do. In some installations one fan does the work of forcing the blast and exhausting the smoke, but as the requirements of a blast fan are so different from those of an exhaust fan, such a combination is not economical.

Air for Cupolas.—The air required to melt iron in cupolas may be taken as 40,000 cu. ft. per ton of iron melted, and the horse-power required as three-tenths of the number of tons to be melted per hour, multiplied by pressure of the blast in ounces per square inch. It is well to remember that these figures do not take account of losses in the piping system. These results will, no doubt, fall far short if the pipe system is poorly designed with sharp elbows, small diameters, etc.

Air for Ventilation.—In estimating air required for ventilation, the data in Table IV is frequently used:

TABLE IV.—AMOUNT OF AIR REQUIRED FOR VENTILATION

Allowable parts of carbonic acid in 10,000 of air in room.	Cubic feet of air required per person	
	Per minute	Per hour
5	100	6,000
6	50	3,000
7	33	2,000
8	25	1,500
9	20	1,200
10	16	1,000

TABLE V.—AIR SUPPLY FOR VARIOUS BUILDINGS

Air supply per occupant for	Cubic feet per minute	Cubic feet per hour
Hospitals.....	80 to 100	4,800 to 6,000
High schools.....	50	3,000
Grammar schools.....	40	2,400
Theaters and assembly halls.....	25	1,500
Churches.....	20	1,200

TABLE VI.—AIR SUPPLY FOR VARIOUS ROOMS

Use of room	Changes of air per hour
Public waiting-room.....	4 to 5
Public toilets.....	5 to 6
Coat and locker-rooms.....	4 to 5
Museums.....	3 to 4
Offices, public.....	4 to 5
Offices, private.....	3 to 4
Public dining-rooms.....	4 to 5
Living-rooms.....	3 to 4
Libraries, public.....	4 to 5
Libraries, private.....	3 to 4
Fuming cabinets for chemical laboratories.....	30 to 60

The following material on fans and blowers is taken from a lecture by Mr. H. de B. Parsons, Consulting Engineer, delivered before the Junior Class of Columbia University:

FANS OR BLOWERS

"A fan or blower is a machine for impelling gas, *i.e.*, for producing a current of gas. In the majority of cases the gas impelled is air.

"There are many purposes for which a fan is used, such as for heating, cooling and ventilating buildings, either by exhausting air from, or forcing air into, the apartments; for blowing the fire of a forge or cupola; for creating artificial draft for fuel combustion; for work pertaining to drying; for carrying away obnoxious gases and discharging them at a point where they will not create a nuisance; for carrying away grindings and waste products so that they may not affect the workmen; for conveying light materials, such as sawdust and small particles, and permitting them to settle in dust chambers; and for the circulation of air in mines and places where explosive gases may collect.

"When fans are properly selected for their work they will give satisfactory and economic results, and will require little attention for maintenance.

"The conditions of pressure and density of the gas and of speed and capacity of the fan govern the size, type and proportion of the fan and its housing. These conditions are closely related, and all affect the design that should be selected. Even moderate differences in the conditions of operation will have considerable effect upon the power necessary to drive the fan. It therefore follows that a fan should be designed for the conditions under which it is to operate, and conversely, that a fan should be operated under the conditions for which it was designed.

"Fans are not economical machines to operate against high pressures. In such cases a blowing engine or compressor will be the better."

Classification

"There are a number of types in use, but nearly all blowers and fans can be classified under one of the following heads:

- (1) Rotary blowing machine.
- (2) Disc, axial or propeller wheel fan.
- (3) Centrifugal fan, either a fan blast or cone wheel.
- (4) Turbine blast or high-speed centrifugal fan.

"Type (1) is a positive or displacement discharge machine, and is a blower or exhauster.

"Type (2) is an axial discharge fan.

"Type (3) and (4) are peripheral fans.

"All of the types can be used for exhausting or for blowing, although some are less suitable for exhausting than others. There is a material difference in the selection of a type for an exhaust

machine, when pressures above the atmosphere on the discharge side of the fan are considered. The disc fan makes a good exhauster when a pressure above that of the atmosphere does not have to be maintained on the discharge side, but when such a positive pressure has to be maintained a centrifugal machine is the more suitable.

Definitions

“There are certain terms used in fan work which are recognized as having specific meanings.

“**Fan Pressure or Draft.**—Fan pressure or draft means the difference between the pressures on the suction side and on the discharge side of a fan. The difference in pressure is expressed either in ounces per square inch or inches of water.

“When a fan is used as an exhauster discharging into the atmosphere, there will be a partial vacuum on the suction side and slight pressure on the discharge side. In this case the vacuum is expressed as the number of ounces or inches of water below the atmosphere, and the fan pressure or draft is measured by the difference. It is just the same as if the suction were at atmospheric pressure and the discharge at the same number of ounces above the atmosphere.

“**Fan Capacity.**—Capacity means the maximum discharge of free air from a fan in cubic feet per minute against a pressure corresponding to the speed of the tips of the blades. This condition is satisfied in the case of a centrifugal machine when the velocity of the gas entering the inlet is equal to the velocity of the inner edge of the floats at inlet.

“**Housing.**—The casing in which a fan operates is called the ‘housing.’ It is made of metal, of brick, or of wood. Frequently the fan is so set as to project into its foundation, and in such cases the casing only covers the portion which projects above the foundation. The fan is then said to have a three-quarter housing. Of course the inlet must be above the foundation or a free passage must be provided to it.

“**Free Discharge.**—A fan is said to have free discharge when the blast is free or unrestricted. This condition is maintained when the total head is practically equivalent to the velocity head. The total head is equal to the velocity head plus the friction head, and with a free discharge head the friction head is practically zero.

“**Restricted Discharge.**—A fan is said to have a restricted discharge when the blast is restricted by ducts or by pressure reservoirs.

“**Free and Restricted Suction.**—Similarly to free and restricted discharge, a fan may have either a free or a restricted suction, whereby the gas has either a free or unrestricted entrance into the fan, or a restricted entrance caused by ducts or a reduction in the pressure on the suction side.

“Coefficient of Contraction.—The ratio of the area of the vena contracta to the area of the orifice is called the ‘coefficient of contraction.’

“Coefficient of Velocity.—As the stream of gas passes the vena contracta its velocity is somewhat increased, and the ratio of the actual velocity to the theoretical velocity is called the ‘coefficient of velocity.’ In a well-shaped delivery orifice this coefficient of velocity is not far from unity.

“Coefficient of Efflux.—The ‘coefficient of efflux’ is the product of the coefficient of contraction and the coefficient of velocity.

“Volume of Discharge.—The volume of gas discharged by a fan is a function of the product of the velocity of the gas times the area of the outlet, times the coefficient of efflux.

“Blast Area.—The blast area of a fan is the theoretical area of outlet whose coefficient of efflux is unity. The volume of discharge is equal to the blast area times the velocity of discharge. Therefore, the blast area equals the capacity divided by the velocity due to the velocity head. The stream of gas issuing through an outlet is reduced in area, depending on the shape and character of the orifice. This reduced area is called the ‘vena contracta’ and is usually at a distance from the opening of about half its diameter. This vena contracta is caused by the change in direction of the flow of the molecules of the gas as they pass the opening.”

Measurement of Draft

“The measurement of draft, either static or both static and velocity pressures is obtained by noting the difference in level of a liquid in the arms of a tube bent on the form of a U, of which one end is connected with a proper tube to the space in which the draft is to be measured. The liquid is generally water although for heavy pressures mercury is sometimes used.

“There are different forms of gages which can be bought in the market but for ordinary work the simplest forms are the best. Some of these instruments are so made that they will give a continuous record, and for certain kinds of work these continuous records are of considerable value.

“Anemometers are used for measuring the velocity of the gas. Readings should be taken at many points in the cross-section of the current, and even at the same points consecutive readings will not agree. Multiple readings therefore should be made in order to average up these irregularities.

“Fan draft is always expressed in ounces per square inch or in inches of a water column whose weight is equal to the ounces per square inch. The velocity corresponds to this pressure, when the friction head is zero.

“When the pressure exceeds two or three pounds per square inch as is the case with many positive blowers, the pressure is then generally expressed in ‘pounds per square inch.’

TABLE VII.—PRESSURES IN OUNCES PER SQUARE INCH
Corresponding to Various Heads of Water in Inches

Head in inches	Decimal parts of an inch									
	0.0	0.1	0.2	0.3	0.4	0.5	0.6	0.7	0.8	0.9
0	0.06	0.12	0.17	0.23	0.29	0.35	0.40	0.46	0.52
1	0.58	0.63	0.69	0.75	0.81	0.87	0.93	0.98	1.04	1.09
2	1.16	1.21	1.27	1.33	1.39	1.44	1.50	1.56	1.62	1.67
3	1.73	1.79	1.85	1.91	1.96	2.02	2.08	2.14	2.19	2.25
4	2.31	2.37	2.42	2.48	2.54	2.60	2.66	2.72	2.77	2.83
5	2.89	2.94	3.00	3.06	3.12	3.18	3.24	3.29	3.35	3.41
6	3.47	3.52	3.58	3.64	3.70	3.75	3.81	3.87	3.92	3.98
7	4.04	4.10	4.16	4.22	4.28	4.33	4.39	4.45	4.50	4.56
8	4.62	4.67	4.73	4.79	4.85	4.91	4.97	5.03	5.08	5.14
9	5.20	5.26	5.31	5.37	5.42	5.48	5.54	5.60	5.66	5.72

TABLE VIII.—HEIGHT OF WATER COLUMN IN INCHES
Corresponding to Various Pressures in Ounces per Square Inch

Pres- sure in oz. per sq. in.	Decimal parts of an ounce									
	0.0	0.1	0.2	0.3	0.4	0.5	0.6	0.7	0.8	0.9
0	0.17	0.35	0.52	0.69	0.87	1.04	1.21	1.38	1.56
1	1.73	1.90	2.08	2.25	2.42	2.60	2.77	2.94	3.11	3.29
2	3.46	3.63	3.81	3.98	4.15	4.33	4.50	4.67	4.84	5.01
3	5.19	5.36	5.54	5.71	5.88	6.06	6.23	6.40	6.57	6.75
4	6.92	7.09	7.27	7.44	7.61	7.79	7.96	8.13	8.30	8.48
5	8.65	8.82	9.00	9.17	9.34	9.52	9.69	9.86	10.03	10.21
6	10.38	10.55	10.73	10.90	11.07	11.26	11.43	11.60	11.77	11.95
7	12.11	12.28	12.46	12.63	12.80	12.97	13.15	13.32	13.49	13.67
8	13.84	14.01	14.19	14.36	14.53	14.71	14.88	15.05	15.22	15.40
9	15.57	15.74	15.92	16.09	16.26	16.45	16.62	16.79	16.96	17.14

Fan Efficiency

“In the operation of a fan or blower there are certain losses which must exist, the principal losses being:

“1. Fluid friction and eddies caused by the movement of the gases.

“2. Leakage of the gases backward through the fan or blower. This is sometimes called the ‘slip.’

“3. Mechanical friction of the moving parts of the apparatus.

“Generally speaking, these losses increase with the speed of revolution of the fan and also as the difference in pressure between the suction and discharge sides increases.

“The efficiency of a fan or blower is the ratio of the useful work done on the air divided by the work required to drive the fan. Fans are generally driven by steam engines or by motors, and frequently the denominator of the efficiency ratio includes the work of driving the engine or motor. Such an efficiency is really the combined efficiency of the prime mover and fan.

“The efficiency of a fan wheel with a housing varies with the ratio of diameter of inlet to diameter of wheel. The smaller this ratio the greater will be the theoretical efficiency so long as the area of outlet times the coefficient of efflux is not less than the blast area.

“When a centrifugal fan has to work against high pressures, it is desirable, therefore, that the ratio of inlet to wheel diameter be small in order to get the benefit of this increase in efficiency.”

Flow of Gas Through an Orifice

“Gas flowing through an orifice does not obey the same law as the flow of fluids. The reason of this is that gas expands from the higher pressure to the lower pressure as it issues through the orifice.

“Imagine the gas in a reservoir R (Fig. 22) flowing from the short cylindrical orifice of section a . Imagine that the reservoir is kept supplied with gas so that its pressure remains constant. Suppose that the division S represents a pound of gas.

“As the gas escapes through the orifice a , the pressure is kept constant, and the work $OAEQ$ has been done upon the gas. The gas in expanding develops the expansive work $EIMQ$, EI being an adiabatic curve.

“The outer pressure P_2 absorbs the work $INOM$, and the balance, $AEIN$, is devoted to accelerating the particles of the pound of gas to a velocity v .

“Hence the work $AEIN$ equals the actual energy of 1 lb. of gas moving with a velocity of v ft. per second or

$$AEIN = (1 \text{ lb.}) \times \frac{v^2}{2g}$$

Therefore $v = \sqrt{2g(AEIN)}$ ft. per second

Taking the law of the curve EI as $p_1 v_1^n = p_2 v_2^n = \text{constant}$ we have:

$$AEIN = \frac{n}{n-1} \times 144 p_1 S \left[1 - \left(\frac{p_2}{p_1} \right)^{\frac{n-1}{n}} \right]$$

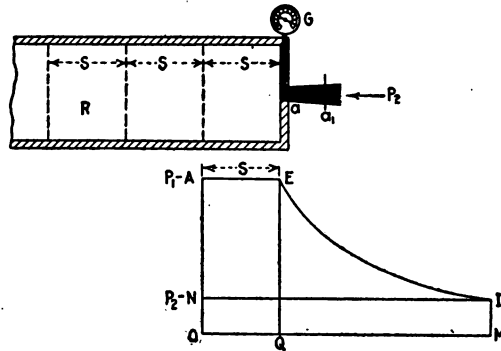

FIG. 22.—Flow of gas through an orifice.

“Letting $n = 1.405$ the ratio of the specific heats and the exponent in adiabatic changes of air

$$v = \sqrt{2g \times \frac{1.405}{0.405} \times 144 p_1 S \left[1 - \left(\frac{p_2}{p_1} \right)^{0.288} \right]}$$

$$v = 179 \sqrt{p_1 S \left[1 - \left(\frac{p_2}{p_1} \right)^{0.288} \right]} \text{ ft. per second}$$

“It is found by taking the pressure at the orifice by a gauge G that if the gas flows into another reservoir kept at the back pressure p_2 the orifice pressure is identical with p_2 if the latter is more than about $0.58 p_1$. That is, if p_1 is 100 lb. per square inch absolute, any value of the back pressure greater than about 58 lb. gives this pressure to the orifice, but if the back pressure is the atmosphere the orifice pressure remains 58 lb.

“It therefore follows that for $\frac{p_2}{p_1} < 0.58$ the velocity given by the above formula exists at some point of the jet beyond the orifice at

a section $a_1 > a$ due to the natural spread of the jet, while the velocity at the orifice or throat of the jet is that given by the formula for

$$\frac{p_2}{p_1} = 0.58.$$

Loss of Head Due to Friction in Ducts

“The frictional resistance to the movement of a gas in a duct is proportional to the surface of the duct. It is, therefore, directly proportional to length and inversely proportional to diameter. It also varies as the square of the velocity.

“Therefore, the ducts should be of ample area, or the power lost in friction will be very great. Small pipes and high velocities should be avoided.

“It is evident that after a certain size of duct is reached, any further change in size or velocity of movement will only have a relatively small effect upon friction loss. The limit, therefore, is reached when the increase in space required and the cost will turn the saving in friction into a loss from a commercial standpoint.

“**Usual Velocity in Ducts.**—In heating and ventilating work for theaters, hospitals, churches and large buildings, the limiting velocities usually selected are:

- | | |
|---------------------------------------|----------------------|
| (a) In ducts leading from force fans— | |
| In horizontal main ducts..... | 1,600 ft. per minute |
| In horizontal main branches..... | 1,300 ft. per minute |
| In horizontal branches to risers..... | 650 ft. per minute |
| In vertical risers..... | 800 ft. per minute |
| (b) In ducts leading to exhaust fans— | |
| In vertical risers..... | 800 ft. per minute |
| In horizontal ducts to fan..... | 1,000 ft. per minute |

“The frictional loss in ducts can be calculated from the formulæ for the movement of fluids. In addition to the friction loss of head caused by the passage of a gas through a straight duct, there is a loss at each bend or change of section.

“In order to overcome these friction losses, it is necessary that the pressure at the fan end of the duct should equal the sum of the pressure desired at the open end of the duct, and the pressure necessary to overcome the losses in frictional head.

“In all the following formulæ the following notation has been used.

Notation of Symbols

A denotes the area of the duct in square inches.

a denotes the blast area, or the ‘effective area of discharge’ in square inches.

- B* denotes the diameter of duct in inches.
C denotes the perimeter of duct in inches.
c denotes a constant.
D denotes the diameter of the fan wheel in inches.
d denotes the density of the gas, *i.e.*, its weight in pounds per cu. ft.
E denotes the combined efficiency of fan and its prime mover.
e denotes fan efficiency, or ratio of useful work to work of driving fan.
g denotes the acceleration due to gravity in feet at the end of one second, 32.16 ft.
h denotes the equivalent head, *i.e.*, the height of a column of gas in feet having a density *d*, whose weight will produce the velocity pressure *p* ounces per square inch.
K denotes the capacity of a fan in cubic feet per minute.
l denotes the length of duct in feet.
n denotes the number of revolutions per minute of fan wheel.
P denotes the total pressure against which a fan is working.¹
p denotes the velocity pressure in ounces per square inch (or inch of water) against which a fan is working.¹
t denotes the absolute temperature, or 460° + F.
Q denotes the volume of gas discharged by a fan in cubic feet per second.
V denotes the peripheral velocity of fan wheel in feet per second.
v denotes the velocity of gases in feet per second due to pressure *p*.
W denotes the width of fan wheel in inches.
w denotes the width of blades of fan wheel at periphery in inches.

"Pipe Losses.—Frictional losses are very hard to calculate, as so much depends on the smoothness of the surface and the material of which the ducts are made.

"The loss due to surface friction can be estimated from the formulæ;

"For circular ducts of galvanized iron, carefully made,

$$p = \frac{lv^2}{25,000 B}$$

"For rectangular ducts of galvanized iron, carefully made,

$$p = \frac{lv^2 C}{100,000 A}$$

in which *p* denotes the loss of pressure in ounces per square inch. This is an empirical formula based on Weisbach's general formula for the flow of fluids.

¹ The total pressure against which the fan is working is *p* + *p_s*, in which *p_s* is the static pressure.

“Bends create an additional loss which are hard to estimate. For all practical purposes the frictional loss due to bends can be estimated sufficiently accurately as follows, when the ducts are of galvanized iron, carefully made and of fairly smooth surface:

(a) For right-angle bends with the radius at the root of the bend equal to one duct diameter, allow an equivalent length of straight pipe equal to 11.1 times the diameter of the duct. Thus in Fig. 23 if $B = 20$ in., allow for the bend 11.1×20 or 222 in. or 19 ft. of pipe.

(b) For right-angle bends with a radius at the root of the bend equal to one-half the duct diameter, allow an equivalent length of straight duct equal to 29.5 times the diameter of the duct.

(c) For 45-degree bends allow one-third of the loss for right-angle bends.”

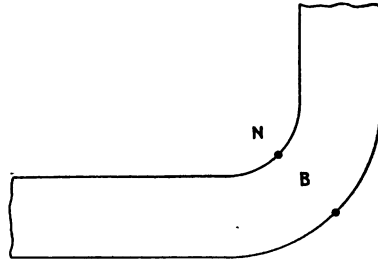

FIG. 23.—Right angle bend resistance.

Rotary Blowing Machines

“A rotary blower is a positive pressure blower or exhaustor, and is not a fan, although it is used for similar purposes. It is positive in its action and it operates by displacement.

“A rotary blower costs more than a fan of equal capacity, but it is more economical than a fan when operating against high pressures, that is 8 oz. per square inch or more. Turbine blowers, however, are now being built giving efficiencies fully equal to that of rotary blowers. (See Chapter XI).

“A rotary blower is more economical than a compressor when operating against pressures less than 7 lb. per square inch. Generally speaking, the compressor is more economical at pressures in excess of 7 lb.

“Rotary blowers can be arranged to give constant pressures or constant volumes. They can also handle liquids as well as gases.

“A rotary blower (Fig. 24) consists of a casing in which two impellers revolve in opposite directions. Each impeller is of a double-lobe section symmetrical with its shaft. The impellers are set so that the lobe of one impeller fits into the recess of the other. The impellers do not touch each other, nor do they touch the casing,

although they should work as close as is possible without touching so as to prevent loss through leakage.

"The air is drawn in through the inlet, is caught between the lobe of an impeller and the casing and forced around as the impeller revolves, and discharged through an opening situated in the casing diametrically opposite to the inlet. In order to keep the impellers at their proper relative speeds, one shaft is driven by the other shaft through a pair of gears.

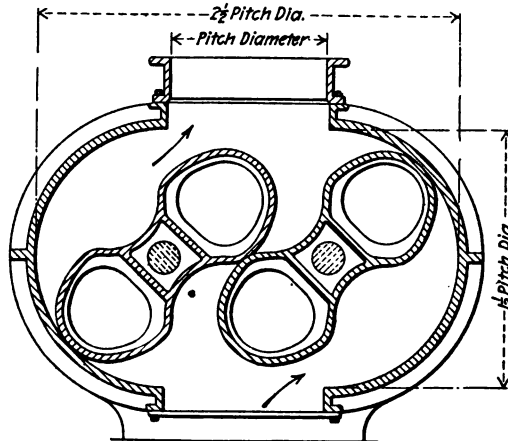

FIG. 24.—Cross-section through standard blower.

"The pitch diameter of these gears controls the size and capacity of the machine. The radius of an impeller, or its half length, is made three-quarters of the pitch diameter of the gears. The casing consists of two semi-cylinders separated by a parallel section. The radius of the cylinders is equal to that of the impellers plus clearance. The width of the parallel section is equal to the pitch diameter of the gears plus the clearance. The speed of revolution is regulated by the safe speed at which the gears can be operated.

"**Blower Pressures and Capacities.**—The limit of the gas pressure, in commercial sizes, is about 12 lb. per square inch. The standard commercial sizes have capacities varying from one-quarter of a cubic foot to 400 cu. ft. per revolution.

"Two of the types of rotary blowers in use, are described by the shapes of the ends of the impellers, as cycloidal or involute. When the impeller ends are cycloidal they fit close to each other and leave no waste spaces or pockets. Such machines are adapted to handle wet gases and liquids as well as dry gases. When the impellers are cycloidal, the capacity per each revolution is equal to

the area of the pitch circle of the gears times the length of the cylinder.

“When the impellers are involute, the capacity is somewhat greater than the cycloidal and depends on the diameter of the generating circle for the involute. This diameter is variable to suit the duty of the blower.

“The slip is largest in small machines, and least in large ones. Thus for machines displacing three-quarters of a cubic foot per revolution at 1-lb. pressure the slip is about 60 to 70 revolutions, *i.e.*, the machine has to make that number of revolutions to hold the pressure against leakage. For machines displacing 300 cu. ft. per revolution at 1-lb. pressure, the slip is from 3 to 5 revolutions. The slip for intermediate sizes is about proportional and for pressures other than 1 lb. the slip will vary closely as the square root of the pressures.

“For cycloidal types, the casing is 1 1/2-pitch diameters high by 2 1/2-pitch diameters wide. For involute types, the casing section is nearly the same, but depends on the circle on which the involute is rolled, and this depends on the duty for which the machine is designed.

“The efficiency is variable, and for the larger sizes is between 80 and 86 per cent. falling off gradually as the pressures exceed 3 lb. per square inch. For smaller sizes the efficiency is less.

“**Power for Rotary Blowers.**—The horse-power required at the shaft or pulley to drive a rotary positive blower is proportional to the volume and pressure of the air discharged. It is safe to assume that for each 1,000 cu. ft. of free air discharged per minute at 1-lb. pressure, 5 h.p. is required. The following formulæ are sometimes used in calculating the horse-power. The first two formulæ give the theoretical horse-power required; and in order to determine the horse-power necessary to drive the rotary positive blower it is necessary to divide the results obtained by the efficiency of the machine. The usual efficiency is between 80 and 90 per cent.

$$(1) \text{ h.p.} = \frac{QP_1 \left[\left(\frac{P}{P_1} \right)^{\frac{1}{3}} - 1 \right]}{11,000}$$

“This formula is used when it may be assumed that the air is compressed so quickly that it does not have time to cool to atmospheric temperature, as in nearly all blower work.

$$(2) \text{ h.p.} = \frac{Q(P - P_1)}{33,000}$$

“This formula is the ordinary “hydraulic formula” and is ordinarily used for pressures up to 5 oz.

$$(3) \text{ h.p.} = \frac{\text{lb. per sq. in.} \times Q}{200}$$

“This formula is frequently used by makers of positive or rotary blowers for determining the horse-power required to operate the machine. In this formula Q represents the volume of air in cubic feet per minute displaced by the impellers, no allowance being made for slippage. In the above formulæ P_1 represents the pressure of

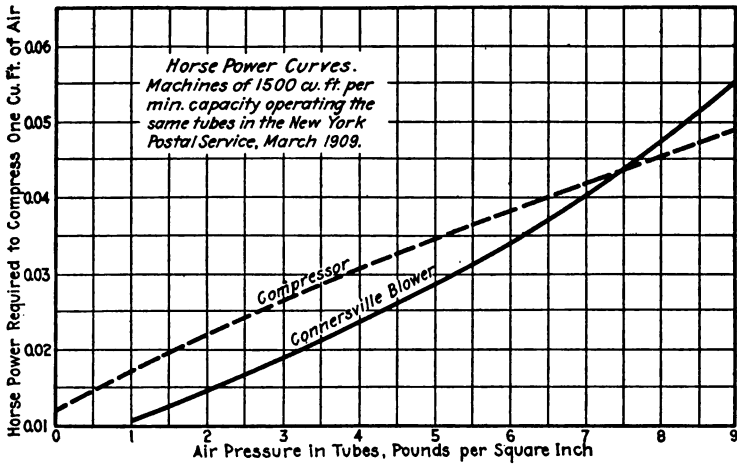

FIG. 25.—Power consumed by rotary and piston compressor.

the atmosphere or the suction pressure absolute in pounds per square foot and P the compression or discharge pressure in the same units. (See Fig. 25.)”

Mechanics of the Fan

“The laws that govern the flow of gases are the same as those for the movement of liquids. If p , the pressure in ounces per square inch, is divided by 16 and this result multiplied by 144, the pressure will be expressed in pounds per square foot. This may also be done by multiplying d or the weight in pounds of one cubic foot of the gas by its height or head h expressed in feet.

That is:

$$\frac{144}{16} p = hd, \quad 9p = hd, \quad h = \frac{9p}{d}$$

and as the fundamental formula for velocity is $v^2 = gh$.

$$v = \sqrt{2 gh} = \sqrt{18 g \frac{p}{d}}$$

“When p is given in inches of water:

$$\frac{62.4}{12} p = hd; \quad h = \frac{5.2p}{d}$$

Therefore

$$v = \sqrt{10.4 g \frac{p}{d}}$$

“The theoretical velocity obtained by using this last formula is greater than the actual velocity produced by the fan, because friction and eddies will restrict the freedom of flow. The formula, however, shows that the flow of gases through an orifice increases as the square root of the pressure and inversely as the square root of the density.

“The head is made up of two parts—that necessary to overcome the friction and eddy losses and that necessary to produce the velocity obtained.

“The pressure produced by a fan may be considered as equal to the weight of a column of gas one square foot in area which the fan is supporting. This weight is equal to the height of the column times the density of the gas. The “equivalent head” is the height of this column of gas. Therefore, for any given pressure, the greater the head the less will be the density, and *vice versa*. Also, the greater the head required to produce a given pressure the greater will be the velocity.

“As liquids have greater densities than gases, their equivalent heads for equal pressures will be less than the equivalent heads for gases. As velocities vary as the square roots of the head, the velocity of gases will be greater than those of liquids under the same conditions of pressure. That is the reason why gases issue through orifices at greater velocity than liquids under the same pressure conditions.

“As gases are compressible, their density will vary with the pressure. Their density also varies with the temperature and with the humidity contained. Since the velocity varies as the square root of the head, and as the head varies inversely as the density, any increase in density due to increase in pressure will reduce the head and consequently the velocity.

“Conversely any increase in temperature reduces the density and consequently increases the head and also the velocity. The velocity is entirely dependent upon the head. Therefore, in making calculations for fan operations the effect of both temperature and density must be considered. For fan operation the standards generally adopted are: for temperature 60° F. and for density the weight of a cubic foot in pounds at atmospheric pressure or 14.7 lb.

per square inch absolute. When the density of the gas is given for any pressure and temperature its density at any other pressure or temperature can be found with sufficient accuracy for all ordinary fan operations, by assuming that the density will vary inversely as the absolute temperatures, and directly as the absolute pressures.

$$\text{Thus } d_1 = \frac{td}{t_1}$$

“If a cubic foot of dry air weighs 0.077884 lb. at 50° F. its weight at 600° would be $d_1 = \frac{(50+460) \times 0.077884}{600+460} = 0.03751$ lb.

“Also, as the density varies directly as the absolute pressure

$$d_1 = \frac{p_1 d}{p}$$

“The pressure per square inch at atmospheric pressure is 14.7 lb. absolute or 235 oz. Therefore, the density at 3 oz. gauge pressure would be:

$$d_1 = \frac{(235+3) \times 0.077884}{235} = 0.0788$$

“The head can be expressed for 50° F. when p is given in ounces per square inch thus:

$$h = \frac{144 \times p}{16 \times d \times \frac{235+p}{235}} = \frac{9 \times p \times 235}{d \times (235+p)} = \frac{2115p}{(235d+dp)}$$

“When p is expressed in inches of water as

$$h = \frac{\frac{62.4}{12} \times p}{d \times \frac{406.7+p}{406.7}} = \frac{5.2 \times p \times 406.7}{d \times (406.7+p)} = \frac{2115p}{406.7d+pd}$$

“Since 62.4 lb. the weight of a cubic foot of water at 50° F. divided by 12 is the weight of a column of water 12 in. square and 1 in. high, and since the pressure at one atmosphere (14.7) would sustain a column of water 33.9 ft. or 406.7 in. high;

“Substituting these values in the formula for velocity and expressing p as the velocity pressure in ounces per square inch

$$v = \sqrt{2g \times \frac{2115p}{235d+dp}} = \sqrt{\frac{64.32 \times 2115p}{(235+p)d}} = \sqrt{\frac{136036.8p}{(235+p)d}}$$

When p is expressed in inches of water

$$v = \sqrt{2g \times \frac{2115p}{406.7d + dp}} = \sqrt{\frac{64.32 \times 2115p}{(406.7 + p)d}} = \sqrt{\frac{136036.8p}{(406.7 + p)d}}$$

For dry air at 50° F. $d = 0.077884$.

“These two formulæ are those used to calculate tables giving the theoretical velocities expected at different pressures. If the gas is not dry, but contains some vapor or moisture, its density will vary

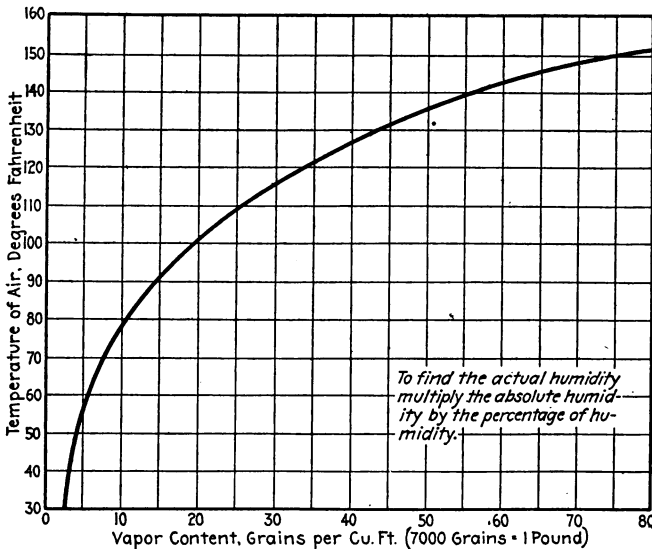

FIG. 26.—Humidity of air.

by the quantity of moisture which it contains, Fig. 26. (See Appendix C and chart.)

“If the gas is at any other temperature than 50° F. its density will decrease as the temperature rises, and conversely will increase as the temperature falls. As the temperature varies so will the velocity. As the gas becomes lighter from increases of temperature, the velocity will increase as the square root of the ratio of the absolute temperature considered to the absolute temperature of 50° F. The converse is also true, as the gas becomes heavier from decreases of temperature, the velocity will decrease in the same ratio.”

Effect of Outlet on Capacity

“The shape of the opening through which the gas is discharged from a fan affects the volume discharged in a given time. The

shape of the orifice and the form of the duct affect the size of the vena contracta and therefore the blast area of the fan and the volume of the gas discharged.

"As stated, the volume of discharge is a function of the product of the blast area times the velocity and the blast area is determined by multiplying the area of the orifice by the coefficient of efflux. The coefficients of efflux commonly used in practice for different types of orifices are:

Orifice in a thin plate.....	0.56
Short cylindrical pipe.....	0.75
Rounded off conical mouth piece.....	0.98
Conical pipe, angle of convergence about 6 degrees.....	0.92

"With peripheral discharge fans, when the area of the outlet of a fan multiplied by the proper coefficient of discharge is less than the blast area of the fan, the pressure in the housing will equal that corresponding to the velocity of the tips of the blades, and the volume of discharge will be less than the capacity of the fan.

"When the area of the outlet multiplied by its coefficient of discharge is greater than the blast area, the volume of discharge will be greater than the capacity of the fan, and the velocity of the gas as it enters the inlet must be greater than the speed of the inner edges of the blades. Consequently, the pressure in the housing will be less than that corresponding to the speed of the tips of the blades."

Work Required to Move a Volume of Gas

"A fan operating against 1 oz. of pressure per square inch and discharging the gas through an orifice having 100 sq. in. performs work which may be calculated in the following manner:

"The total pressure against the fan is 100 sq. in. times the coefficient of efflux (say 0.75) times 1 oz., or 75 oz. or 4.7 lb.

"Assuming that the gas is air, then from the formula for velocity of dry air at 50° F. the air will have a theoretical discharge velocity through the blast area of 5,162 ft. per minute.

"The effective work is, therefore, $5,162 \times 4.7$ or 24,250 ft.-lb. per minute or 0.735 h.p. The actual work of driving the fan is greater than this result by the amount of work required to overcome the mechanical resistance and losses in the fan. This resistance is made up of the losses due to friction, windage and leakage. If these losses aggregate as much as the network then the power to drive the fan would be twice the network, *i.e.*, the efficiency of the fan as a machine would be 50 per cent. The actual power required

to drive the fan would be $\frac{0.735}{0.50} = 1.47$ h.p.

“Placing the above in form of formulæ and taking p in ounces per square inch,

$$\text{Useful work} = Pv = \frac{apv}{16} \text{ ft. lbs. per sec.}$$

$$\text{Since } P = \frac{ap}{16}$$

$$\text{From previous formula } v^2 = 18 g \frac{p}{d} \text{ or } p = \frac{dv^2}{18g}$$

$$\text{Therefore useful work} = \frac{adv^3}{288g} \text{ ft. lbs. per sec.}$$

“When p is given in inches of water

$$\text{Useful work} = Pv = \frac{5.2apv}{144} \text{ ft. lbs. per sec.}$$

$$\text{Since } P = \frac{a}{144} \times \frac{62.4}{12} \times p = \frac{5.2ap}{144}$$

$$\text{From previous formula } v^2 = 10.4 g \frac{p}{d}, \text{ or } p = \frac{dv^2}{10.4g}$$

$$\text{Therefore useful work} = \frac{5.2adv^3}{144 \times 10.4g} = \frac{adv^3}{288g} \text{ ft. lbs. per sec.}$$

“In these formulæ, av is proportional to the volume of gas discharged by the fan. Since a is in square inches, the volume of cubic feet per second will be

$$Q = \frac{av}{144}$$

“Representing the efficiency by E the work to drive the fan may be expressed as $\frac{adv^3}{288Eg}$ ft. lbs. per sec.

“From these formulæ it will be seen that the power varies as the cube of the gas velocity, while the pressure varies as the square of the velocity and the volume directly as the velocity.

“From a consideration of these factors it is evident that fans are more economical when used to move large volumes of gas at low pressure than small volumes at high pressure. For this reason fans are not economical machines for compressing gases. In addition to the above, fans always have a clearance space between the revolving wheel and its housing, through which space the gases have a tendency when under pressure to leak backward, which tendency we have seen increases as the square root of the pressure. Fans are seldom used for pressures exceeding about 10 oz., when higher pressures are desired the positive blowers are more efficient and are used

for pressures as high as 8 lb. When still higher pressures are desired, compressors or blowing engines, such as described later should be used.

"In the formula above the value of v is that due to velocity head. When the dynamic head is known, that is the velocity head plus the friction or static head, a simple formula for brake horse-power to drive the fan is:

"When p is given in ounces per square inch

$$\text{brake h.p.} = \frac{Q \times 9 p}{550 \times E}$$

"When p is given in inches of water

$$\text{brake h.p.} = \frac{Q \times 5.2 p}{550 \times E}$$

Design of Fans

"It must be evident that unless a fan is properly designed for the work which it has to perform, there will be considerable loss in power required to drive it.

"The peripheral speed of a fan must be such as to create the desired pressure. The pressure against which the fan has to operate is first determined, and having settled on the pressure the peripheral speed is made to conform with it.

"Furthermore, if the fan be direct connected either to an engine or to a motor, the speed of the fan will have to conform to that of the prime mover.

"The work formulæ given above are all based on the blast area of the fan. The way in which these formulæ will apply to the different types of fans will be made clearer under 'Description of Fans.'

"For any size of centrifugal fan there exists a certain maximum area over which a given pressure may be maintained, depending upon and proportional to the speed at which the fan is operated. If this area, sometimes called the 'capacity area,' 'blast area' or 'effective area of discharge' be increased, the pressure is lower while the volume is increased. Contrariwise, if this area be decreased, the pressure remains constant while the volume is increased. In practice the outlet of a fan rarely exceeds the 'blast area.'"

Description of Fans

"A disc, radial or propeller wheel fan consists of a machine having blades so mounted on an axle or shaft that when the shaft revolves these blades operate like a screw, and the gas is impelled forward in the direction of the axis.

"The blades may be straight and flat or curved. The blades may be curved in different ways so as to increase the screw effect and

diminish the centrifugal effect. Disc fans with curved blades will operate against slightly higher pressures and deliver more gas than those with straight blades.

“As the gas enters the fan it will be forced forward with some centrifugal effect; and this centrifugal effect can be somewhat reduced by having the blades revolve inside of a tube so as to prevent the gas from escaping over the outer edges of the blades.

“Disc fans will not operate economically against a pressure, as the pressure will increase the slip and the leakage of the air from the blades at the tip. If the pressure is at all high the gas will be drawn backward near the axis and will be blown forward near the outer tips of the blades, or in other words, the fan disc will simply circulate the air without making any delivery.

“Disc fans operate best when drawing gas from a practically free suction and discharging it at no pressure. When these fans are set up care must be taken that they do not operate against the wind, as the wind pressure will vitiate the operation of delivery.

“The number of blades appear to have a small effect upon the discharge, provided, of course, that the number is neither too large nor too small. Too many blades will simply churn the air and produce the effect of cavitation. Too few blades will not give a sufficient grip on the air to force it forward with the proper delivery.

“The gas delivered by a disc fan is very irregular in velocity. If anemometer readings are taken at different points in front of the disc, the recorded velocities will be found to vary without apparent reason, and the variation will not remain constant. It is, therefore, very hard to determine the mean velocity of discharge of the gas.

“The number of revolutions is limited by the strength of the fan and by the fact that a high velocity will cause the fan to hum and be noisy. The revolutions are usually limited so that the velocity at the tips of the blades shall not exceed 8,500 ft. per minute. (For noiseless operation, 4,000. Usual maximum 7,000). On this assumption, if D denotes the diameter of a fan in inches and

n denotes the number of revolutions per minute.

Then
$$\frac{\pi Dn}{12} = 8,500 \text{ and } Dn = 32,000 \text{ (nearly).}$$

“This last equation may be used to determine the limiting revolutions or diameter by assuming one or the other.

“The volume of gases discharged by a disc fan with a free suction and discharge can be estimated from the formula:

$$Q = \frac{1}{4} \pi \frac{D^2}{144} v \text{ in which } v = 0.39V$$

“The brake horse-power for the fan with the above value of Q can be estimated from the formula:

$$\text{Brake horse-power} = \frac{Q \times d \times v^{3/2}}{550 \times 2g} \times 13.5 \quad \left(\begin{array}{l} 13.5 \text{ is a constant} \\ \text{found from experience} \end{array} \right)$$

“When a disc fan operates against a pressure, *i.e.*, not with a free suction and discharge the above formulæ must be changed as Q becomes less because the slip becomes greater.

“Approximately $Q = 1/4\pi \left(\frac{D}{12}\right)^2 v^1$ in which v^1 equals 1.25 v less 45 per cent. of the theoretical velocity due to the pressure against which the fan is working.

“The brake horse-power will be the same as if the fan were working without restriction, although the volume of discharge Q will be less.

“Example: Free suction and discharge. Fan wheel 48 in. in diameter running at 450 revolutions per minute. Find Q and brake horse-power. Dry air at 50° F.

$$v = 0.39 \times 3.14 \times \frac{48}{12} \times \frac{450}{60} = 36.8$$

$$Q = 1/4 \times 3.14 \times \left(\frac{48}{12}\right)^2 \times 36.8 = 462$$

$$\text{Brake horse-power} = \frac{462 \times 0.077884 \times 36.8^{3/2} \times 13.5}{550 \times 64.32} = 3.07$$

“Also restricted discharge. Find Q and brake horse-power for the same fan and conditions when operating at 5/8 in. of water pressure.

“The velocity due to 5/8-in. water pressure is 51.8 ft. per second.

$$v^1 = 1.25 \times 36.8 - 0.45 \times 51.8 = 22.8$$

$$Q = 1/4 \times 3.14 \times \left(\frac{48}{12}\right)^2 \times 22.8 = 286$$

“The brake horse-power would be 3.07 because it is approximately the same as if the fan were working unrestricted. It is found by substituting the unrestricted value of Q instead of the actual restricted value.

“**Centrifugal Fans.**—Centrifugal fans operate on the principle of the vortex. They suck the gas in and discharge it off the periphery of the wheel by centrifugal action.

“**Fan Blast or Steel Plate Machine.**—The fan wheel consists of an axle or shaft on which are mounted radial arms carrying floats or blades. Each blade is narrower across the tip than it is across the

body. The blades are mounted inside of side plates, so that the gas is confined in the spaces between the blades, which thus form passages from the suction to the discharge side of the fan. These side plates also prevent the loss of friction between the revolving air and the sides of the housing.

"Sometimes the blades are curved backward at the tips so as to make the fan run more quietly, and sometimes the blades are curved backward for their whole depth so that the gas may enter the wheel and pass through it without shock.

"When fan wheels have flat blades, they can be run equally well in either direction, but when the blades are curved, the wheels should revolve with the convex sides of the blades in advance.

"When these fans are used for blowers, there is usually an inlet on both sides of the housing; and when used as exhausters, usually an inlet on one side only, as it facilitates the connection with the suction duct.

"The diameter of inlet is generally 0.6 or 0.7 of the diameter of the fan wheel.

"For high efficiency the area of inlet should not exceed 40 per cent. of the disc area of the wheel. The full width of the blades is generally made either one-half or three-eighths of the diameter of the wheel. The blades are generally cut off at the upper outer corners so as to taper at the tips at an angle of about 20 degrees with the side edges, but their width at the periphery should be not less than 0.6 to 0.7 of the width at the root, *i.e.*, not less than their maximum width times the same ratio as was chosen with the ratio of inlet to wheel diameter. Usually $w = 0.4 D$ and $w = 0.5 D$ (see Fig. 27).

"The width of the fan is made such as to provide the proper area for the flow of the gases through it so as to discharge the required volume. If the diameter of the fan wheel is made too small, it may not be possible to give the wheel sufficient width to permit the necessary discharge of volume, unless the fan is run at a very high rate of speed. This increased speed will result in raising the pressure above that required, and will, therefore, increase the power

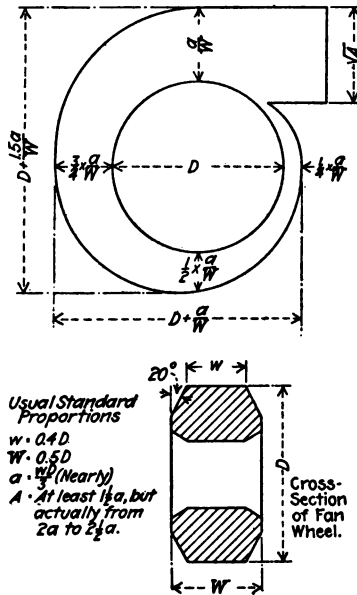

FIG. 27.—Steel plate fans.

necessary to drive the fan. Contrariwise, if the wheel be given a large diameter it may have to be made so narrow, in order to discharge the required volume, as to become impracticable. It will, therefore, be seen that under any given conditions there will probably be one diameter and width which will be best suited for the work.

"The blades of this type of fan are given sufficient depth so as to project inside of the circle of the inlet in order that they may better grip the incoming gas and force it through the wheel.

"With a peripheral discharge fan enclosed in a housing, the limit of its capacity to maintain a given pressure is measured by its blast area. In other words the velocity of discharge will be approximately equal to the peripheral speed of the fan, and the volume will be measured by this velocity times the blast area.

"If the blast area be increased the pressure will be less, and if the blast area be decreased the pressure will remain the same. For a peripheral discharge fan with a housing the blast area can be calculated as follows:

Let D denote diameter of fan wheel in inches;

w denote width of fan wheel at periphery in inches;

c denote a constant, depending upon the design of the fan and its housing, but which has a value not far from 2 1/2 to 3;

a denote the blast area in square inches.

$$\text{Blast area} = a = \frac{wD}{c} = \frac{wD}{2.6} \text{ (nearly).}$$

"If the shape of the discharge orifice and duct be known, and the coefficient of contraction determined, the area of the discharge orifice would be the blast area, as determined from the above formula multiplied by the reciprocal of the coefficient of contraction.

"The usual maximum peripheral velocity for standard fans is 6,600 (for noiseless operation about 4,200) ft. per minute, but should not exceed 8,000 ft. per minute. This latter figure limits the pressure to 1 3/4 oz. per square inch but special fans may be designed to maintain a pressure as high as about 12 oz.

"The volume past the blast area is about 86 per cent. of the peripheral speed. In other words, the peripheral speed must be 1.16 times the velocity due to the pressure of $V = 1.16 v$.

$$\text{Therefore} \quad n = \frac{V}{\text{wheel circumference}}$$

"The efficiencies without prime movers vary from 45 to 50 per cent. for commercial sizes when using dynamic head, or from 30 to 35

per cent. when using velocity lead. The outlet is generally made square, and its area is usually about two and one-half times the blast area, or $A = 2 \frac{1}{2} a$, but never less than $1 \frac{1}{2} a$.

"This proportioning will make the bottom of the outlet below the periphery of the wheel. The efficiency of commercial sizes is about 45 to 50 per cent. without a prime mover. If the prime mover efficiency is taken at 85 to 90 per cent. then the total efficiency of the fan and prime mover would be between 38 and 45 per cent.

Example:

"Given the quantity of air per minute, 65,000 cu. ft., the temperature of dry air 70° F. and the pressure $1 \frac{3}{4}$ in. of water. Determine the diameter of fan, revolutions and brake horse-power.

Under these conditions the density of the gas or its weight per cubic foot may be taken as 0.0754 lbs.

$$v = \sqrt{\frac{136036.8 \times 1.75}{(406.7 + 1.75) \times 0.0754}} = 88.0$$

$$\frac{65000}{60} = \frac{a \times 88.0}{144} \quad \text{Therefore } a = \frac{65000 \times 144}{60 \times 88.0} = 1,770$$

Making $w = 0.4D$

$$1,770 = \frac{0.4D^2}{2.6}, \quad D^2 = 11,500, \quad D = 107$$

$$V = 1.16 \times 88.0 = 102$$

$$\text{Wheel circumference} = \frac{107}{12} \times 3.14 = 27.9 \text{ ft.}$$

$$\text{Therefore } n = \frac{60 \times 102}{27.9} = 220$$

With E as 45 per cent. the power to drive the fan is

$$\text{Brake horse-power} = \frac{1770 \times 0.0754 \times 88^3}{550 \times 288 \times 32.16 \times 0.45} = 40$$

"**Housing.**—The housing is placed around the wheel in an eccentric position and has a form approaching the spiral. This arrangement facilitates the gas delivery from the wheel. The openings for discharge of the gas are tangential to the wheel. There may be one or more openings as circumstances demand but their combined area of discharge should not exceed the fan capacity. It makes no difference whether these discharge outlets are placed horizontally or vertically.

"The arrangement of discharge outlet, however, gives a name to the fan—as a horizontal top discharge, a vertical discharge, a hori-

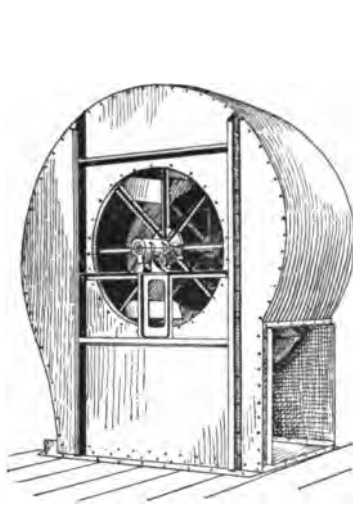

FIG. 28.—Full housed steel plate fan. Left-hand bottom horizontal discharge.

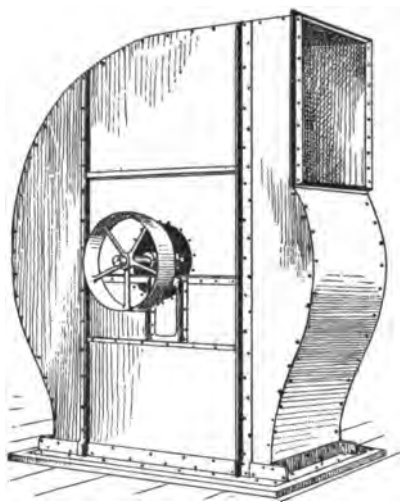

FIG. 29.—Full housed steel plate fan. Right-hand top horizontal discharge.

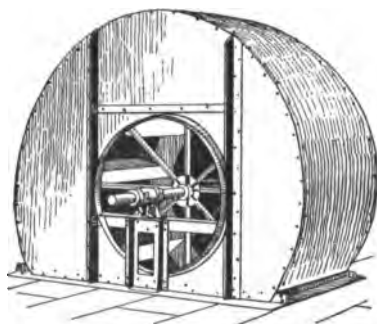

FIG. 30.—Three-quarter housed steel plate fan. Right-hand bottom horizontal discharge.

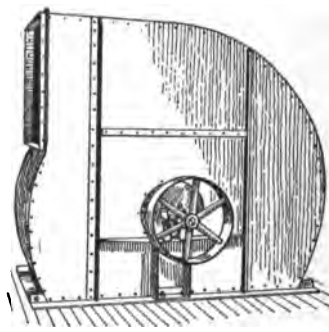

FIG. 31.—Three-quarter housed steel plate fan. Left-hand top horizontal discharge.

zontal bottom discharge, a double discharge, etc. (Figs. 28, 29, 30, 31 and 32.)

“The spiral or scroll form of the casing should be such as to let the gas escape with freedom from all parts of the periphery. The smaller diameter of the scroll should not be less than $D + \frac{a}{W}$ and the larger diameter not less than $D + \frac{1.5 a}{W}$ in which

D denotes the diameter of the wheel in inches;

a denotes the blast area in square inches;

W denotes the maximum width of blades in inches.

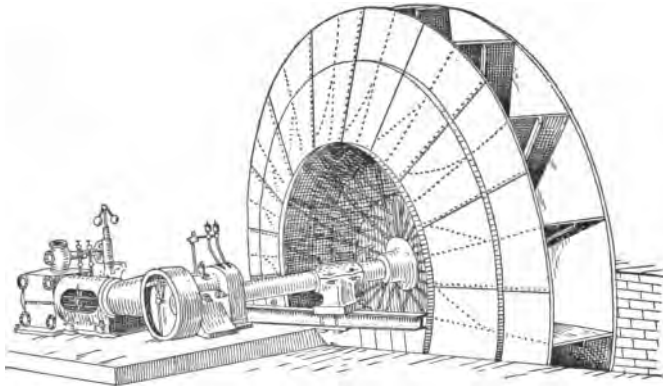

FIG. 32.—Allis Chalmers steel ventilating fan.

“**Cone Wheel Fans.**—The cone wheel fan is a single inlet peripheral discharge fan. It is used both with and without a housing. Cone wheel fans are not efficient for use against pressures in excess of 1 oz. per square inch and are seldom used against pressures as high as this limit. Generally speaking, they are not as economical in the handling of gases as centrifugal fan-blast machinery properly encased in a well-designed close-fitting housing.

“Cone wheels should have a perfectly free inlet and be arranged to have a free discharge of air from all points of the periphery. When cone wheels are encased in a housing the housing is usually much larger than the fan wheel to permit a perfectly free and unrestricted discharge. As ordinarily arranged, the inlet to a cone wheel is a hole in a wall of the apartment from which the gas is to be sucked-(Figs. 33 and 34).

“On the axle or shaft of the fan there is mounted a cone with its apex turned toward the inlet. Between the cone and the periphery of the wheel there are blades or floats, and these blades are encased

inside of side plates. As the air enters the inlet it is deflected by the cone to the floats, which together with the side plates, continue to change the direction of the air so that it is discharged off the periphery in a plane at right angles to the shaft or line of entrance. The width of cone wheels is generally one-quarter the diameter of the wheel, and the inlet opening is generally three-quarters of the diameter of the wheel. The floats are curved backward and tapered

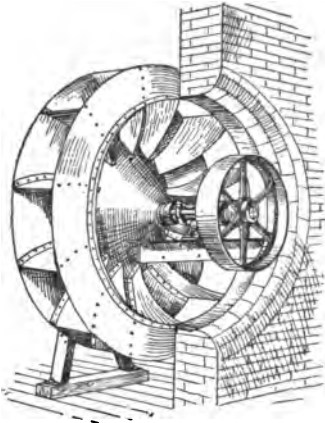

FIG. 33.—Cone fan inlet side.

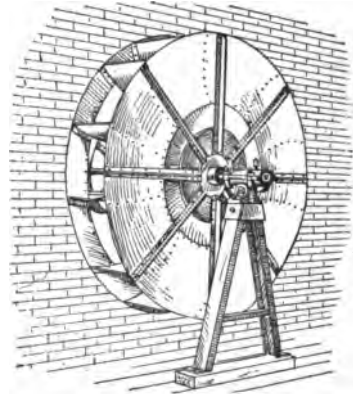

FIG. 34.—Cone fan discharge side.

toward the periphery so that they have a width at the tips of about three-quarters the width of the wheel.

“Assuming that the air is discharged at a velocity equal to the speed of the tips of the floats, the capacity of a properly designed cone wheel in cubic feet per second is approximately:

$$Q = 6.4D^2\sqrt{p}$$

for exhausting and $Q = 5.0D^2\sqrt{p}$ for blowing in which

D denotes the diameter of the wheel in inches and

p denotes the pressure in ounces per square inch corre-

sponding to the velocity of the tips of the blades.

“The horse-power required to operate a cone wheel including efficiency is approximately brake horse-power = $\frac{Qp}{43}$ for exhausting and

$$\text{brake horse-power} = \frac{Qp}{22} \text{ for blowing.}$$

“The limits of peripheral speed are about the same as for a disc fan so that assuming the speed of the tips of the blades, the revolutions and diameter can be calculated by assuming one or the other as with disc fans.

“**Turbine Blast or ‘Sirocco’ Fan.**—The name Sirocco is a trade name. These fans are centrifugal in their action and have a peripheral discharge. The runner or blast wheel is built up of steel, and consists essentially of three parts—the interior cone to deflect and turn the air as it enters the inlet toward the blades, the blades, and the side plates. The runner is shaped like a drum. The blades are long and narrow radially, being generally between six and nine times as long as they are wide. The runners are usually equipped with about 64 blades. The blades are curved so that the concave side revolves forward. The blades are not quite as deep as the side plates, and the side plates are made one-sixteenth the diameter of the wheel.

“These fans are usually made with the inlet on one side only, the other side being closed by the back of the internal cone. When double inlets are desired, two internal cones are placed back to back, and this practically means that the wheel is made double.

“The peripheral speed at which these fans can be run before they begin to hum or become noisy is higher than that of the steel plate fan. With ordinary sizes they remain quiet until peripheral speeds of 10,000 ft. per minute are reached, but a peripheral speed of over 15,000 ft. per minute is often used.

“The design of these fans is quite different from that of a steel plate fan. Having the blades curved forward, which is quite correct in principle, results in an increase in the velocity of discharge, which with properly shaped blades, is twice that of the “steel plate” fan. In other words, the velocity of discharge from a properly designed turbine fan, is theoretically twice that of the peripheral speed, and actually about 117 per cent. of the peripheral speed. As these fans are made about twice as wide as the steel plate fan, and as the velocity of discharge is twice as great, a turbine fan wheel will discharge about four times the volume of gas as a steel plate fan of equal diameter and run at equal speed.

“These fans are mounted in a housing, and the ratio of outlet to inlet is one to two. There are three types of these fan wheels which are distinguished by the manner in which they are bladed (Fig. 35).

- (a) In the forward inclined wheel the blades are curved forward of the radii.
- (b) In the radially inclined wheel, the blades are curved on the radii.
- (c) In the backward inclined wheel, the blades are curved behind the radii.

“These different forms rank in the order of mechanical efficiency as given above, and in the matter of speed of revolutions in the reverse order. Owing to the high speed at which these turbine fans can be run they are well adapted for direct connection to high-speed prime movers (Fig. 36).

“The commercial efficiencies when used for blowing are about 59 per cent. for forward blades, 53 per cent. for radial blades and 50 per cent. for backward blades.

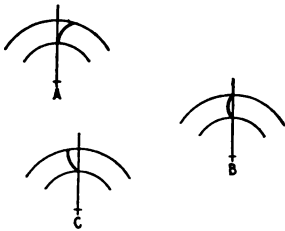

FIG. 35.—Three types of blading.

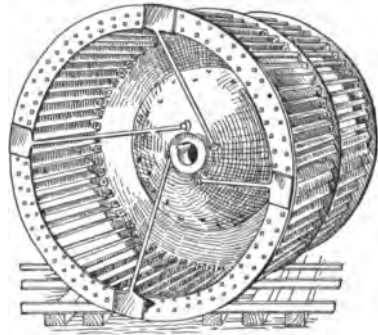

FIG. 36.—Sirocco double inlet runner.

“The width of the runner is made two-thirds the diameter for standard sizes.

“The volume of discharge can be calculated from the formula

$$Q = \frac{av}{1.44}, \text{ in which } v = V \times 1.44$$

$$a = \frac{wD}{27.5} = \frac{2/3D^2}{27.5} = \frac{2D^2}{82.5}$$

“When the dynamic head is known the same formula for power required can be applied to this fan as to others.”

CHAPTER VII

PISTON COMPRESSORS

In the practical applications of air for power and other purposes, the simplest method of compressing air above those pressures for which the fan and positive pressure blower are particularly adapted is by means of a piston compressor.

This method of compression is used more than any other method and for that reason considerable attention will be given to it. Fig. 37 shows in cross-section such a compressor, its piston, piston-rod

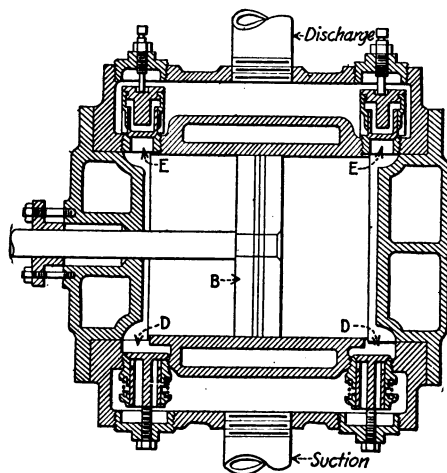

FIG. 37.—Cross section of piston compressor.

and valves. *D* represents the inlet valve through which the “free air” is drawn into the compressor, and *E* the outlet or discharge valves through which the compressed air is discharged into a reservoir or receiver as it is quite commonly called.

Naturally with this type of compressor the piston movement is limited, so that at its extreme positions the piston will not strike the cylinder ends or heads. That volume of the cylinder through which the piston does not move, together with the volume occupied

by the passages leading from the cylinder to the valves, is called the clearance.

Action of Piston Compressor.—Suppose the piston is to start at the right end of its stroke. As it moves to the left, a slight vacuum will be created in the cylinder on the right side of the piston and valve *D* will be opened. Free air will rush in, following the movement of the piston and filling the cylinder. As the piston starts to the right, this same operation will take place on the left side of the piston, while on the right compression will commence as the volume occupied by the air in that part of the cylinder is reduced.

If the valve *E* is in communication with a reservoir of compressed air at 30-lb. gage pressure, no air can escape from the cylinder until the pressure has risen to a little above 30 lb. When this is done the valve *E* will be lifted from its seat and the compressed air will be pushed bodily out of the cylinder into the reservoir.

At the end of the stroke, the clearance volume will be filled with this compressed air and as the piston starts back valve *E* will close and the compressed air in the clearance space will expand to fill the gradually increasing volume in the cylinder and will continue to do so until the pressure in the cylinder is lower than that of the atmosphere, when valve *D* will open and a new supply of free air be drawn in. *The clearance space reduces the volume of free air drawn into the compressor.*

Indicator Card of Piston Compressor.—These changes are shown by the indicator card given in Fig. 38, which shows the changes in

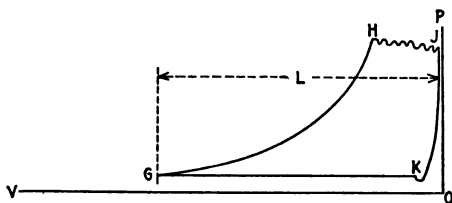

FIG. 38.—Indicator card of piston compressor.

pressure and volume taking place on one side of the piston. The distance *L* represents the volume displaced by the piston during one stroke. Starting with the piston at *G* and the cylinder full of air, the pressure of the confined air will gradually rise as the volume is being reduced by the moving piston until a pressure *H*, a little above the pressure in the reservoir is reached. From here until

the end of the stroke the piston will force the compressed air out of the cylinder into the reservoir. The wavy line $H-J$ represents this expulsion, the inertia of the moving parts of the indicator and the fluttering of the discharge valve on its seat causing the irregularities of this discharge line. When the stroke is completed the pressure of the air in the reservoir closes the valve E , leaving the clearance space full of compressed air at the high pressure J . As the piston moves to the left the compressed air in this clearance space will expand to fill the constantly increasing volume until a pressure a little below that of the atmosphere is reached (K), when valve D will open and free air rush in to fill the cylinder as the piston continues its movement.

The more air in the clearance space the further will the piston B have to move before the compressed air in the clearance space can have the opportunity to expand low enough to open the inlet valve. For this reason the clearance space for a piston air compressor is made as small as possible.

Effect of Clearance.—The loss due to clearance is not a loss of power, for most of the energy used in compressing the air into the clearance space is given back in expanding and helping to move the piston. The only loss in power is the heat loss through radiation. The loss due to clearance is mainly a loss of capacity which, in many cases, is a rather serious matter. Engineers have sought to reduce this to a minimum with the result that the clearance volume of a modern piston air compressor varies from 0.02 to 0.0094 of the volume of the piston displacement.

Methods of Reducing Clearance.—Various methods have been devised to reduce this clearance, some even going to the extent of putting in spring heads on the cylinder which the piston could strike at each end of the stroke without serious injury. This method, however, introduces complications that are not always desirable.

Another method of reducing the clearance loss that has been suggested is to let the piston uncover a passage leading from the clearance space just at the end of the stroke, and thus allow the compressed air in the clearance space to expand into the cylinder on the other side of the piston, as shown by Fig. 39, without reducing the capacity of the compressor. This, however, is open to the

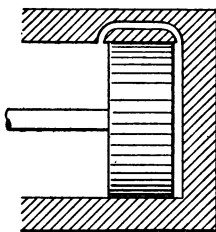

FIG. 39.—Uncovering port to release clearance pressure.

objection that the compressed air in the clearance space, which normally acts as a spring, is released and the piston will pound at the end of each stroke unless some other means is used to prevent it.

Some piston air compressors are so designed that when the machine is cold the piston will almost touch the cylinder-head when at the crank end of its stroke. As the compressor is operated the heat of the air being compressed will be partly transmitted to the piston-rod and cause it to expand slightly, thus increasing

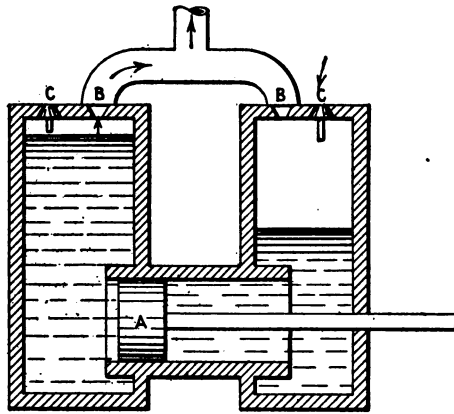

FIG. 40.—Hydraulic piston compressor.

the crank-end clearance and decreasing the head-end clearance, and by designing the compressor so that when hot, the piston will just miss touching the cylinder-head when at head-end dead-center, and when cold just miss the other cylinder-head when at dead-center, the clearance volume of the cylinder is reduced to a minimum.

Some of the early air compressors were built, as indicated by Fig. 40, so as to reduce the clearance volume by using a water column as a piston. As the piston *A* is moved back and forth the water column in each upright cylinder is caused to alternately rise and fall. As it falls, valve *C* is opened and free air rushed in. As the water column is raised, valve *C* is closed and the confined air is compressed to a pressure sufficient to open valve *B* and permit the compressed air to escape to a reservoir. The water at its upper height can fill the entire space, including the passage to the valves, which a metal piston could not do, so the clearance is in this way reduced to a minimum. This type of compressor was practically

abandoned, but its principle has been recently revived in air compressors working on the principle of the Humphrey pump.

Suction Line.—If in the design of a piston compressor the inlet valve or the passages for the same should be too small, then the air cannot rush in as fast as the piston moves and the suction line, instead of being straight, will fall below the horizontal, to rise again near the end of the stroke as the piston velocity decreases.

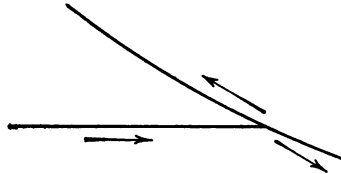

FIG. 41.—Effect of early closing of inlet valve.

A suction line that is not horizontal indicates restricted inlet for admission of air.

It may sometimes happen that as the piston, which has its maximum velocity near the middle of the stroke, nears the end with a decreasing speed, the inlet valve will close before the end of the stroke is reached, and the admission line will fall slightly. As compression starts, this line will be retraced until a pressure greater than the admission pressure is reached, as shown by Fig. 41. A good indicator card for a piston air compressor will have the compression line start very close to the end, as shown by Fig. 38.

Compression Line.—One reason for the ideal method of air compression being isothermal, as already explained, is because

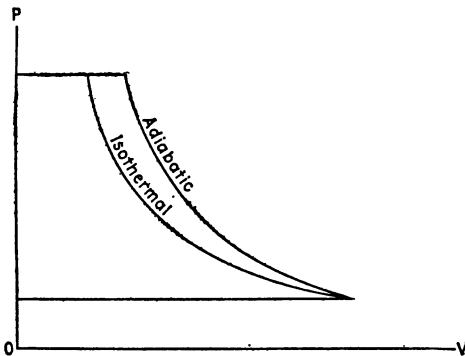

FIG. 42.—Card showing isothermal and adiabatic compression.

any energy stored as heat in the compressed air above the temperature of the surrounding atmosphere will soon be radiated and hence lost. Another reason, as shown by the chart, Fig. 11, is that if the compression is not isothermal, the pressure due to the increased tempera-

ture will rise above that which would result from isothermal compression and hence cause an increased expenditure of energy to operate the compressor, as shown in Fig. 42. This increased expenditure of power may be avoided by isothermal compression

The approximate horse-power required to compress air under isothermal or adiabatic conditions may be determined as indicated by the formulæ in Chapter IV. This has been done for various pressures indicated in Table IX, which will give an idea of the saving to be secured from isothermal compression.

TABLE IX

Gage pressure, pounds	Atmospheres absolute or ratio of compression	Single-stage compression, from atmospheric pressure at sea-level. Initial temperature, 60° F. Horse-power required to compress 1 cu. ft. of free air			
		Calculated horse-power		Actual horse-power (approx.)	
		Isothermal compression	Adiabatic compression	Allowance for losses above adiabatic compression, 15 per cent.	Allowance for losses above adiabatic compression, 20 per cent.
20	2.36	0.0551	0.0626	0.0720	0.0751
25	2.71	0.0637	0.0741	0.0852	0.0890
30	3.04	0.0713	0.0843	0.0970	0.1011
35	3.38	0.0782	0.0941	0.1082	0.1129
40	3.72	0.0842	0.1029	0.1183	0.1234
45	4.06	0.0895	0.1115	0.1282	0.1338
50	4.40	0.0950	0.1191	0.1370	0.1430
55	4.74	0.0994	0.1269	0.1460	0.1522
60	5.08	0.1041	0.1337	0.1537	0.1604
65	5.42	0.1081	0.1401	0.1610	0.1681
70	5.76	0.1123	0.1468	0.1690	0.1761
75	6.10	0.1162	0.1535	0.1765	0.1842
80	6.44	0.1195	0.1591	0.1830	0.1910
85	6.78	0.1224	0.1651	0.1900	0.1961
90	7.12	0.1256	0.1703	0.1955	0.2040
95	7.46	0.1287	0.1760	0.2024	0.2112
100	7.80	0.1315	0.1807	0.2080	0.2168
110	8.48	0.1366	0.1894	0.2180	0.2272
125	9.50	0.1442	0.2025	0.2328	0.2430

Wet and Dry Compression.—The two principal systems which have been used in attempting to secure isothermal compression in a

piston air compressor are the "wet system" and the "dry system." A wet compressor is one which introduces water directly into the cylinder during compression.

A dry compressor is one which admits no water to the air during compression but surrounds the cylinder with a jacket of circulating water in order to reduce the heat of compression.

There are two kinds of wet compressors: First, those which inject water in the form of a spray into the cylinder during compression; second, those which use a water piston in compressing the air, such as shown in Fig. 40.

Numerous tests have been made of these different methods of air compression showing that the compression can be brought closest to the ideal isothermal by means of injecting a spray of water directly into the cylinder during the compression.

Although the best results have been secured by the wet system of compression, still it has been practically abandoned in favor of a dry system of compression using a water-jacket, for the following reasons:

First. The mechanical difficulty of introducing the water in a fine enough spray to reduce the temperature of compression as it is being produced.

Second. Impurities in the water through mechanical and chemical action destroy the metallic surfaces of the cylinder and piston.

Third. Wear due to insufficient lubrication.

Fourth. Difficulty of regulating the amount of water to be introduced.

Fifth. Limitations of speed due to the presence of water.

Actual Compression.—If an isothermal and an adiabatic line be drawn on an indicator card taken from an actual modern air compressor starting at the point where compression begins, the actual compression line will come very close to the adiabatic.

If the compressor operates at a very slow speed, there is an opportunity for the heat that is generated by compression to be radiated and the compression line will come closer to the ideal isothermal.

That is, with a high-speed air compressor, the compression is approximately adiabatic, while with a slow-speed compressor with efficient water-jacket the compression line may approach the isothermal, speed being an important element in determining the slope of the compression line.

Cards from Air Compressors.—In taking indicator cards from an

air compressor all the precautions that are necessary for taking steam cards apply with equal force, as erroneous conclusions may be very easily drawn from the cards if care is not taken. For instance, if the piston of the air compressor leaks slightly, then the compression line will approach the ideal isothermal line, indicating a very desirable compression line, while in reality the compressor is defective. For this reason, extra precautions must be taken in order that the card may indicate the true state of affairs in the cylinder.

When air is compressed in a cylinder to a pressure of 100 lb. per square inch without cooling, temperatures ranging from 475° to 550° are reached, and these high temperatures are not only productive of poor economy and low efficiency but are dangerous because of the explosive nature of the compressed air containing the vapors of the cylinder oil used for lubricating the piston.

CHAPTER VIII

EFFICIENCIES AND ENERGY COMPENSATION

In the discussion of Chapter IV, clearance was disregarded, but in calculating the required dimensions of an air compressor the effect of clearance must be considered.

It is usual to express clearance as a certain percentage of the piston displacement. If this percentage expressed as a decimal fraction is represented by C , the volume occupied by the air to be compressed at the end of a suction stroke will be $(1+C)$ times the piston displacement.

Volumetric Efficiency.—The effect of clearance upon the capacity of a compressor is usually expressed in terms of the “volumetric

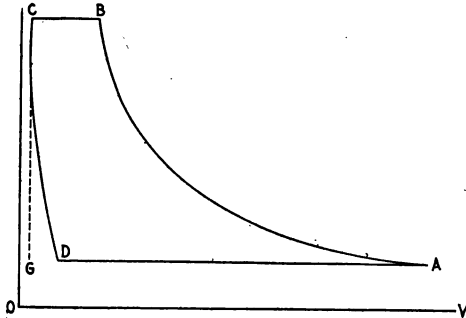

FIG. 43.—Ideal card for piston compressor.

efficiency,” but as this term is not always interpreted in the same way it is advisable to use two terms “apparent volumetric efficiency” and “real volumetric efficiency.”

Apparent Volumetric Efficiency.—The apparent volumetric efficiency is the apparent volume of free air drawn in as shown by the indicator card divided by the volume of the piston displacement, or it is $\frac{AD}{AG}$ of ideal card, Fig. 43. In an actual card, Fig. 44, this ratio is also shown by $\frac{AD}{AG}$.

In Fig. 43, the clearance line $C-D$ will follow the equation

$$p_c V_c^n = p_d V_d^n$$

but, as $V_c = C$, this may be written

$$p_c C^n = p_d V_d^n$$

from which

$$V_d = \left(\frac{p_c}{p_d} \right)^{\frac{1}{n}} C$$

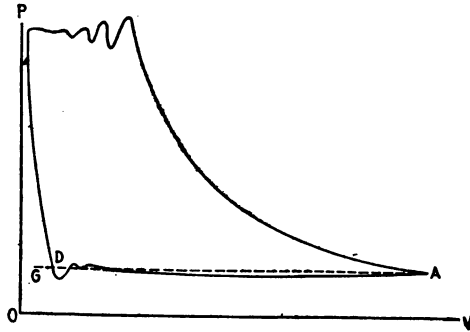

FIG. 44.—Actual card of piston compressor.

The apparent volumetric efficiency, or $\frac{AD}{AG}$, may be written

$$\frac{AG - DG}{AG}$$

or

$$1 - \frac{DG}{AG}$$

or

$$1 - \frac{V_d - C}{AG}$$

Calling the piston displacement AG unity, the apparent volumetric efficiency may be written

$$1 - C \left(\frac{p_c}{p_d} \right)^{\frac{1}{n}} + C, \text{ or } 1 - C \left[\left(\frac{p_c}{p_d} \right)^{\frac{1}{n}} - 1 \right]$$

The effect upon the capacity may be illustrated by assuming a compressor in which p_c is 80 lb. per square inch gage, or 94.7 lb. absolute, and C is 2 per cent and n is 1.4.

Substituting in the above,

$$1 - 0.02 \left[\left(\frac{94.7}{14.7} \right)^{\frac{1}{1.4}} - 1 \right] = 0.9444.$$

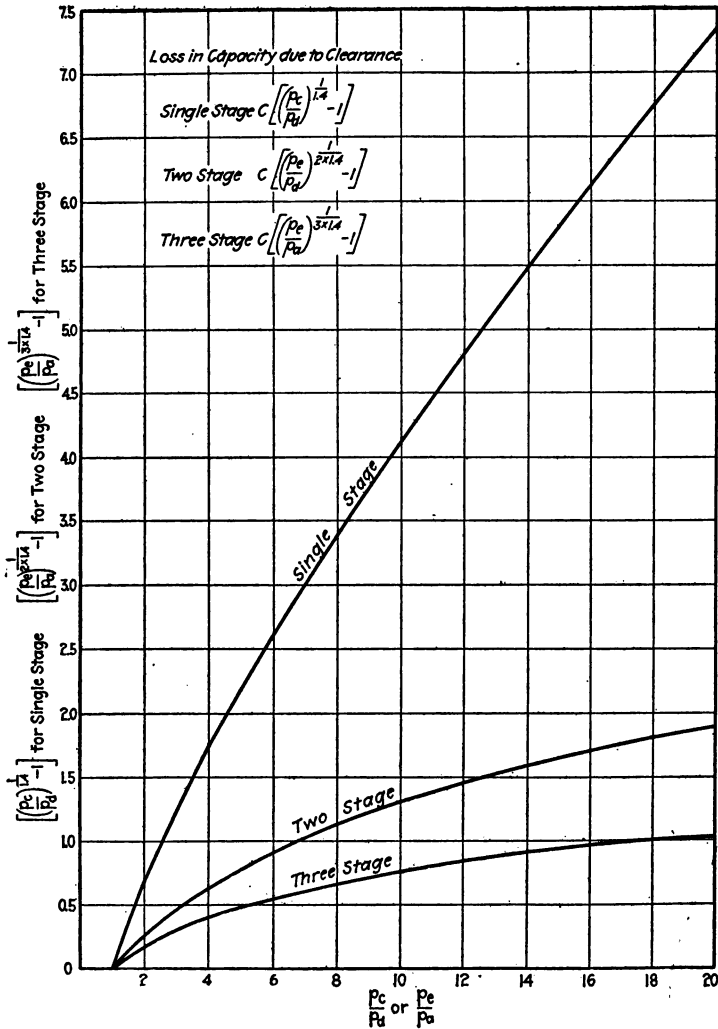

FIG. 45.—Loss of capacity due to clearance.

That is, such a compressor would only take in 94 per cent. of the piston displacement in free air, and poor valve action would reduce this capacity still further. The loss of capacity due to clearance for various pressure ratios is shown in Fig. 45.

True Volumetric Efficiency.—The above illustration would be true if the temperature of the air after being drawn into the cylinder were the same as the atmosphere, and the pressure at the instant of compression equal to the atmosphere. As this is seldom true, it is necessary to make correction for this by multiplying the above expression by

$$\frac{T_{am}}{T_1} \frac{P_1}{P_{am}},$$

in which the subscript *am* stands for atmospheric conditions and subscript 1 for conditions at the beginning of compression.

The *true* volumetric efficiency is the ratio of the free air actually drawn in to the piston displacement and is represented by the formula

$$\frac{T_{am}}{T_1} \frac{p_1}{p_{am}} \left[1 - C \left(\left[\frac{p_c}{p_d} \right]^{\frac{1}{n}} - 1 \right) \right]$$

Cylinder Efficiency.—The cylinder efficiency of an air compressor may be defined as the ratio of the work done in a complete cycle to

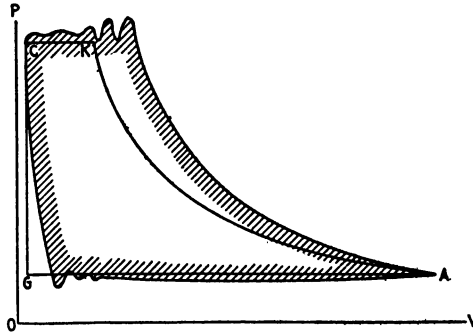

FIG. 46.—Cylinder efficiency.

compress isothermally a volume of air at atmospheric pressure equal to the intake piston displacement divided by the actual work done in the air cylinder.

This would be Fig. 46, the area *AKCG* divided by the shaded area, or the actual work done in the air cylinder.

Efficiency of Compression.—The efficiency of compression may be defined as the product of the cylinder efficiency and the true volumetric efficiency, or it is the work done in a complete cycle to compress isothermally, without clearance, a given volume of free air divided by the work actually expended in compressing the same volume of free air.

Mechanical Efficiency.—The mechanical efficiency of an air compressor is the work done in the air cylinders divided by the work done in the steam cylinders, if driven direct by steam, or in the gas-engine cylinders, if gas engines are used, or the work delivered at the belt if the compressor is belt driven.

Net Efficiency.—The net efficiency of a compressor unit driven by a steam engine or turbine direct is the ratio of the internal energy available in the compressed air at room temperature to the heat energy available in the steam supplied; or it is the energy available by adiabatic expansion of the compressed air at room temperature to atmospheric pressure divided by the energy available in the steam supplied, if expanded adiabatically in a Rankine cycle.

In considering efficiencies of air compressors, it is important to distinguish between a machine used for compressing air as a means of storing and transmitting mechanical energy, in which the ideal compression is isothermal, and a machine used for supplying air under pressure for purposes of combustion, as in forges, cupolas and blast furnaces. In these last cases the pressures are comparatively low and the resulting increase of temperature due to adiabatic compression is not objectionable. In fact there is ample justification for taking, in these cases, adiabatic compression as the standard.

Blower Efficiency.—Henry F. Schmidt in an article in the *Journal A. S. M. E.* of Nov., 1912, on "Centrifugal Blowers" indicates a "blower efficiency" for any blower *not water-jacketed*, by dividing the rise of temperature, as calculated from adiabatic compression from the suction to the discharge pressure, by the actual rise of temperature taking place during the compression in the blower.

The losses in a blower are principally friction, eddies and leakage. All energy losses reappear as heat and bring the temperature after compression higher than that due to adiabatic compression, and in the article the author proves that this ratio will reduce to the form $\frac{T_1 - T_2}{T_1' - T_2}$ in which T_2 is the initial temperature of the air, T_1' its actual final temperature, and T_1 the final temperature if the compression had been adiabatic. This formula is open to the criticism that the radiation is disregarded, but as its value is comparatively small the "blower efficiency" expression has the decided advantage of simplicity and ease of determination.

Economic Efficiency.—Franz zur Nedden in his articles on Turbo-blowers and Compressors in the *Engineering Magazine* for Nov., 1912, states that the thermic losses of a compressed gas may be

expressed by the contraction which it undergoes in cooling. In place of the larger volume of power medium which leaves the compressor, a diminished volume only at the same pressure reaches the destination. As in perfect gases contraction due to cooling is in direct proportion to the absolute temperature, the fraction formed by taking the absolute temperature of the atmosphere as the numerator and the absolute temperature of the air or gas leaving the compressor as the denominator, might be taken as a fair expression of the losses caused by the unutilized heating of the gas or air in the compressor.

As this loss would not occur if the gases were compressed isothermally it is debited entirely to the compressor. He cites in illustration a compressor of the piston type of 140,000 cu. ft. per hour capacity working against 115 lb. per square inch at 90 r.p.m., in which the temperature leaving the compressor was 197° F. and the temperature of the atmosphere 41° F., this gives an "economic efficiency" of $\frac{460+41}{460+197} = \frac{501}{657} = 76.1$ per cent.

Energy Compensation.—If an air compressor is driven direct by a steam engine with the steam and air cylinders tandem and one

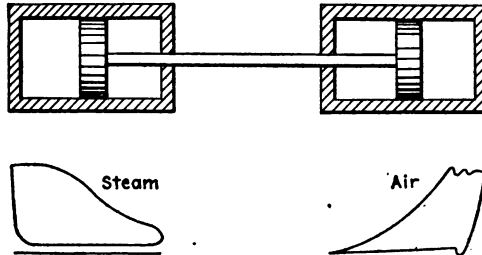

FIG. 47.—Direct acting steam compressor.

common piston-rod as shown in Fig. 47, with the valves arranged to give a steam and air card as shown, the greatest force is exerted on the piston-rod at the time when the least is required in the air cylinder and when the air cylinder needs the greatest force applied to expel the compressed air, the least is being applied in the steam cylinder.

Many ingenious contrivances have been devised for storing the excess energy developed in the steam cylinder during the beginning of the stroke and drawing on this excess during the last part of the stroke.

When a fly-wheel is used it must of necessity be very large in order to do this, as the amount of energy that can be stored in the fly-wheel will depend upon its weight and speed.

Hydraulic Compensator.—One form of energy compensator is shown in Fig. 48, which represents a sketch of a D'Auria non-rotative air compressor.

The desired result is obtained by using a "hydraulic compensator," which consists of a cylinder *A* fitted with a plunger *B* carried by the same piston-rod that connects the steam and air piston. The ends of the compensator cylinder communicate with each other by

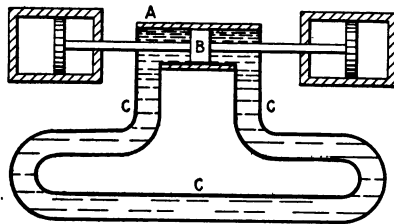

FIG. 48.—D'Auria System of energy compensation.

means of a loop of pipe *c-c-c* so constructed as to form a very rigid bed-plate for the machine, a very desirable feature, as it helps to keep the machine in alignment. The cylinder and pipe are filled with water, or any other liquid, leakage being made up through a pipe.

When the compensator is in action, the liquid column contained in the compensator is moved reciprocally and as it requires energy to start a mass moving and also to stop it after it gets in motion, the excess energy of the steam cylinder is used up or rather stored in starting the liquid in motion during the first part of the stroke, and this excess energy is given back during the last part of the stroke as the pistons near the end of their stroke.

Lever Compensation.—Sometimes two steam air compressors are placed side by side and the piston-rods connected by a system of levers as shown in Fig. 49, so that the excess energy that is not needed in one air cylinder is conveyed by the system of levers to the other air compressor and aids that near the end of its stroke. By this arrangement one compressor supplements the other.

Weight Compensation.—A method adopted by the Norwalk Iron Works is best shown in their two-stage compressor, driven by a tandem compound steam engine, as shown in Fig. 50.

By arranging air and steam cylinders, as shown, with a common piston-rod, an excessively heavy moving piece is secured, which requires considerable energy to start in motion and also to bring to rest near the end of the stroke. That is, a large share of the energy

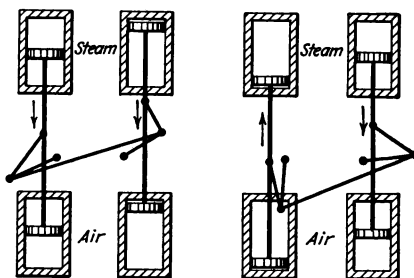

FIG. 49.—Lever system of energy compensation.

developed in the steam cylinder during the beginning of the stroke is used in starting this heavy piece in motion and the extra energy required in the air cylinders during the last part of the stroke is taken from this moving mass in bringing it to rest.

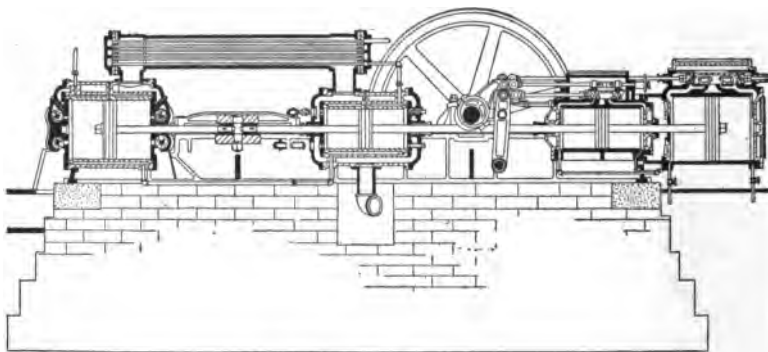

FIG. 50.—Norwalk compressor.

Straight-line Compressor.—The balance is aided still further by a fly-wheel which with shaft and eccentrics is used to operate the valves. It is evident that an air compressor which has the steam cylinder and the air cylinder on the same piston-rod will apply the power in the most direct manner and will involve the simplest mechanism in construction.

This type of compressor (Fig. 51) is usually referred to as a straight-line air compressor and is usually equipped with one or

two fly-wheels to act as energy compensators. Even then it is difficult to secure a very good economy, especially with light fly-wheels. In order to secure maximum economy of steam an early cut-off is desirable, but if no fly-wheels are used this cannot be obtained, and it is necessary to admit boiler steam for almost the entire stroke.

The air compressor used by the Westinghouse Air Brake Company in their familiar system of train brakes is of this type. It is admirably suited for this purpose because of its simplicity and the fact

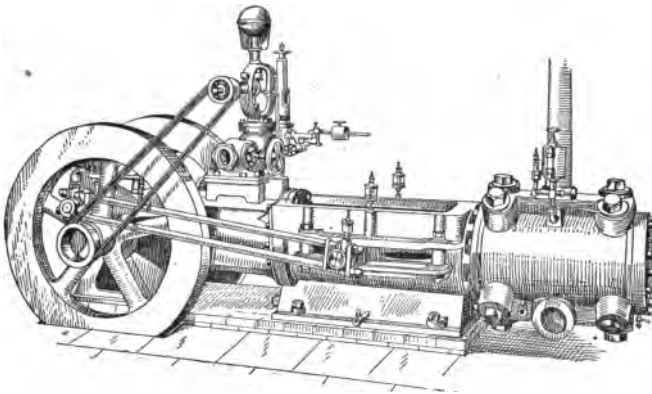

FIG. 51.—Straight-line air compressor.

that it does the most work when the engine is at rest or using only a portion of its steam, and for this reason it utilizes steam that might otherwise escape out of the safety valve.

Many efforts have been made to equalize the steam power and air resistance by using a crank shaft and placing the crank pins of the steam and air-connecting rods at an angle with each other so that the greatest force would be exerted in the steam cylinder at the time the greatest resistance was being encountered in the air cylinder. The same thing may also be accomplished by placing the cylinders at an angle with each other. Various compressors have been built on this principle, the angle between the cylinders varying in different designs, being in some 45 degrees, in others 90 degrees, and in still others 135 degrees. The best results, however, have been secured with an angle of 90 degrees.

This arrangement has been adopted by some manufacturers of compressors for refrigerating plants, but has not been used by manufacturers of air compressors to any extent. Fig. 52 may make

this clearer, with the horizontal cylinder for steam and the vertical one for the ammonia compressor. When the steam piston is at dead center the air piston has completed about half its stroke, and the high steam pressure admitted to the steam cylinder during the first part of the stroke will be available for moving the compressor piston through the last half of its stroke when the greatest resistance is encountered. As the steam piston is completing the last half of its stroke, the compressor piston starts down compressing a new supply of free air on its lower side if of the double acting type, and as the work of the first half of the stroke of the air piston is com-

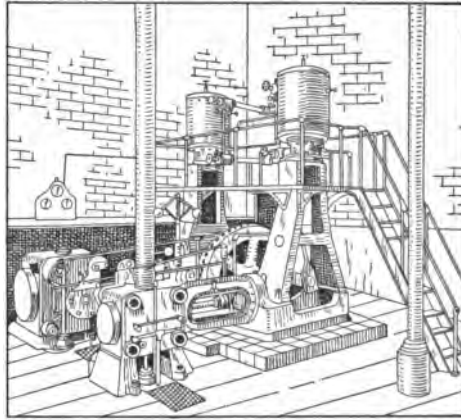

FIG. 52.—Horizontal-vertical arrangement of cylinders.

paratively slight, the pressure in the steam cylinder can be reduced for the last half of its stroke, giving both economy of steam and uniformity of speed.

Duplex Compressor.—More frequently this result is accomplished by placing the two cylinders in a horizontal plane with the crank pins at an angle of 90 degrees as shown by Fig. 53. This arrangement is frequently adopted when air compressors are driven by gas engines and if an air compressor is driven by a belt the compressor will operate much more evenly and hence with a more uniform pull on the belt if two or more cylinders are used with the crank pins of each placed at an angle with each other.

The “duplex air compressor” is designed on this plan with two cylinders side by side, the crank pins for the two compressors being at an angle of 90 degrees with each other. The motive

power may be either belt, electric motor, or steam engine. If the latter, it is not uncommon to place the steam cylinders tandem with the air cylinders, using a common piston rod, as shown in Fig. 54.

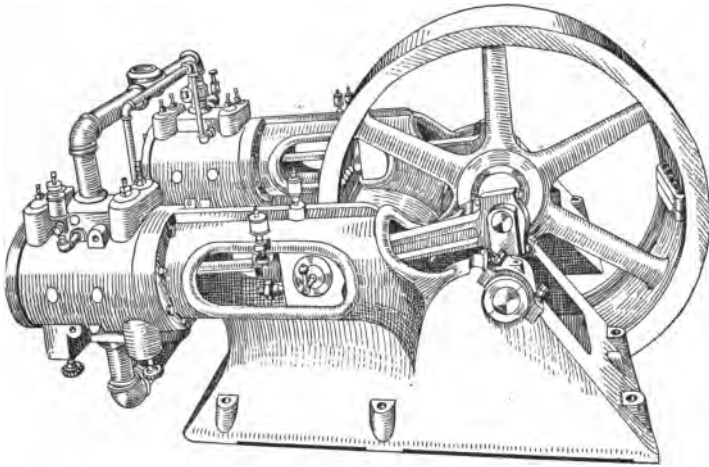

FIG. 53.—Duplex belt-driven compressor.

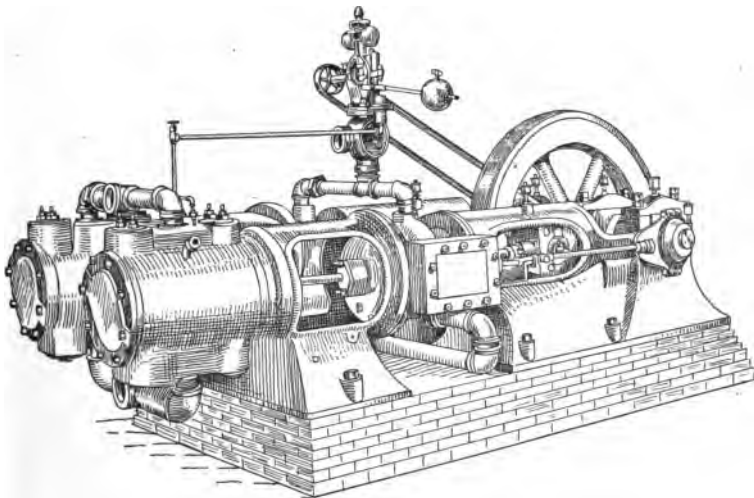

FIG. 54.—Duplex steam-driven compressor.

The steam cylinders may be either cylinders of a cross-compound engine, or two separate simple steam engines. Similarly, the two air cylinders may be cylinders of two separate air compressors or

cylinders of a two-stage compressor. The name "Duplex" is applied to any of these designs.

Figure 55 shows a sketch of the arrangement of cylinders for a two-stage duplex compressor driven by a cross-compound steam engine.

A little study of these sketches will make it clear that with such a duplex arrangement when the greatest power is developed in one steam cylinder, this excess power can be utilized by means of the common crank shaft in overcoming the maximum resistance that is being encountered in the other air cylinder. With the cranks

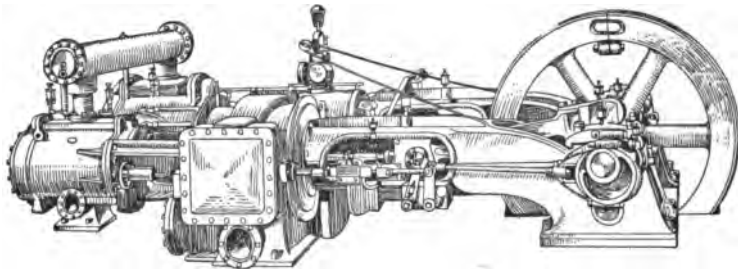

FIG. 55.—Duplex cross compound steam, two-stage air compressor.

90 degrees apart there is little difficulty in starting, even if compound steam cylinders are used, for if the compressor would stop with the high-pressure cylinder at dead center, live steam may be admitted to the low-pressure cylinder by means of a by-pass.

Commercially, the duplex compressor appeals to the trade in that one side or half of the machine may be furnished with fly-wheel and out-board bearing designed for a complete machine, and as the demand for compressed air increases, the output may be increased by installing the remaining side of the machine.

The belt compressor is probably the best type for small capacities when it can be used conveniently, as is the case in a great many factories, for the losses in a steam cylinder, especially of small power, are excessive as compared with the loss of power due to belt transmission.

CHAPTER IX

MULTI-STAGE COMPRESSION

It was pointed out in Chapter VII that it was not advisable to attempt compression above 80 lb. per square inch in a single cylinder because of the loss of energy and danger of explosion due to the resulting high temperatures.

It frequently happens, however, that pressures much higher than this are demanded for commercial purposes, and in order to satisfy this demand, avoid the danger just referred to, and reduce the losses

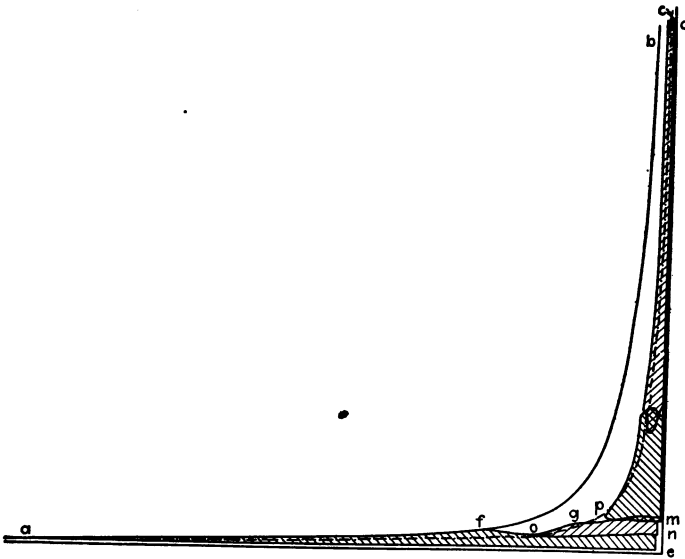

FIG. 56.—Saving due to multi-stage compression.

due to adiabatic compression, engineers have adopted a multi-stage system of compression; compressing the air partly in one cylinder, passing it through an intercooler where its temperature and volume are reduced, then compressing it still further in a second cylinder, and, if the pressures required are high, this compressed air is passed to a second intercooler, thence to a third cylinder and in some cases a

third intercooler and a fourth cylinder are required to secure the desired compression pressure economically.

Advantage of Multi-stage Compression.—The advantages of this system of compression more than offset the extra expense in constructing the compressor. The saving in power required may be illustrated by Fig. 56, where $a-b$ represents the adiabatic line from atmospheric pressure to the required receiver pressure, $a-c$ an isothermal line between the same pressures. The shaded area represents the total work of compression in the four cylinders, the difference between this area and the area $abde$ representing the saving in power due to the multi-stage system of compression. $afne$ represents the work done in the first cylinder, fn the volume occupied by the air as it leaves this cylinder. In the intercooler the temperature of the air, if this part of the apparatus is properly designed, will be reduced to the inlet temperature, and in consequence the volume will be reduced from fn to on . Compression in the second cylinder will raise the pressure to g and reduce the volume of the compressed air to gm . In the second intercooler the volume will be reduced as the temperature is reduced to the inlet temperature from gm to pm , and so on. This secures a compression that requires a smaller expenditure of energy than adiabatic compression, giving results that compare very favorably with the ideal isothermal compression without serious difficulty.

Pressures Used for Various Stages.—Of course this arrangement increases the first cost of the compressor and for that reason the advisability of installing multi-stage compression will depend upon the pressure required. Some authorities recommend two-stage compression for pressures as low as 50 lb., but this practice is unusual. It is certain, however, that for pressures from 80 to 500 lb. the two-stage compressor should be used; for pressures from 500 to 1,000 lb. the three-stage, and for pressure between 1,000 and 3,000 lb. the four-stage compressor.

Intercoolers.—To secure best results care should be taken to see that the intercooler between the different cylinders reduces the temperature of the air as nearly as possible to that of the air at the compressor inlet. As it is important that the flow of air through the intercooler should be as low as possible, it is desirable to reduce the pulsating effect of the discharge of partially compressed air to the intercooler. This is usually accomplished by using large ports and passages.

The larger the volume of the intercooler, the more time for the

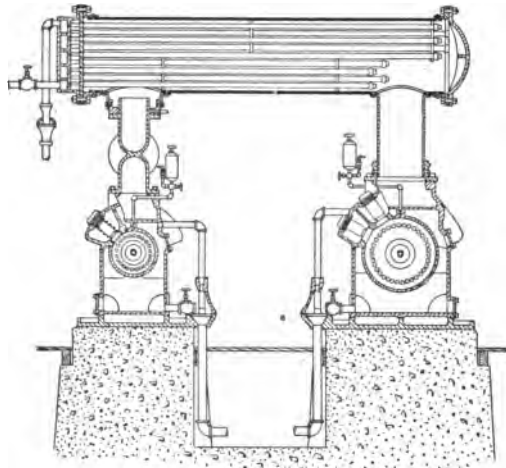

FIG. 57.—Intercooler for duplex two-stage compressor.

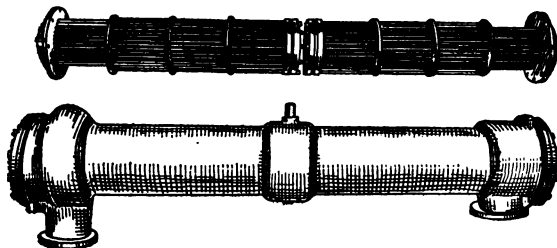
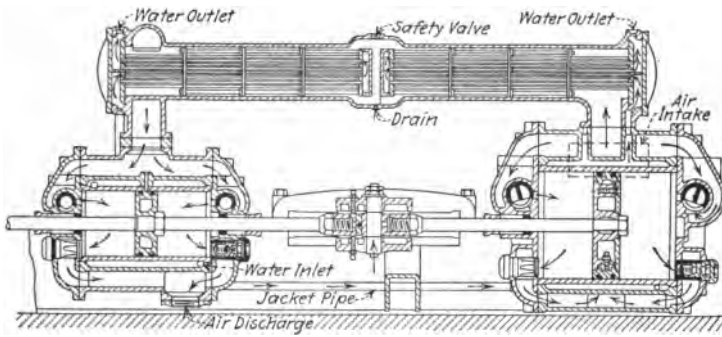

FIG. 58.—Intercooler for tandem two-stage compressor.

compressed air to cool; for this reason "receiver intercoolers," as they are called, are more efficient than those of small volumetric capacity.

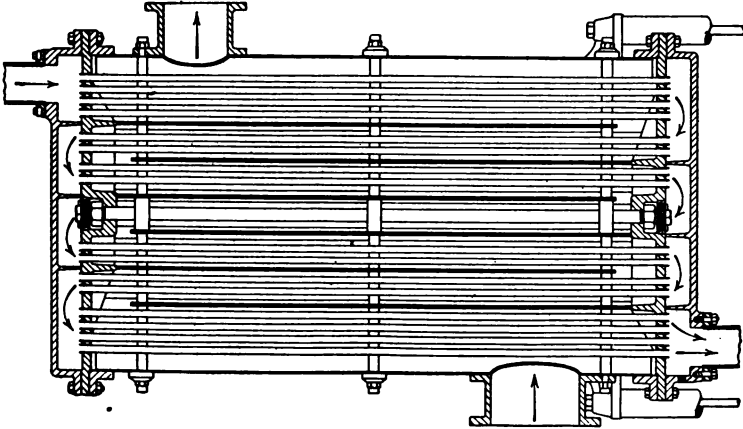

FIG. 59.—Nordberg intercooler.

Types of Intercoolers.—Figs. 57, 58 and 59 show various types of intercoolers. The horizontal type is more frequently used because of its greater adaptability to compressor construction.

In accordance with the fundamental principles of economical transference of heat, it is customary in better types of intercoolers to have the circulation of the water opposite in direction to that of the air being cooled, and also to have the air broken up into as fine streams as possible.

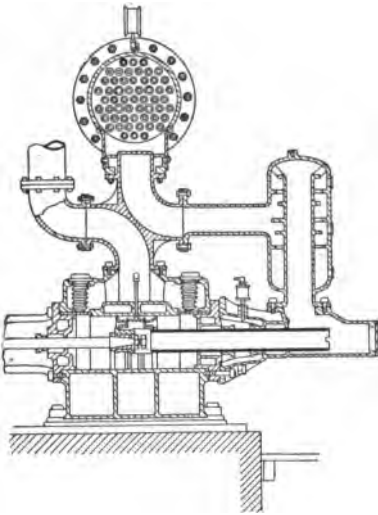

FIG. 60.—Intercooler with separator.

The tubes of intercoolers are usually of iron unless the character of the water used is bad. In this case the tubes may be galvanized or, if the water is salt or contains materials having a corrosive effect on iron, brass or copper tubes are used. In cooling the air, moisture is frequently deposited, and provision

is made to remove this by traps or separators, as shown in Fig. 60.

Perfect intercooling implies that the temperature of the partially compressed air leaving the intercooler shall be as low as the atmosphere. This naturally requires different ratios of cooling surface to cubic feet capacity for different water temperatures.

Cooling Surface and Capacity.—Mr. F. V. D. Longacre gives two charts covering this matter, shown in Figs. 61 and 62. The first shows the intercooler surfacer equired for various water temperatures to secure perfect intercooling for two-stage compression to 100 lb. discharge pressure at sea-level; and the second shows the amount of water required to secure perfect intercooling for this pressure if the cylinder jackets and intercooler are in series, also the amount of water required with a separate jacket, and when the low-pressure and high-pressure jackets are connected in series.

Intercooler Pressure.—In considering multi-stage compression, it is necessary to determine the proper intercooler pressure to secure the most economical results.

It was shown in Chapter IV that the area of an ideal indicator diagram disregarding clearance could be expressed as

$$\frac{n}{n-1} 144 p_a V_a \left[\left(\frac{p_b}{p_a} \right)^{\frac{n-1}{n}} - 1 \right] \text{ ft.-lb.}$$

and if V_a represents the capacity of the machine in free air per minute, the horse-power required, disregarding friction and other losses, will be:

$$\frac{144}{33000} \frac{n}{n-1} p_a V_a \left[\left(\frac{p_b}{p_a} \right)^{\frac{n-1}{n}} - 1 \right]$$

If p_b represents the intercooler pressure, this would represent the horse-power required to operate the low-pressure cylinder, and if the discharge pressure from the high-pressure cylinder be represented by p_d the horse-power required to operate this cylinder would be:

$$\frac{144}{33000} \frac{n}{n-1} p_b V_c \left[\left(\frac{p_d}{p_b} \right)^{\frac{n-1}{n}} - 1 \right]$$

but if perfect intercooling were secured, $p_b V_c$ would equal $p_a V_a$ and the total horse-power required to operate both cylinders of the two-stage compressor would be expressed:

$$\frac{144}{33000} \frac{n}{n-1} p_a V_a \left[\left(\frac{p_d}{p_b} \right)^{\frac{n-1}{n}} + \left(\frac{p_b}{p_a} \right)^{\frac{n-1}{n}} - 2 \right]$$

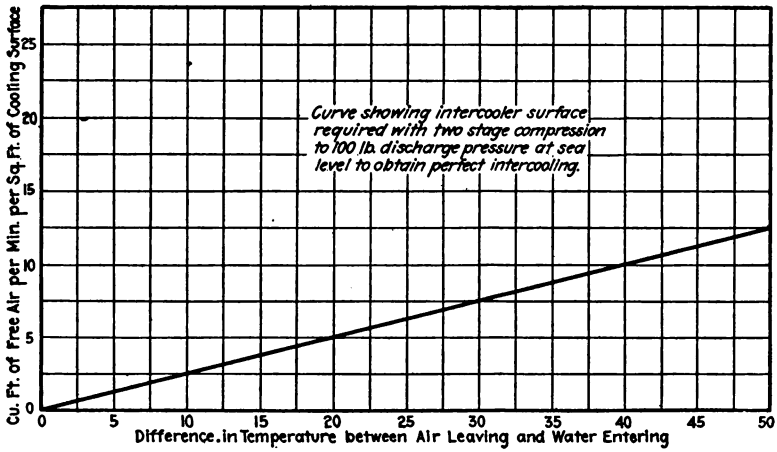

FIG. 61.—Intercooler surface required.

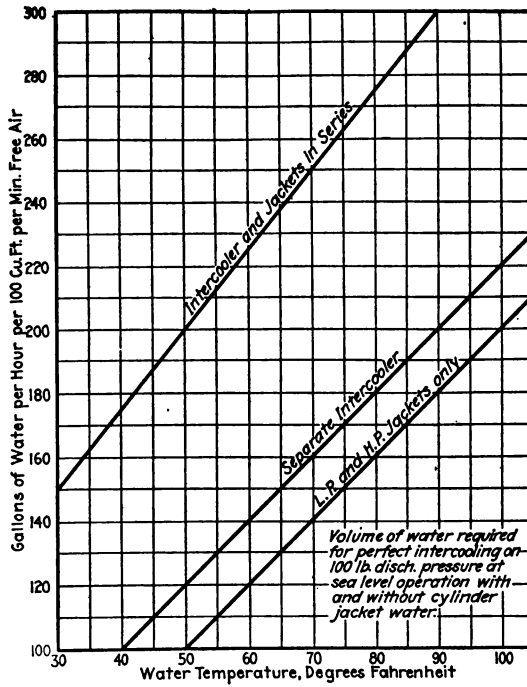

FIG. 62.—Water required for intercooling.

This expression will be a minimum when the part within the brackets is a minimum. As p_a , or the inlet pressure, and p_d , the discharge from the high-pressure cylinder, are fixed, the only variable is the intercooler pressure, or p_b .

Differentiating $\left[\left(\frac{p_d}{p_b} \right)^{\frac{n-1}{n}} + \left(\frac{p_b}{p_a} \right)^{\frac{n-1}{n}} - 2 \right]$ with respect to p_b and equating to zero will give the requisite condition of proper intercooler pressure for minimum expenditure of energy.

$$p_d^{\frac{n-1}{n}} \frac{1-n}{n} p_b^{\frac{1-n}{n}-1} + \frac{1}{p_a^{\frac{n-1}{n}}} \frac{n-1}{n} p_b^{\frac{n-1}{n}-1} = 0$$

$$\frac{1-n}{n} p_d^{\frac{n-1}{n}} p_b^{\frac{1-2n}{n}} = - \frac{1}{p_a^{\frac{n-1}{n}}} \frac{n-1}{n} p_b^{\frac{-1}{n}}$$

$$p_b^{\frac{2-2n}{n}} = \frac{1-n}{n} \frac{n}{1-n} p_a^{\frac{1-n}{n}} p_d^{\frac{1-n}{n}}$$

$$p_b = \sqrt{p_a p_d}$$

That is, for two-stage compression the most economical expenditure of energy is secured when the intercooler pressure is the square root of the product of the given suction and discharge pressure of the machine. As perfect intercooling is assumed, $p_a V_a = p_b V_b$ and the areas of the two cards must be equal, that is, the most economical results are secured when the work of compression is divided equally between the two cylinders.

Let Fig. 63 represent an ideal card of a three-stage air compressor without clearance, in which p_3 represents the pressure in the first intercooler, and p_4 the pressure in the second intercooler. These first two stages may be considered as two-stage compressors between p_1 and p_4 in which, for the most economical results,

$$p_3 = \sqrt{p_1 p_4}$$

and in the same way and for the same reason,

$$p_4 = \sqrt{p_3 p_2}$$

from which

$$p_3 = \sqrt[3]{p_1^2 p_2}$$

and

$$p_4 = \sqrt[3]{p_1 p_2^2}$$

The effect of clearance on the above discussion can be shown by referring to Fig. 64, showing cards for a two-stage compressor

with clearance. The area showing the work done is $AJKLSTZ$, which may be considered as $AJNF + KLEN - ZSEF$. This will evidently be a minimum when the expressions for these areas are a minimum, but as the expression for $ZSEF$ does not contain the

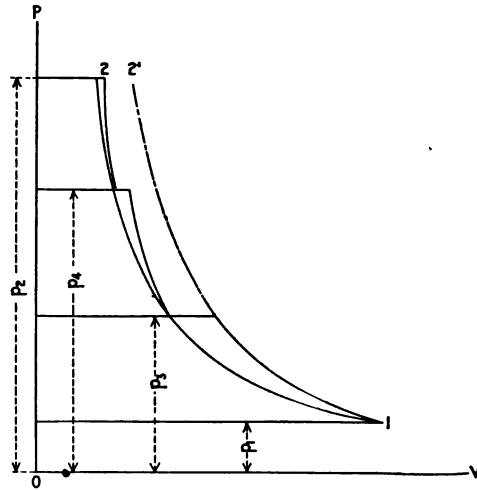

FIG. 63.—Proper receiver pressure for multi-stage compression.

variable p_x , this term will drop out in differentiating and, as a result, it will follow that the intercooler pressure giving the most economical result will be with clearance as without clearance.

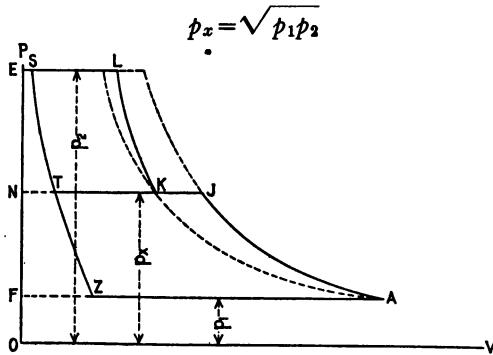

FIG. 64.—Effect of clearance on receiver pressure.

The same method will show that most economical receiver pressures for a three-stage compressor are:

$$p_3 = \sqrt[3]{p_1^2 p_2} \text{ and } p_4 = \sqrt[3]{p_1 p_2^2}$$

when clearance is considered as when clearance is omitted in the discussion.

Effect of Clearance on Volumetric Efficiency.—It was pointed out in Chapter VIII that the real volumetric efficiency of an air compressor could be expressed as

$$\frac{T_{am}}{T_1} \frac{p_1}{p_{am}} \left\{ 1 - C \left[\left(\frac{p_c}{p_d} \right)^{\frac{1}{n}} - 1 \right] \right\}$$

Figure 64 has assumed the clearance in the various cylinders to be proportional, that is, the ratio of clearance volume to piston displacement in each cylinder was such that clearance lines of each cylinder unite to form a continuous expansion line.

If C represent the clearance of the low pressure cylinder and p_b represent the intercooler pressure, p_a the suction pressure and p_e the discharge pressure from the high-pressure cylinder, then the real volumetric efficiency of a two-stage air compressor may be expressed

$$\frac{T_{am}}{T_1} \frac{p_1}{p_{am}} \left\{ 1 - C \left[\left(\frac{p_b}{p_a} \right)^{\frac{1}{n}} - 1 \right] \right\}$$

but as $p_b = \sqrt{p_a p_e}$, this may be written

$$\frac{T_{am}}{T_1} \frac{p_1}{p_{am}} \left\{ 1 - C \left[\left(\frac{p_a^{\frac{1}{2}} p_e^{\frac{1}{2}}}{p_a} \right)^{\frac{1}{n}} - 1 \right] \right\}$$

or

$$\frac{T_{am}}{T_1} \frac{p_1}{p_{am}} \left\{ 1 - C \left[\left(\frac{p_e}{p_a} \right)^{\frac{1}{2n}} - 1 \right] \right\}$$

In the same way, the true volumetric efficiency of a three-stage air compressor may be expressed as

$$\frac{T_{am}}{T_1} \frac{p_1}{p_{am}} \left\{ 1 - C \left[\left(\frac{p_e}{p_a} \right)^{\frac{1}{3n}} - 1 \right] \right\}$$

in which p_e is the discharge pressure from the last cylinder and p_a the suction pressure of the low-pressure cylinder.

Figure 45 shows graphically the effect on volumetric efficiency of compressing by stages and the resulting advantage in capacity.

CHAPTER X

DETAILS OF PISTON AIR COMPRESSORS

Classification of Valves.—Most of the various types of inlet valves for piston air compressors may be divided into two general classes: first, those which are automatically opened by atmospheric pressure and closed by means of their own inertia or weight, by springs, or by air pressure; and second, those which are opened and closed by direct and positive mechanical connection with the crank-shaft or some other moving part of the machine. Each of these classes include many forms of valve design.

Valves of the first class are entirely automatic in their action, their opening and closing points depending entirely upon the conditions of pressure within the cylinder. However, they have certain advantages which will be considered later. Valves of the second class, with one or two exceptions, have their points of opening and closing fixed without regard to changes in operating conditions, and the present tendency among designers and manufacturers seems to be toward valves of this class.

Mechanical Valves.—Nothing can be superior to mechanically operated valves when properly adjusted to operating conditions, as by their aid several of the losses of air compression have been reduced to a minimum.

On the other hand, faulty adjustment of valves, sometimes combined with improper design, renders them extremely low in both efficiency and capacity.

Inlet Valve Setting.—If inlet valves are so set that they open almost exactly when the piston is at the end of its stroke, the card will indicate absolutely no clearance at either end of the cylinder, the clearance air being exhausted into the intake. If the inlet valve closes slightly before the piston reaches the end of its suction stroke, the volumetric efficiency is also reduced.

In case the inlet valves are so constructed that they cannot open until the clearance air has been expanded to atmospheric pressure, the only loss due to this clearance is one of capacity, which may be overcome by an increase in size or speed of piston. If, however,

the inlet valve opens when the piston is in its extreme position, the clearance air is exhausted through the intake, making a direct loss of power as well as of capacity.

Figure 65 is reproduced from a card taken from a machine in which the inlet valves were set to open when the piston was exactly at the end of its stroke. In most of these cases the exhaust through the intake is sufficient to cause considerable noise. Figure 66 shows a card from the same machine with the valves set properly for their particular pressure. This change in the time of opening the inlet

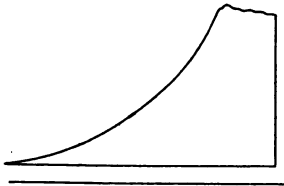

FIG. 65.—Mechanically operated inlet valve opened at end of stroke.

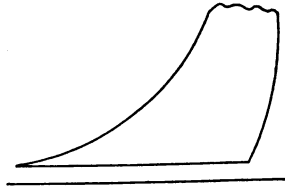

FIG. 66.—Mechanically operated inlet valve properly set.

valve has not effected the volume of air discharged, but the power required to operate the compressor has been considerably reduced and the machine will run more smoothly with less shock to the moving parts at the end of the stroke.

Effect of Changing Discharge Pressure.—If the pressure of discharge is now increased, the former troubles appear again, resulting in a card shown by Fig. 67. If this pressure is to be maintained con-

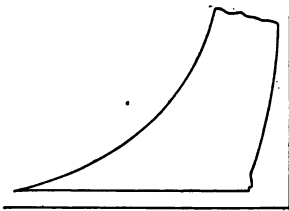

FIG. 67.—Effect of increasing discharge pressure.

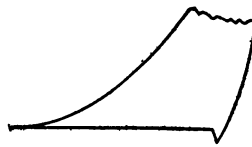

FIG. 68.—Effect of decreasing discharge pressure.

tinuously, the inlet valve will have to be adjusted to open a little later in order to give the best results.

In the same way, if for any reason the discharge pressure should be reduced after the valves have been set correctly, the indicator card will resemble Fig. 68, and if the compressor is to operate con-

tinuously at this lower pressure the inlet valve will have to be adjusted to open a little earlier.

Figures 69 and 70 show indicator cards from improperly set mechanically operated discharge valves with the defect indicated under each.

Every machine with mechanically operated valves should be carefully examined to determine whether they operate at the correct

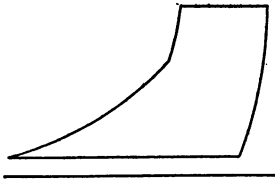

FIG. 69.—Mechanically operated discharge valve opening too early.

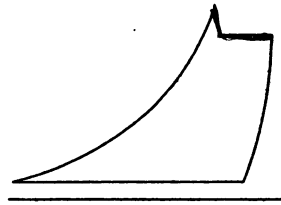

FIG. 70.—Mechanically operated discharge valve opening too late.

time, and if not, should be so adjusted in order to raise the efficiency of operation.

The principal disadvantages of the mechanically operated valves are the increased cost and the extra attention required to keep the valves set properly.

Automatic Valves.—In compressors using automatic valves, however, there is no necessity of timing the valves to suit changes of pressure, as the operation of the valves is controlled entirely by the conditions or pressure within and without the cylinder.

It must be remembered that the majority of air compressors operate at a fixed pressure of discharge and after the valve is once set for this discharge, there is no further need of changing it.

Both types of valves have advantages and disadvantages peculiar to each and a choice of valves should not be made in any important instance without a thorough investigation of all the variable factors involved.

Valve Area.—A very important matter to be considered is the inlet valve area or port opening required for the proper action of a machine. As in other points of design, it is necessary to compromise the desired ends, for the larger the inlet valve the less will be the water-jacketed cylinder surface, and as both are desirable it is impossible to give absolute ratios of inlet areas to cylinder sizes. Some designers make inlet areas 5 per cent. of the piston area, and other

designers use as high as 14 per cent. as the ratio. The design of the valve, the cylinder proportions, and the speed of the machine, all have an influence in determining this point.

The following data is given by the chief draftsman of a large compressor company as the practice of that company resulting from an experience of many years:

"Roughly speaking," 5,000 ft. per minute for the velocity of the air through the valve gives good results. This being the case, a slow-running machine would require a smaller valve than a high-speed compressor with a 'piston-inlet' valve, having a piston speed of from 300 to 350 ft. per minute, the inlet area is from 5 to 6 per cent. of the piston area. On large compressors with a piston speed of from 500 to 600 ft. per minute, the valve area ranges from 6 1/2 to 7 per cent. of the piston area.

The discharge valves which are of the poppet type are from 10 to 12 per cent. of the piston area.

On machines having both inlet and discharge valves of the poppet type, the ratio should be about 12 per cent. for machines of that speed. For piston speeds not exceeding 400 ft. per minute it is probable that 10 per cent. is enough.

The area of the discharge valve should not be less than that of the inlet, for although the volume of discharge is less than the volume of admission, this discharge must take place in a considerably shorter space of time.

Forms of Poppet Valves.—Probably the automatic poppet valve is the most common form of valve in use. A few designs are shown in Figs. 71 and 72.



FIG. 71.—Air inlet valve.

The principal difficulty to guard against in the design of an automatic valve is to avoid the possibility of the valve itself being drawn into the cylinder with the in-rushing air. This may happen through the breaking of the spring and disastrous results frequently happen, for on the return stroke of the piston, the cylinder head, or the piston, or some other part of the apparatus is sure to suffer.

Figure 73 illustrates a peculiar valve designed for a single-acting compressor, *i.e.*, a type of piston compressor in which the air com-

pression takes place on only one side of the piston instead of both as is usually the case. *B* is the inlet valve which is located in the center

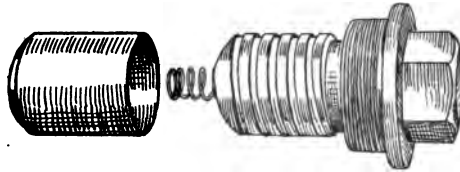

FIG. 72.—Air discharge valve.

of the piston and is held on its seat by the spring *D*. The discharge valve *A* is a radical departure from the older designs of compressor

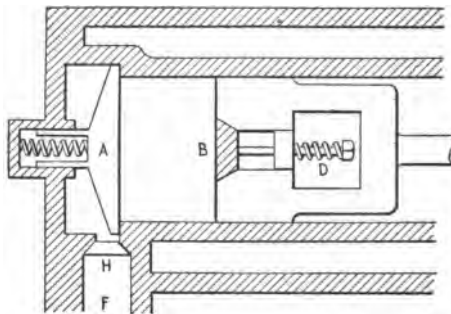

FIG. 73.—Valve in cylinder head.

valves, being a flat disc covering the entire area of the cylinder and held in its seat by a guide and spring.

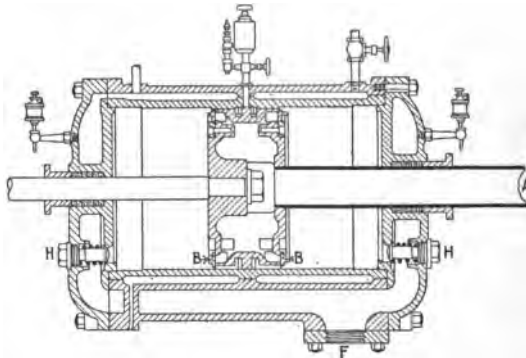

FIG. 74.—Piston inlet valve.

Its face and the face of the piston are perfectly flat, so that the piston may strike the valve and deliver all the air with no clearance

space to reduce its capacity. A large area of discharge is obtained by a very small movement of the valve and no pounding is made by its action, for the compressor is of the straight-line type and the compression in the steam cylinder acts as a cushion to relieve the pounding that might otherwise occur with no clearance.

Piston-inlet Valves.—One of the most interesting forms of inlet valve is the piston-inlet valve, as manufactured by the Ingersoll-Rand Company, a sketch of which is shown in Fig. 74. By this arrangement the entering air comes in through the tube *A*, which projects through the head end of the cylinder. The air passes through this to the center of the piston which is hollow. Communication is obtained from this hollow piston to the cylinder through the ring-shaped valves *B*, which are made of open-hearth steel in one piece without a weld. These valves have a movement of about $\frac{1}{4}$ in., and are held in place by pins which are set in slots in the valve.

The two inlet valves *B* and the tube *A* are carried back and forth with the piston. The valve on that face of the piston which is toward the right is closed as the piston moves to the right, while that on the left side is open to admit a fresh supply of air to the left side of the piston while air is being compressed on the right side.

When the piston reaches the end of its stroke, the inlet valve closes because of its own inertia and as the piston starts on the return stroke the valve that was formerly closed is now left behind for about $\frac{1}{4}$ in. of the piston travel and remains open during the entire stroke. When the valves are closed, their face is almost flush with the piston face, thus reducing the clearance space to minimum.

There are no springs in the construction of this valve, and it has been found to work equally well with slow or high speed. These valves are guaranteed by the company for five years.

Discharge valves are shown at *H*. These conduct the compressed air to the discharge pipe *F*.

All these types of automatically operated valves have the advantage that they adjust themselves to meet varying changes in air pressure automatically.

Semi-mechanical Valves.—There are several types of semi-mechanically operated valves on the market. Some of these consist essentially of an arrangement of levers to remove the action of the spring on the inlet valves during admission, permitting the valve to open instantly and freely and remain open without any clattering

until the end of the stroke, when the spring tension is permitted to act on the valve and close it.

Attention has already been called to the fact that many automatic valves close before the end of the stroke, due to the fact that the piston is rapidly reducing its speed at that time. If the inlet valve

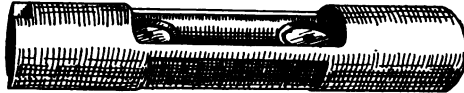

FIG. 75.—Mechanical valve of Corliss type.

closes before the end of the stroke, the volumetric efficiency is naturally reduced, and on this account the mechanically operated inlet valve is preferred by many engineers.

In addition to the mechanical operation of poppet spring valves just mentioned, some air compressors are equipped with valves

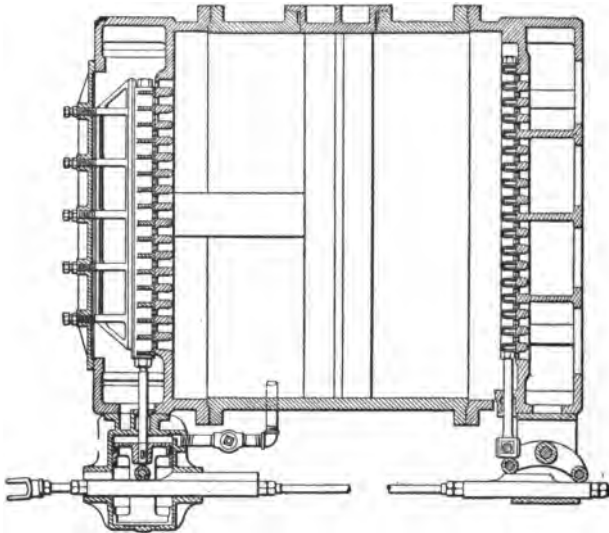

FIG. 76.—Southwork blowing engine valve.

which resemble in action and appearance Corliss steam valves. Fig. 75 gives an illustration of this form of valve, which is opened and closed by a rotating motion, given to them by levers from a wrist plate or eccentric.

This type of valve is sometimes used for the discharge valve on compressors, but cannot be operated successfully for very high

pressures because the clearance is made excessive. Mechanically operated valves are usually used on large blowing engines for blast furnaces. One type is shown in Figs. 76 and 77. In this type of compressor, it is desirable to secure large, free opening for suction, and one of the latest designs consists of a large cylinder on the outside of the compressing cylinder which reciprocates back and forth, and in so doing opens large slots at the end of the cylinder, giving very free opening for inlet.

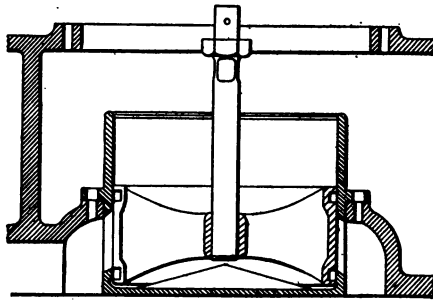

FIG. 77.—Kennedy blowing engine valve.

Regulators, Unloading Devices, Etc.

It is often essential that the pressure of air in an air receiver be kept constantly at a fixed point and as the number of tools using air at the same time will vary in any installation, some automatic device must be used so that the compressor will be furnishing air when needed and when no air is needed this device must prevent any unnecessary work being done at the compressor. There will be times when every tool that is taking air from the receiver will be in operation and the compressor must have a capacity sufficient for such occasions; and again there will be times when none of the tools are in operation and the work at the time being done at the compressor would be in excess of the needs if some automatic system of regulation is not used.

Belt Regulator.—Probably the simplest form of regulator is the one that is often used on belt-driven air compressors. This consists of a belt-shifting device so arranged that when the pressure gets above the desired point the belt is shifted off the compressor wheel and onto a loose pulley. When the pressure falls below this fixed point the belt is shifted back again, and the compressor is thus

automatically started and stopped to suit the changing amount of compressed air that is needed.

Westinghouse Governor.—Fig. 78 shows a sketch of the governor used on the Westinghouse air brake. It consists of a piston *A* moving in a cylinder and directly connected to the steam valve *C* which supplies steam to the air compressor, or air pump as it is more commonly called. A spring, *D*, helps to hold this up and hence keep the steam valve open. Pipe *E* leads from the air reser-

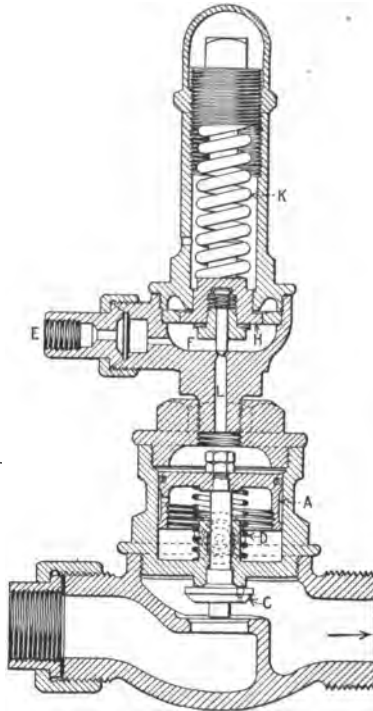

FIG. 78.—Westinghouse governor.

voir to the governor. Communication between *E* and the cylinder above *A* is closed by a needle valve *F*, which is held on its seat by the governor spring *K*. When the air pressure in the main reservoir gets up to its maximum, the pressure in *E* is sufficient to raise the small piston *H* against the governor spring *K*, lift *F* from its seat and allow the air to press on *A* and thus close the steam valve and stop the air pump. A small opening, *L*, allows the air above *A* to escape gradually into the atmosphere. As air is used in releasing

the brakes, the pressure in the reservoir will be reduced, and when this happens, spring *K* can overcome the air pressure and seat *F* and spring *D* will then raise piston *A*, open the steam valve *C* and start the pump.

The governor used for controlling the compressor for electric-driven air-brake systems consists of an ordinary Bourbon pressure gage with a special needle or hand, which upon coming in contact with a stud at the position of minimum pressure causes an electric current to flow through a magnet coil. This coil operates a plunger to which the contact pieces for the motor circuit are attached and

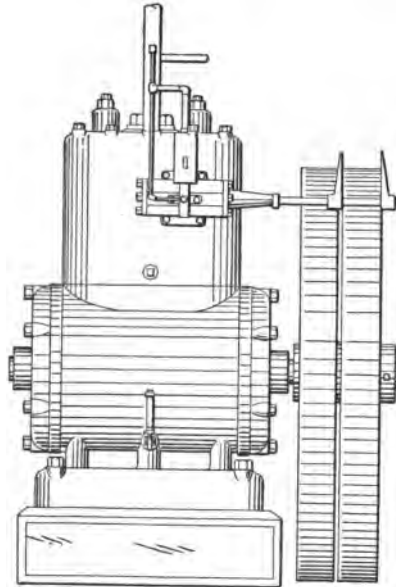

FIG. 79.—Belt regulator.

in this way the circuit is closed and the motor started. As soon as the air pressure reaches the desired maximum the gage hand strikes another stud, causing current to pass through a second solenoid magnet which pulls the plunger referred to in the opposite direction and stops the compressor motor.

By this mechanism it is possible to get a close margin between the maximum and minimum pressure. This margin can be changed by moving the studs.

Figure 79 shows a form of regulator for belt-driven compressors which stops the compressor when the desired maximum pressure

is reached. When the desired upper limit is reached the belt is shifted from the tight to the loose pulley.

Norwalk Regulator.—One of the simplest forms of regulators for steam-driven air compressors is the one made by the Norwalk Iron Works shown in Fig. 80. It consists of a balanced steam valve *A* placed in the steam-pipe near the steam cylinder and controlled by the air pressure in the receiver. A small cylinder *B*

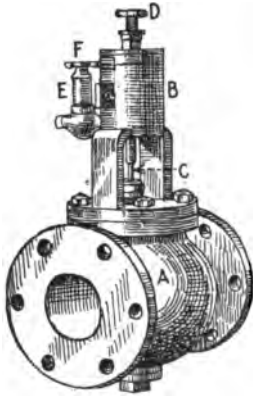

FIG. 80.—Norwalk governor.

contains a piston connected with the balanced valve *A* by the stem *C*. Above this small piston is a stop screw *D* projecting above the cylinder head for regulating the lift of the piston. The air from the receiver is led through a small safety valve *E* which regulates the pressure at which air can escape into the cylinder *B* to move the piston. Above the disc of the small safety valve is a spring whose tension is regulated by a screw *F* allowing the pressure at which air is permitted to enter cylinder *B* to be changed at will. The air passes into cylinder *B* below the piston and if no escape were provided would drive the piston to the top of *B*. To regulate this a very fine

slot is cut in the side of the small cylinder. When the piston rises it uncovers this slot and thus furnishes an escape for the air which is passing the safety valve. If only a little air enters then a small part of the slot will accommodate it and the piston will take a low position. With more air escaping the piston will rise higher and uncover more of the slot, thus providing a larger opening for its exit. As the slot is very fine, a very little difference in the quantity of air will cause the piston to assume a high or low position. After the small safety valve begins to blow an almost insensible increase of pressure in the reservoir will furnish enough more air to carry the piston to the top of the cylinder. Thus any degree of regulation is obtained by a very little difference of pressure, as the air which works on the piston in the small cylinder has only to perform the work of lifting the piston and valve sufficiently to uncover enough of the slot so that it can escape; its pressure is very slight.

The piston is fitted loosely and the whole apparatus moves as nearly without friction as can be imagined.

When this regulator is applied to compressors having a single steam cylinder, it is possible for the valve to be carried so high as to cut off all steam and to stop the engine on the center. This would be objectionable. To obviate this, there is placed on the top of the small cylinder a screw stop which can be set to prevent the closing of the steam valve more than is sufficient to run the engine at the slowest possible speed.

Combined Governor and Regulator.—Another combined speed and air-pressure governor is shown in Fig. 81. This not only

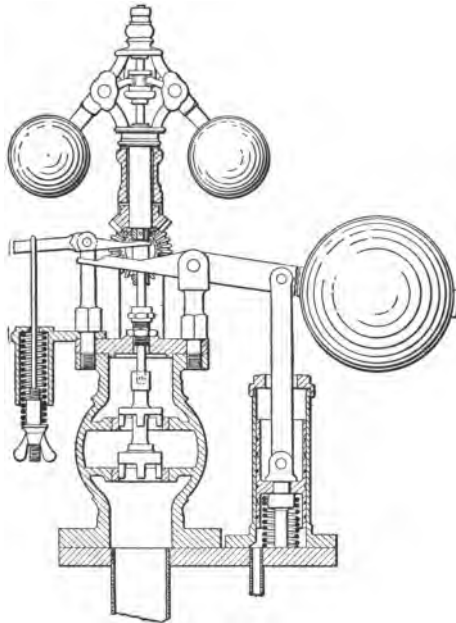

FIG. 81.—Clayton governor.

performs the functions of an air governor, but also prevents the compressor from operating at an injurious speed should a sudden drop in the air pressure produce a greater demand upon the compressor than its highest reasonable speed can supply. It consists simply of an adjustable stop attached to an ordinary centrifugal ball governor. This stop is adjusted to suit varying pressures of air in the receiver caused by the varying demands that are made on it.

Nordberg Governor.—A combined air and speed governor manufactured by the Nordberg Manufacturing Company of Milwaukee, Wisconsin, is shown by Fig. 82. In this type of governor the speed

of the engine is controlled not only by the centrifugal action of the governor but also by any variation of the air pressure. The arm *A* controls the point of "cut-off" for the steam cylinder and is operated by the movement of the bell-crank *C* about the fixed point *D*. The rod *E* controls the bell-crank and is connected to what is called a

floating lever *B*. This lever *B* is connected with the centrifugal governor *F* at *J*, and with a piston which is in communication with the air pressure at *G* and is held up by a weight *H*.

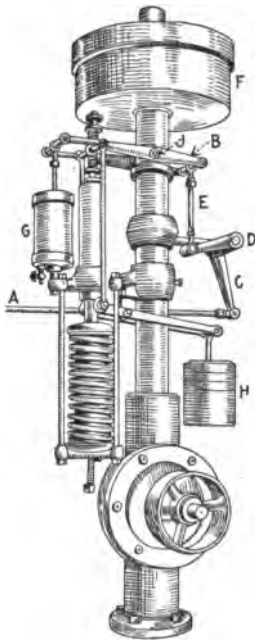

FIG. 82.—Nordberg governor.

It is evident from this arrangement that if the point *G* should remain stationary and the point *J* should lower, rod *E* will be forced downward and *A* to the right; also, if point *J* should remain stationary and point *G* should rise, the same movement will occur, and *vice versa*.

That is, if the air pressure should rise above normal, the engine will have its supply of steam per stroke reduced, and if the air pressure should fall, the supply of steam will be increased; or, if the pressure of air remains constant, the governor will have the same control over the speed of the engine that the ordinary centrifugal governor has.

Unloading Devices.—Sometimes an air compressor must be kept running at constant speed, and in order to prevent it from doing unnecessary work when the consumption is not equal to the capacity of the compressor, a device is used to remove the work or load of the air piston and allow it to move back and forth in its cylinder without doing any work. These are called unloading devices. Fig. 83 shows the principle upon which many of them operate. 61 represents a valve on the inlet pipe which is closed when the load is to be removed, preventing air from entering the cylinder. These unloading devices are frequently made use of in starting air compressors without any load until full speed is reached, when the load is put on as desired.

Clearance Unloader.—One of the most recent unloading devices is arranged to vary the clearance on the compressor as the load changes.

This device is illustrated in Fig. 84 and its effect or operation is shown by the indicator cards of Fig. 85.

This automatic clearance controller, as it is called, consists of a number of clearance pockets which are thrown automatically into communication with the ends of each air cylinder in proper succession, this process being controlled by a predetermined variation in receiver pressure.

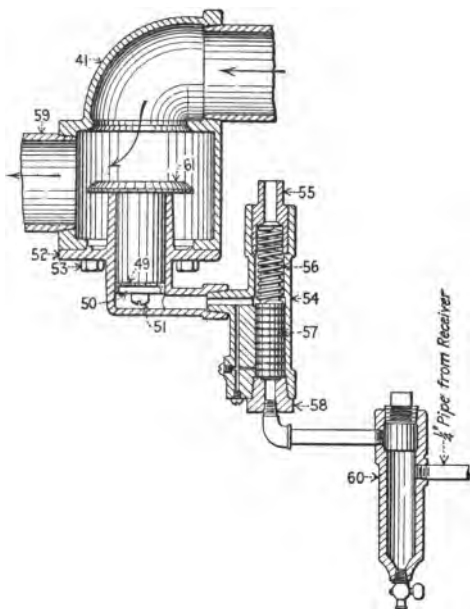

FIG. 83.—Rand imperial unloader. 41, unloader body; 49, unloader cup leather; 50, unloader follower; 51, unloader follower screw; 52, unloader cylinder; 53, unloader cylinder cap screw; 54, unloader regulator cylinder body; 55, unloader adjusting plug; 56, unloader valve spring; 57, unloader piston; 58, unloader inlet plug; 59, unloader nipple; 60, unloader dirt collector; 61, unloader plunger.

Regulation is obtained in five stages, viz., full-load; three-quarter-load; half-load; quarter-load, and no-load.

When the compressor is operating at partial capacity, the clearance space of the compressor is increased and, as a result, its volumetric efficiency is reduced without changing the suction or discharge pressures, or the speed of the compressor.

On two-stage compressors these controllers are placed on both cylinders, thus maintaining a constant ratio of compression. The device is automatic and very satisfactory for use on compressors which are motor driven, or must, because of their method of operation, be driven at constant speed.

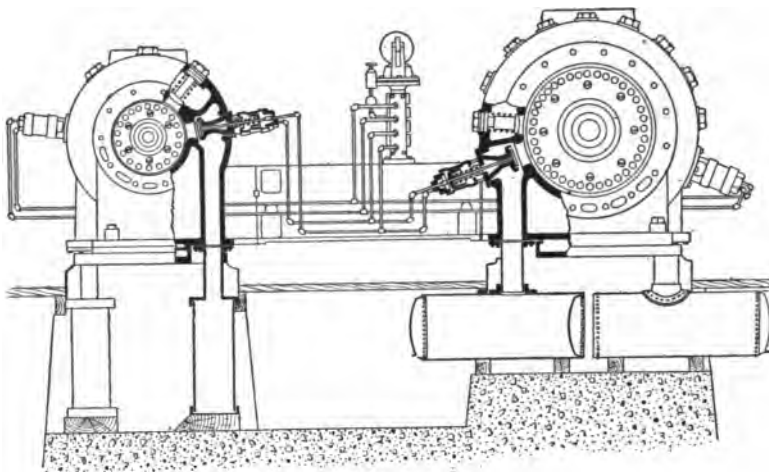

FIG. 84.—Clearance unloader.

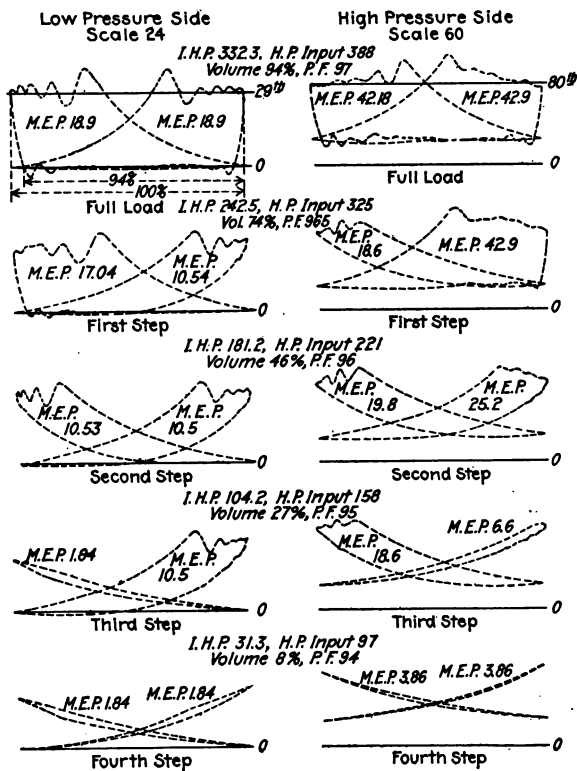

FIG. 85.—Cards showing clearance unloader.

CHAPTER XI

TURBO-COMPRESSORS

The *Engineering Magazine* in recent issues has given a series of five articles on turbo-blowers and compressors by Franz zur Nedden, Superintending Engineer of Weise and Monski, Halle-Saale, Germany, from which the following material and illustrations have been gathered.

The introduction of the steam turbine as a competitor of the reciprocating engine has necessitated a similar change in the design and construction of pumps, blowers, and compressors and has naturally led to the production of turbine machines built for compressing air or gases.

The advantages of turbo-compressors, however, are not so apparent in small as in large size units, and the high cost of such units in the experimental development of this machine has made its introduction rather slow.

The recent development, however, of exhaust steam turbines has stimulated the use of turbo-blowers.

"It is well known that the economy of the steam turbine increases directly with its rotative speed, and even electric generators of the highest speeds are slow-running machines when compared with the steam turbine operating at the number of revolutions required to secure the best economy. The turbo-compressor, like the steam turbine, becomes more and more economical the faster it runs, and is therefore a proper companion of the steam turbine. Speeds of 4,000 revolutions per minute and even more are not unusual to the design of turbo-compressors.

"If large volumes of compressed air are wanted in plants where considerable quantities of exhaust steam are available at the same time, the coupling of an exhaust-steam turbine with a centrifugal compressor becomes an ideal arrangement, and the combination is far superior in economy to the piston compressor driven by an electric motor or a high-pressure steam engine."

Design of Turbo-compressors

"In studying the development of turbo-compressors it is most interesting to observe that Rateau and Parsons dealt with the problems of design quite differently.

“Rateau Blower.—Prof. Rateau did not take the structural features of his new machine from his steam turbine, but from his high-lift turbine pump. His turbo-compressor and turbo-pump are so similar that a superficial inspection of the drawing of the two machines might not reveal the difference (Fig 86).

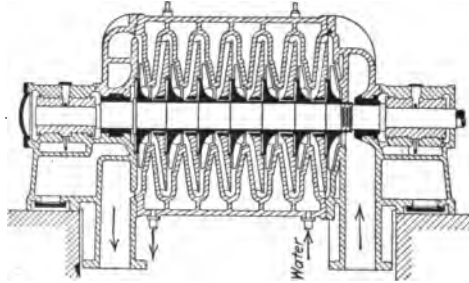

FIG. 86.—Original Rateau turbine blower.

“The air upon entering the impeller near its nave is seized by the impeller blades and thrown outward radially. Its kinetic energy due to velocity upon leaving the periphery is changed into pressure in the fixed diffuser channel, and being led back toward the center the air enters the second impeller to undergo the same process in a second stage and so on. Some essential differences in the design of details will be taken up later on.

“The Parsons Blower.—Mr. Parsons, on the other hand, made the turbo-blower merely an inversion of his steam turbine. Fig. 87 shows a unit consisting of a standard Parsons steam turbine (on

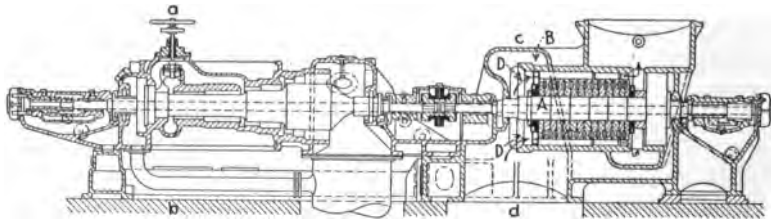

FIG. 87.—Parsons turbine blower with steam turbine.

the left-hand side) coupled direct with a turbo-blower of the usual Parsons type, and delivering 1,600 cu. ft. per minute against a pressure of 6 to 20 in. of mercury at speeds varying from 2,400 to 3,400 revolutions.

“The air is drawn into the chamber *B*, and conducted into the periphery blades of the runner *A* by fixed guide blades *D*. The following blades are not shown in the section merely for simplicity of outline.

“The principal divergence from the Rateau design is that the impellers of the Parsons turbo-blower throw the air in an axial direction to the next guide apparatus. Parsons undertook to transform the kinetic energy of the air as it leaves the impeller blades into pressure by simply opposing plain straight blades against its flow. The second guide-wheel transmits the air axially to the second impeller, which again throws it axially into the third guide-wheel, and so on. Fig. 88 shows a developed section through several rows of blades.

“The excellent reputation of the Parsons machines helped the introduction of his turbo-blower, which was rapidly accepted and

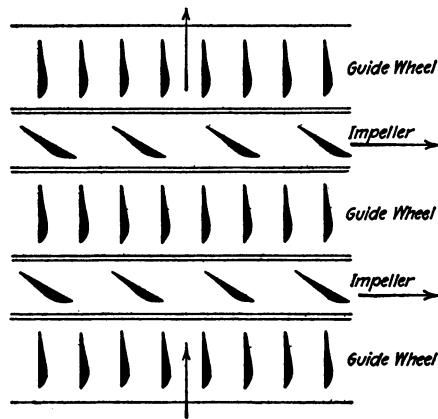

FIG. 88.—Developed section of Parson's blades.

put into practical operation. At a time when more than a dozen Parsons blowers were in operation or under construction, Rateau was still experimenting with his first turbo-blower. Nevertheless, Prof. Rateau succeeded in making up this delay and soon advanced to the point of combining several of his blowers in series, thus proceeding to obtain final pressures of 100 to 150 lb. per square inch. The excellent results which he and his assistant, Prof. Armengaud, obtained from their high-pressure machines induced even the licensees of Parsons steam-turbine patents to secure rights for the Rateau turbo-compressors. A careful comparison of both systems will disclose some reasons for the rapid adoption of the Rateau system.

“**Cooling Turbo-compressors.**—Increase of temperature makes special cooling arrangements indispensable, especially with turbo-compressors, *i.e.*, with machines compressing air to more than 20 lb. per square inch absolute pressure. Economical cooling becomes

a vital question in the thermal efficiency of the compressor. On this point it decidedly excels the piston compressor, as it is impossible to cool the air continuously when it is compressed in cylinders. (See Figs. 89 and 90.) Here jacket cooling is the most important part of the whole cooling system, and the special intermediate coolers used between the separate cylinders of compound piston

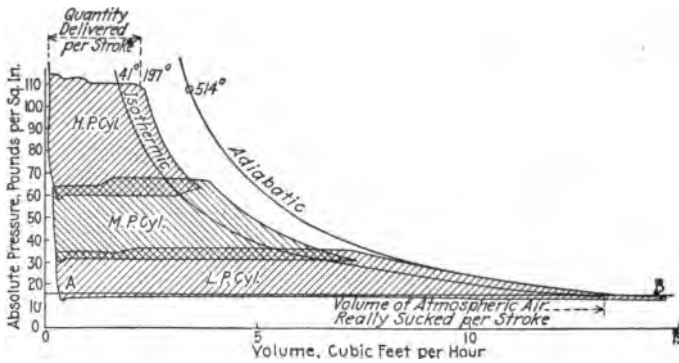

FIG. 89.—Diagram three-stage piston compression.

compressors are generally considered wholly unnecessary in the turbo-compressor. In the turbo-machine compression of the air proceeds much more gradually, the distance traveled by every particle of air is consequently much greater than with piston compressors, and the entire area available for the cooling influence of the water is

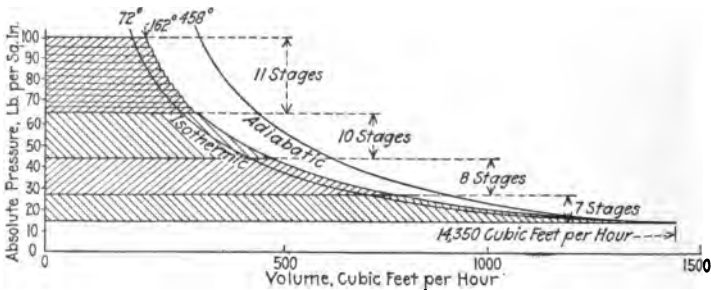

FIG. 90.—Diagram of tubo compression.

many times as large as that in the piston compressor of equal capacity; therefore, the air pumped by the turbo-compressor can be kept at nearly constant temperature throughout the operation. Cooling arrangements of the counter-current type can easily be used to give maximum effectiveness, a condition not readily attained in compressors of piston type.

COOLING DEVICES

“The principal differences noticeable between various turbo-compressor systems are in their cooling arrangements. The various licensees of Prof. Rateau do not use a uniform cooling device. Fig. 91 shows one of the first water-cooled Rateau compressors which has been successful in practical operation. Fig. 92 shows its internal features. Each of the three groups coupled in series contains seven

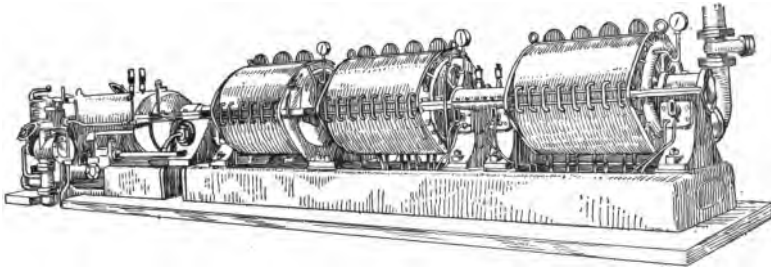

FIG. 91.—Water-cooled turbo compressor.

or eight stages. Each casing is separable horizontally into two parts, a form which seems to have become standard for turbo-compressors as it has for steam turbines. The cooling water enters the casing from below at the highest pressure stage of the group. It passes thence to the upper part through copper tubes, shown in Fig. 91, goes through a core-hole at the top of the highest stage into the upper half of the highest stage but one, and again through copper

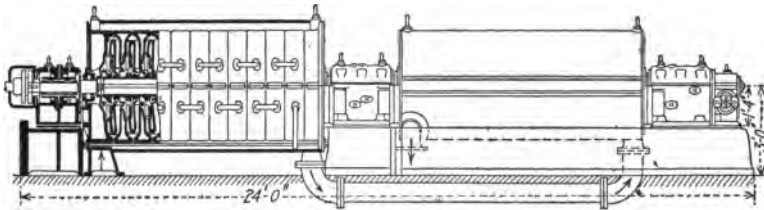

FIG. 92.—Turbo compressor built by Brown, Boveri and Co.

tubes into the lower half, whence it goes through a core-hole into the lower half of the next lower stage, and so on. Later, the copper pipes were replaced by small bored holes passing through the horizontal joints. (See Fig. 92.) This system has the disadvantage that there is no assurance that the water shall completely fill up the cooling chamber, as the core-holes are not always at the very highest points of the chambers.

“Messrs. Brown, Boveri & Co. avoided this difficulty, and, more-

over, greatly enlarged the cooling area by casting the vanes hollow, thus leading the air back to the center and creating a separate interior cooling chamber *B*, Fig. 93. The water, after filling chamber *A*, flows through the hollow guide vane into chamber *B*, and thence by

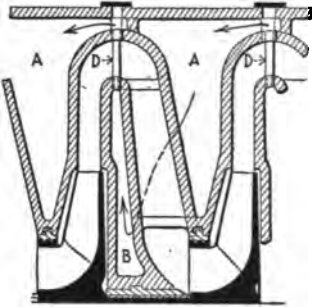

FIG. 93.—Improved cooling system for turbo compression.

special pipe *D* (which is screwed into chamber *B* at its highest point) to the highest point of chamber *A* of the next stage. Though the excellence of this system cannot be denied, it is, on the other hand, very expensive, for the castings become highly complicated, and the foundry work, moreover, must be such as to guarantee that all surfaces are absolutely smooth, as the frictional resistance of air is dependent on the roughness of the surface over which it passes. The cost of casting these casings was about 5 1/4 cents a

pound in place of 3 1/2 for average casings, and even then this famous foundry could not avoid 15 to 20 per cent. waste.

“C. H. Jaeger of Leipzig wisely separates the casing of his turbo-compressors into as many chambers as there are stages, and screws these together as shown in Fig. 94. Furthermore, he separates each

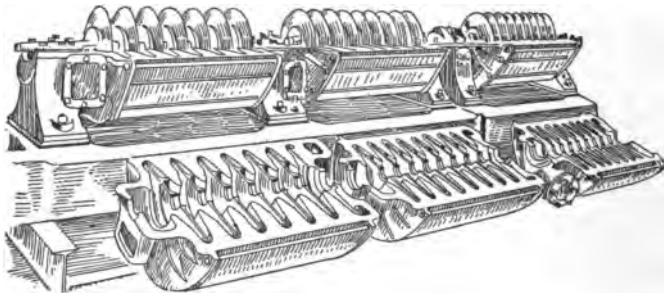

FIG. 94.—Water-cooled Jaeger turbo compressor.

stage into an upper and lower half. Though this system increases considerably the number of machined surfaces, it nevertheless insures small casings and enables the maker to manufacture the single stages on a large scale and to combine out of stock as many as are needed for any special requirement.

“**Expansion of Casing.**—Another effect of temperature rise, and one which acts on the machine, is the expansion of the casing by heat. Special preventive measures must therefore be taken to avoid

any alteration in the relative position of the casing and the runners. As the casing rests by lateral supports on the bed-plate, the absolute height of its center above that bed-plate will change as soon as the casing becomes heated and expands. If the shaft, revolving within this casing with a clearance as small as $1/1000$ of an inch, is supported by bearings which remain practically cool, the distance between the center of the shaft and the bed-plate will remain unchanged. Therefore, the centers of the casing and of the shaft, which may coincide when both are cold, must differ as soon as the blower comes into operation and the temperature of the casing rises. The clearances will then not only become eccentric, but very probably the shaft and the vanes of the impellers will come into close contact with the fixed parts, causing heavy friction, and because of the absence of any lubricating medium they would very likely seize.

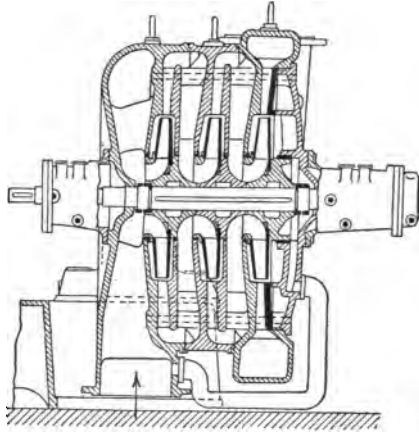

FIG. 95.—Jaeger's turbo-blower.

“Designers of turbo-compressors have overcome the difficulty of axial expansion by means already well known in the steam engine and the piston compressor. These difficulties are, of course, larger with long-extended turbo-compressors than with single-casing turbo-blowers. The blower illustrated in Fig. 95 rests with one end only on the bed-plate, the other end being free to move or expand. When additional stages are required, the design must be altered to a form now quite generally adopted by the licensees both of Prof. Rateau and Messrs. C. H. Jaeger & Co. The body is supported only by the two terminal covers which carry the bearings. One of the bearings is fixed rigidly to the bed-plate, while the other is allowed to slide to some extent on the machine rest. (See Fig. 94.) With very long blowers, it might perhaps be advisable to support the body by lateral feet, the machined surfaces of which might move freely on the bed-plate on exactly the same horizontal plane as the axis of the blower. In this way radial expansion would not alter the height of the geometric center of the casing above the bed-plate.

“**Runners.**—Many of the problems that had been solved in designing steam turbines assisted in the solution of the design of turbo-blowers, but although Parsons was able to adapt his steam-turbine

runners to his blower, the original designs of Rateau and Jaeger had unsymmetrical runners, which had a tendency to become deformed under high speed. This difficulty was finally overcome by the use of impellers made with a solid hub with blades and lateral flanks of pressed sheet-nickel steel, as shown in Fig. 96.

"It is not very difficult to insure tightness between the single stages of turbo-blowers and turbo-compressors. The pressure

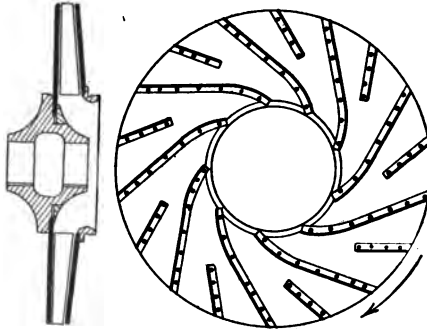

FIG. 96.—Jaeger's patent impeller.

differences against which the clearances have to be kept tight are comparatively small, as the delivery pressure is distributed over many stages; and, on the other hand, long clearances are secured almost automatically as the stages are placed one after another in the casing. With air, as with water, the leakage resistance of a clearance is greater the longer and narrower it is, but the problem

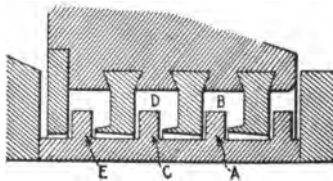

FIG. 97.—Labyrinth bushing.

of maintaining tightness against leakage with gaseous media is facilitated by the labyrinth effect which is utilized on a large scale in the manufacture of steam turbines.

"Figure 97 shows such a labyrinth as used by Brown, Boveri & Co., the action being briefly described thus:

"The air passing through the small clearance *A* expands as it enters the following chamber *B*. By this expansion its pressure is greatly decreased, and it traverses the second clearance *C* at a con-

siderably lower pressure than that at which it passed through *A*; owing to the expansion in the second chamber *D*, still less pressure is left for forcing the air through the third clearance *E*, and so on, and it is therefore impossible for any considerable quantity of air to pass the labyrinth.

“Balancing Axial Thrust.—The only point at which any great loss of air occurs is in connection with the usual methods for balancing the axial thrust. Special arrangements for this balancing become necessary, for, as with centrifugal pumps, the annular area opposite the entrance to each impeller is subject to a heavier pressure than the entrance itself. And, as with centrifugal pumps, there are several ways of obtaining perfect balance, perhaps the best being that illustrated in Fig. 98.

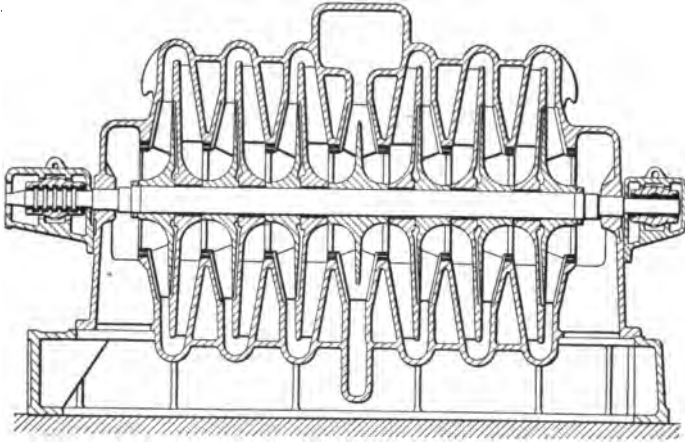

FIG. 98.—Turbo blower of 25,000 cu. ft. capacity.

“Balance by Counter-position.—Here the blower draws the air from both sides, and delivers it after both halves of the entire quantity have been compressed separately in wheels of the same dimensions through which they pass in opposite directions. Thus, any axial thrust arising in a wheel on one side is balanced by an equal thrust exerted by a corresponding wheel on the other side. This advantage of balancing axial thrust most perfectly, and practically without any leakage losses, is paid for, however, in this instance by a cumbersome arrangement and poor efficiency. It is obvious that the use of double the number of rotating sheaves for compressing the same quantity of air doubles also the amount of energy lost by frictional resistance. In other words, a blower like that shown in Fig. 98 is simply two blowers, each for half the delivery, coupled in parallel; and, as the efficiency of all rotating machines drops with

decreasing delivery, it is clear that the efficiency of these two blowers must be lower than if the whole quantity were dealt with in one single machine.

“Balancing by Diminishing Back Area.—Another design which is standard in the blowers of some of Prof. Rateau’s licensees, for

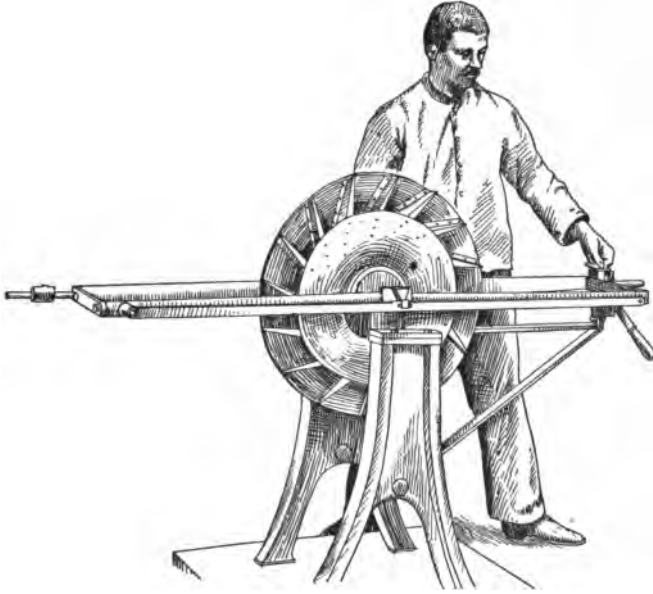

FIG. 99.—Balancing Rateau impellers.

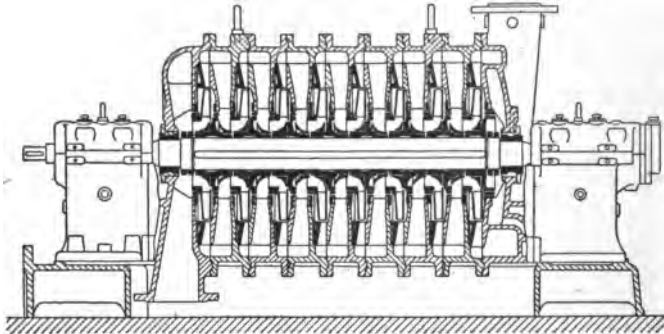

FIG. 100.—Piston-balanced turbo compressor.

example the Skoda-Werke at Pilsen, and Messrs. Kuehnle, Kopp & Kausch, at Frankenthal, is adopted from the well-known Rateau turbine pumps. The excess pressure acting on the back of each

impeller can be cancelled by simply diminishing this back area *pro rata* with the increase in pressure. This is done by leaving free an annular margin at the periphery of the back of each impeller as shown by Fig. 99. The disadvantage of heavy wear and tear, which appears when this system is used in turbine pumps, is certainly very much less serious when atmospheric air is dealt with. Nevertheless, there is a certain loss due to the formation of vortices in the cells of the impeller where the air is confined by a rotating disc on one side and an immovable casing on the other side, and this defect is unavoidable in this otherwise excellent balancing system.

“Balancing by Balancing Piston.—The design which is now practically standard, Fig. 100, is characterized by a continuous flow of air through the impellers on one direction, while the consequent axial thrust is reduced by other means.

“Beyond the last stage there is fixed on the shaft a piston which is of the same diameter as the entrance of the impellers and extends as far as possible axially. It revolves with a very small clearance in a box containing a labyrinth, such as that described above.

“One side of this piston is under the full pressure of the last stage, the other side being connected by a large pipe to the entrance chamber. The effort which the pressures of all the stages exert on the piston area is thus equal to the effort which the pressures of the single stages altogether exert on the single impellers, and as the two forces act in opposite directions the balance is perfect. Here again is another reason for limiting the number of stages that may be coupled together in a single casing, for although it is possible normally to keep the losses caused by the balancing piston of a blower within limits of 1 per cent., this would not be possible if the pressure differences were as great as 50 lb. or perhaps 100 lb. per square inch.

“Stuffing-boxes.—The problem of a reliable, tight stuffing-box, which is so difficult in the design of turbo-pumps, can be most perfectly and easily solved in the turbo-compressor. The first group of a compressor, or the whole of any blower which is of the piston-balance type just described, needs, we might say, no stuffing-box at all, as both free ends of the machine are under atmospheric pressure, and if air should be sucked in around the shafts, no harm would be done, as air is just what the blower requires; only in cases where the blower has to deal with very poisonous or valuable gases would it be necessary to provide a special packing. In all the following casings (that is, in casings containing the high-pressure groups), stuffing-boxes may be wholly dispensed with by using a fully capped bearing, as in Fig. 92. The probability of water mixing with the oil would, of course, forbid this design with any good centrifugal pump or water turbine.”

“Figure 101 shows test curves taken during the practical operation of one of the latest turbine blowers supplied by C. H. Jaeger & Co. to the Grillo Zinc Works, Ltd., Hamborn on the Rhine. The curves show the relation between pressure, power absorbed by the blower spindle, efficiency, and duty at constant running speed. The pressure, horse-power, and efficiency, are ordinates over the respective duties as abscissæ, in like manner to that followed in making these curves for turbine pumps. It is easily seen that over a fairly wide range the pressure and efficiency remain nearly constant, and the regulation of the capacity can therefore be made by simply throttling down the surplus quantity. The speed of revolution need not be altered, and alternating-current motors or an exhaust-steam turbine may readily be used for driving these blowers in their simplest form.

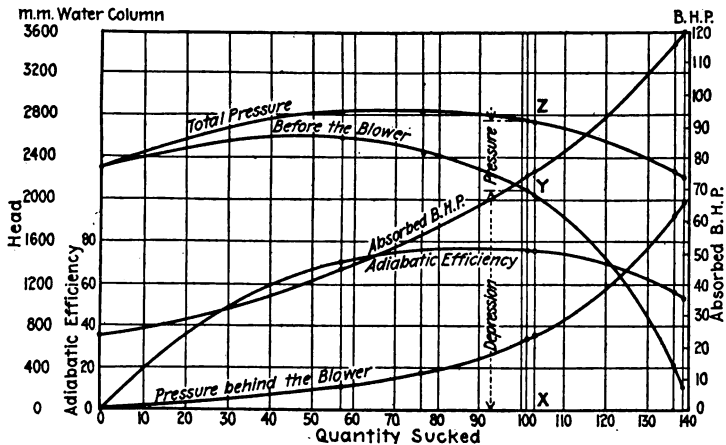

FIG. 101.—Test curves, Jaeger's turbo-blower.

“**Coupling Compressors.**—In some cases, as, for instance, in blast furnaces, it may be necessary to generate an extra high pressure for short periods. Such necessities may arise, for example, if the resistance of the air nozzles or of the column of melting ore is increased. The centrifugal blower running at constant speed would not be able to drive the air through the mains at a pressure much higher than normal. If, therefore, no means for regulating the running speed are available, some arrangement must be supplied such as that furnished by Sautter, Harle and Cie, to the iron works at Chase. Fig. 102 shows how coupling either in parallel or in series is combined with perfect balancing of the impellers.

“Although coupling the stages alternately either in parallel or in series permits us either to deliver a large quantity at normal pressure or a reduced quantity at double that pressure, this mode of regula-

tion is unsuited to a great many cases. For instance, in the majority of chemical processes, the delivery of constant volumes of gas is necessary for the economical working of the process and the uniform quality of the product. One of the best known of these processes is the melting of pig iron in the cupola. The problem of delivering

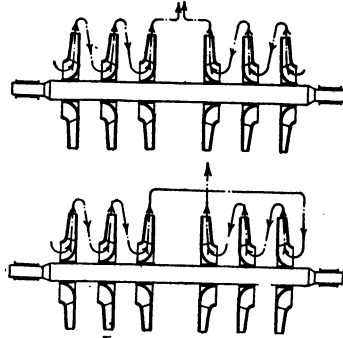

FIG. 102.—Arrangements for coupling turbo blowers.

the constant volume against varying head can be solved only by using varying speeds, but under this condition it can be solved by the turbo-blower with almost unexcelled exactness. The means by which this is effected is an apparatus which has been called by its inventor, Prof. Rateau, the 'Multiplier.'

"**Rateau Multiplier.**—Fig. 103 shows a cross-section of the Multiplier as applied in the well-known turbo-blower plant at

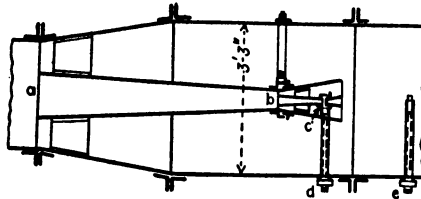

FIG. 103.—Rateau multiplier.

Rothe Erde. The principle is the same as that of the Venturi water meter; that is, by tapering a pipe the velocity with which the gas passes through it is increased as the diameter is narrowed. As no addition or subtraction of energy is made during the passage of gas through the pipe, any increase of velocity must be accompanied by a decrease of static pressure. If the air be tapped from the narrowest and widest points of the tapered pipe, and the tapping pipes be led to opposite sides of a movable piston, it is clear that the difference in static pressure on the two sides of the piston will either move that piston or exert a certain effort on the piston-rod.

“The greater the reduction of cross-section in the tapered pipe is made, the greater becomes the effect exerted through the piston-rod, and the greater also becomes the variation in that effort caused by any increase or reduction of velocity in the main; that is, of the quantity passing through this main per second. Therefore, to obtain a very sensitive piece of apparatus powerful enough to move a governor gearing when the variation in the delivery is but 1 or 2 per cent., it would be necessary to make such a great difference of cross-sectional area that the resistance of the mains would be considerably increased by the throttling effect of the taper.

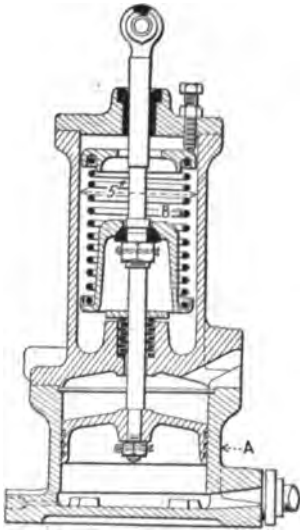

FIG. 104.—Piston controlled by multiplicator.

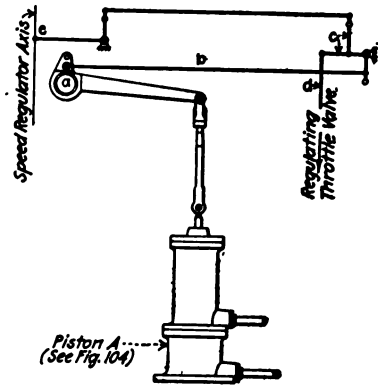

FIG. 105.—Connection between piston and regulators.

“Here the ingenuity of Prof. Rateau’s method appears. He tapers the main but very slightly and inserts at the narrowest end a system of pipes as shown in Fig. 103. At the point *a* the static pressure is already reduced somewhat below that in the normal pressure main. At the point *b* the pressure of the small quantity tapped off at *a* is again decreased. Finally, the static pressure at *c* is in turn much lower than at *b*. The effect of this arrangement is so great that with a velocity of 60 ft. per second in the mains, the difference of static pressure between *a* and *c* was about 6 in. of mercury, while the loss occasioned by the whole installation was at the same moment not more than $3/8$ in. of water column. By putting the two ends of the cylinder *A*, Fig. 104, in connection with the narrowest and widest points of the tapered piping system, a consid-

erable force can be exerted on the spring *B*. It can easily be calculated that a difference of 2 1/2 lb. in total pressure is generated by a variation of about 1 per cent. in the velocity of the air current passing through the mains; that is, when the quantity delivered by the blower varies by about 1 per cent., a force of about 2 1/2 lb. becomes available for moving the regulator.

"Figure 105 gives an idea of the manner in which the gearing was arranged in a special case. The speed regulator and regulating throttle valve of a Parsons steam turbine were influenced simultaneously. In like manner the regulating lever of any driving electric motor can be moved in exact proportion to the momentum of the air piston, as shown in Fig. 103.

"It is very interesting to see how this achievement enabled turbo-blowers of the Rateau system to create an entirely new field for themselves. One of the licensees of Prof. Rateau, the machine-manufacturing establishment of Kuehnle, Kopp & Kausch at Frankenthal, delivered some turbo-blowers for the Anilin and Soda Factory at Baden for the purpose of blowing air through the electric arc in the newly invented process of obtaining nitric acid directly from the atmosphere. These turbo-blowers were to replace reciprocating blowers, which had caused great trouble and expense. It was necessary to connect them with a very large air-tank in order to produce reasonable steadiness of the air current, and when inspection of the reciprocating blowers was necessary, it was impossible except by the skill of very experienced mechanics, and even then only with the greatest risk, to take one of the blowers out of service and at the same time start another without interfering with the continuous current of air. The turbine-blower not only gave an absolutely continuous air current, but proved so safe in operation that no change of blowers was needed during the entire process, which generally lasts uninterruptedly for several months.

"**Mixing Blower.**—This extraordinary success of the turbo-blower impelled the Badische Anilin and Soda Fabrik to order from Kuehnle, Kopp & Kausch another kind of turbo-machine—that is, a mixing blower, which is shown in Fig. 106. Two different gases are drawn by different sets of impellers, keyed on the same shaft, and are delivered to two different delivery pipes. This arrangement has the advantage that owing to the compulsory equality of speed of both impeller groups, the relation between the quantities of the gases continuously delivered is absolutely the same (that is, it is proportionate to the cross-sections of the impellers) providing the resistance remains equal in both delivery pipes. As this last condition cannot be kept uniform during the chemical process, auxiliary throttle valves are inserted in the delivery pipes and worked by two Multipliers. These latter, after careful adjustment,

insure the maintenance of absolutely constant mixing rates between the two deliveries under all conditions. The makers were required to guarantee that the mixing ratio should be kept constant within a margin of 1 per cent., and their machines were so perfectly designed

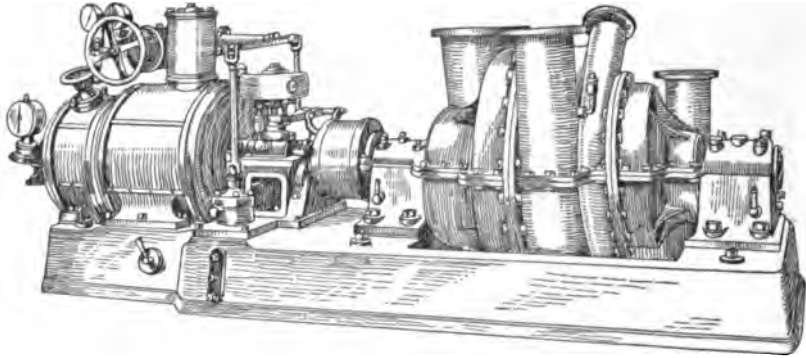

FIG. 106.—Turbo-compressors for mixing air and gas.

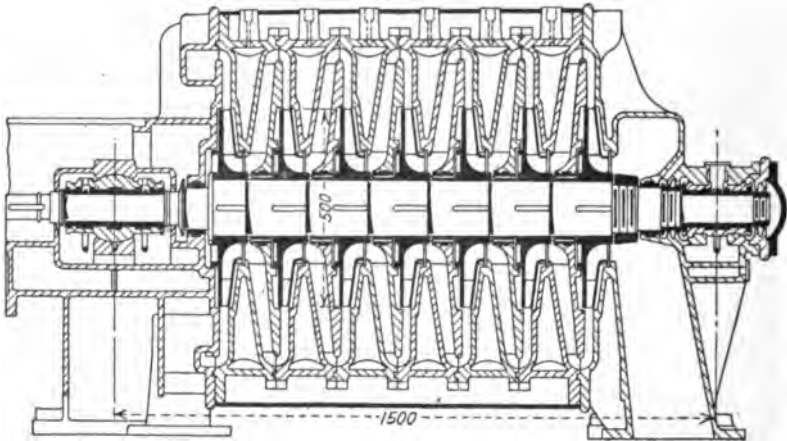

FIG. 107.—Rateau turbo-compressor, 140,000 cu. ft. per hour.

that the Badische Anilin and Soda Fabrik at once began to develop new processes for the electric synthesis of gases, which were made possible only by the new mixing turbo-blower."

The cross-section of a Rateau Turbo-compressor of 140,000 cu. ft. per hour running at 4,600 r.p.m. is shown as Fig. 107.

CHAPTER XII

HYDRAULIC COMPRESSION OF AIR

The method of compressing air by means of falling water, without the use of any other moving part whatever, forms one of the most interesting topics in the subject of air compression.

The large installations in northern Michigan, together with the large compressors of the same type in British Columbia, Quebec and Connecticut, give some idea of the extent to which this very simple method of utilizing the energy of falling water is being applied. All of these installations have been completed within very

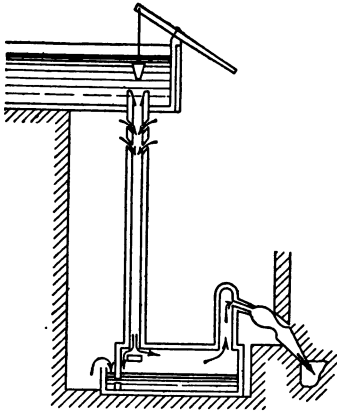

FIG. 108.—The trompe.

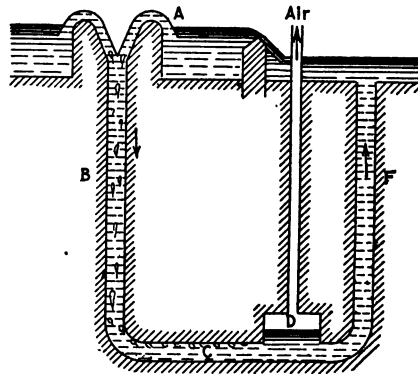

FIG. 109.—Frizell's hydraulic compressor.

recent years and their success gives promise of many more such plants being planned.

Trompe.—One of the oldest forms of compressing air is by means of a trompe or water bellows, a device of historic interest, in which water was lead from a higher to a lower level through a pipe or bamboo pole with openings in the side through which air entered and mingled with the descending water and was later trapped from it, as shown in Fig. 108, for use in forges.

A great many improvements have been made on this early apparatus and quite distinct types developed from it.

Frizell's Compressor.—One of these is shown in Fig. 109, the invention of J. P. Frizell of Boston, Massachusetts. This device utilizes an inverted syphon having a horizontal passage C between

the two legs, *B* and *F*. A stream of water is led into the upper end of the longer leg *B* and at the top of the horizontal passage *C* between the two legs of the syphon, an enlarged chamber, *D*, is constructed in which the air separates from the water. The water freed from the air passes up the shorter leg, *F*, of the syphon to the tail race. The pressure of air accumulating in the chamber is determined by the height of water in the shorter leg.

This application of carrying upward the water after the air is separated from it seems to have been original with Mr. Frizell, and in this respect his device differs from the old trompe.

Mr. Frizell made two working models of this type of apparatus. In the first one, the legs of the syphon were 3 in. in diameter, the head of water being 25 in. and an efficiency of 26 1/2 per cent. was obtained. A larger apparatus was then constructed at the Falls of St. Anthony on the Mississippi River a few miles above St. Paul; the longer leg of the syphon in this plant was 15×30 in. and the shorter leg of the syphon 24×48 in. in section; the height of water above the air chamber was 29 ft. The head in feet varied from 0.98 to 5.02; the first head being just sufficient to cause a flow through the pipes. With the working head changed from 2.54 ft. to 5.02 ft., the efficiency varied from 40.4 per cent. to 50.7 per cent., the quantity of water in these cases varying from 5.92 to 11.89 cu. ft. per second.

Mr. Frizell estimates from the experiments he has made that with a shaft 10 ft. in diameter, a depth of 120 ft. and a fall of 15 ft., the efficiency would be 76 per cent.; and with a head of 30 ft. and a fall of 230 ft. the efficiency would be 81 per cent.

Mr. Frizell's first experiments involved a large outlay in cost of plant and were not entirely satisfactory; but where there is a moderate water fall and plenty of water, this is no doubt a very simple method of compressing air.

This system is applicable to either high or low falls and although no installations of this type of air compressors were made until a number of years after Mr. Frizell's patents were obtained, the fact that he is the pioneer in this line entitles him to a great deal of credit.

The following explanation of this system is taken from *The Railway and Engineering Review*, Sept. 17, 1898.

"The general principles underlying this method of compression is familiar to most in one form or another. For instance, it is well known how readily water breaks into foam, which is due to its being

impregnated with air in minute bubbles. Since bubbles rise in water at a velocity depending on the size of the bubble, it is obvious that air drawn into a current of water moving downward with a velocity in excess of that at which the bubbles rise will be carried down and subjected to a pressure corresponding to the depth attained, and moreover the compression will take place isothermally, a process which is not accomplished by any method of piston compression. If the direction of the water be then altered to a horizontal one, the air will rise in a few seconds to the top of the passage and accumulate in a suitable chamber under the desired pressure. The length of the horizontal tunnel will be controlled by the necessity of placing the entrance to the air chamber far enough from the descending branch to admit of the complete escape of the air bubbles.

“A method of introducing air into the descending column of water is to surround the shaft with a bulkhead of masonry, over which

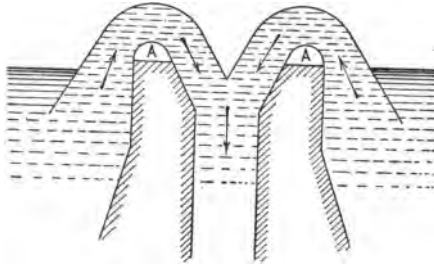

FIG. 110.—Syphon bulkhead.

the water is led in a covered channel, the bottom of which rises a little above the highest level of the water. This forms a syphon as shown in Fig. 110.

“At the point *A* the pressure within the syphon is less than that of the external air, and the latter will flow in through any opening. This is evident, because the flow of water depends upon the syphon principle. This space *A* extends around the masonry bulkhead and is in communication with the atmosphere. It is also connected with a pump for the purpose of removing any water that may collect in it, the amount of air being regulated by opening or closing holes in chamber *A*.”

Baloche and Krahnass Compressor.—Another device, shown in Fig. 111, differs somewhat from that of Mr. Frizell. It was invented by A. Baloche and A. Krahnass in 1885 and consisted of a syphon, *B*, carrying water from an upper to a lower reservoir, the lower end of the syphon being projected through an inverted vessel, *R*, placed nearly at the bottom of the second reservoir. Just beyond the bend

in the syphon and in line with the axis of its longer leg, an air pipe, *T*, projected into the descending leg of the syphon. This entrained the air with the descending column and carried it down into the inverted chamber, *R*, from which the air escaped at the top, while the water passed out from the bottom into the lower reservoir. This apparatus produced pressure on the air in the top of the inverted chamber due to the height of the water column upon it.

Arthur Compressor.—Another device, shown in Fig. 112, patented by Thomas Arthur in 1888, differs from the last in having a stream

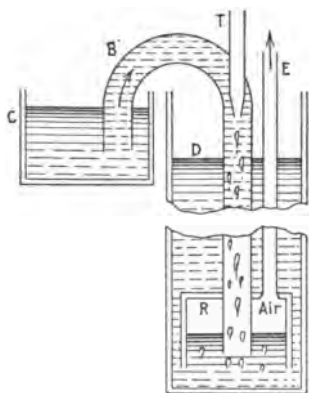

FIG. 111.—Baloche and Krahnass's hydraulic compressor.

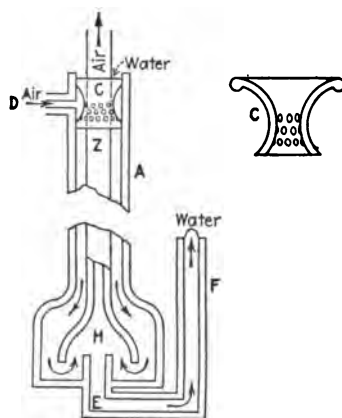

FIG. 112.—Arthur's hydraulic compressor.

of water led directly into the top of the vertical pipe *A*. Inserted into the mouth of this pipe is a double cylindrical cone, *C*, forming an annular air passage between it and the walls of the pipe *A*. Owing to the increase in the velocity of the water passing through the narrow throat of the double cone, air is inhaled through the pipe *D*, through the annular space mentioned and through perforations in the lower cone and is entrained with the falling water.

Through the down-flow pipe *A* rises a vertical delivery pipe, *Z*, for the compressed air, having its lower end, *H*, enlarged and open at the bottom. Projecting upward into this enlarged air-delivery pipe is a water escape pipe, *F*, through which the water passes after parting with the air. The escape pipe is in the form of an inverted syphon and maintains on the air in the delivery pipe *Z* a pressure due to the elevation of the water at the discharge point above the air line in the large end of the delivery pipe.

Taylor Compressor.—The hydraulic compressor system of Mr. Taylor is shown by Fig. 113. The large recent installations referred to are principally based upon his patents.

With Taylor's system a series of small air pipes placed vertically in the upper end of the falling column of water introduce the air into the water. The compressed air and water are separated at the bottom of the shaft.

Mr. Taylor seems to have been the first to introduce the plan of dividing the air inlets into a great number of small openings evenly distributed over the area of the water inlet.

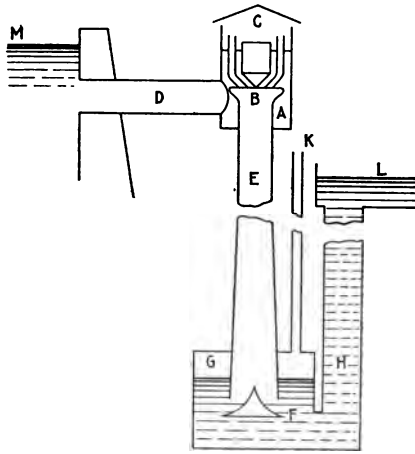

FIG. 113.—Taylor's hydraulic compressor.

In the figure shown, these air tubes are represented at *C*, all terminating at the conical entrance *B* to the down-flow pipe *H*. The water supply is furnished to this down-flow pipe through a flume *D*. As the water falls it draws air through the small tubes, carrying it down to the separating tank *G*, where it is liberated at a pressure depending on the weight of the water in the vertical pipe *H*.

The compressed air is then conducted through the pipe *K* to the place to be used. The distance from *M* to the tail race *L* represents the height or fall of water that is available.

Taylor at first seems to have attempted to utilize centrifugal action in causing the separation of the air and water in the large chamber at the bottom, but afterward abandoned this scheme and used instead forms of deflector plates in combination with a gradually enlarging section of the lower end of the down-flow column in

order to decrease the velocity of the air and water and cause the water to part more readily from the air.

The position of the hopper or frame carrying the air inlet tubes regulates the amount of water that is admitted to the vertical pipe. The quantity of air regulates itself and is neither more nor less than the given quantity of water can carry. If the descending column is so loaded with air that it does not preponderate sufficiently over the ascending column, the water in the former will rise, the commotion will diminish and less water will enter. In the contrary case the water falls, commotion increases and more air is taken in.

Taylor Compressor at Magog, Quebec.—The first one of these compressors on the Taylor principle was installed at Magog, Quebec, to furnish power for the print works of the Dominion Cotton Mills Company. The head of water is 22 ft., the down-flow pipe is 44 in. in diameter and extends downward through a vertical shaft 10 ft. in section and 128 ft. deep. At the bottom of the shaft the compressor pipe enters a large tank 17 ft. in diameter and 10 ft. high, which is known as the air chamber and separator.

A series of very careful experiments have been conducted at the Magog plant by Professor Kennedy and others; and it has been demonstrated that with a head of $19 \frac{1}{2}$ ft. of water using 4,292 cu. ft. of water per minute, the equivalent of 1,148 cu. ft. of free air per minute was recovered at a pressure of 53.3 lb. showing that of a gross horse-power of 158.1, 117.7 h.p. of effective work was used in compressing air, giving an efficiency of 71 per cent. which is very satisfactory.

This compressed air was then used in an old Corliss engine, without changing the valve gear in any way from what it was when adjusted for steam, and 81 h.p. was recovered, showing a total of work recovered from the falling water of 51.2 per cent. When the compressed air was heated to 276° before being used in the engine, 111 h.p. was recovered. The heating required 115 lb. of coke per hour, equal to about 23 h.p. The efficiency, therefore, including the falling water and the fuel consumed, was $61 \frac{1}{2}$ per cent. It has been calculated from other experiments that if the compressed air had been heated to 300° the total efficiency secured would have been $87 \frac{1}{2}$ per cent.

When it is considered that a good water turbine will give an efficiency of 85 per cent. and that part of the power developed in the turbine will be lost through transmission before the power is available, it is evident that this system is a very efficient method

of generating and transmitting power. For if the efficiency of the turbine is 85 per cent. and that of the system that is used for converting the power in the turbine into a more available form 80 per cent., the total efficiency of the system will be 0.80×0.85 or 68 per cent.

This shows the immense importance of this device. Its field of usefulness is certainly a large one.

Taylor Compressor at Ainsworth, B. C.—Figure 114 illustrates a sketch of the upper part of the Taylor Hydraulic compressing plant at Ainsworth, B. C., which is quite unique in that it did not require the sinking of a very deep shaft. The apparatus is constructed against the vertical wall of the canyon in the rugged mountain district in which it was built. The plant is located on Coffee Creek to the south of Ainsworth and about $2 \frac{1}{2}$ miles from the principal mines to which it supplies compressed air. The creek has a flow varying from 2,500 cu. ft. per minute to several thousand, and the flume used is stave barrel construction, round steel bands being bolted around it every 3 ft. The flume is 1,350 ft. in length, 5 ft. in diameter in the clear, the available head at the compressor being $107 \frac{1}{2}$ ft. The

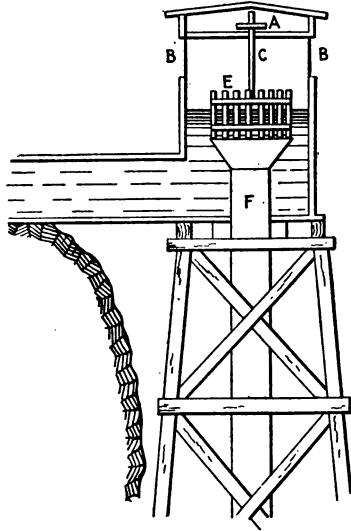

FIG. 114.—Taylor's compressor at Ainsworth, B. C.

water at the compressor tower is received in a wooden tank 12 ft. in diameter and 20 ft. in height. A down-flow pipe passes from the water level through the bottom of this tank down perpendicularly and at the creek level a shaft extends to a depth of 210 ft., making a total vertical height to the shaft of over 300 ft.

This down-flow pipe, which is 2 ft. 9 in. in diameter outside, is also of stave construction throughout, the bands being placed from 6 in. to 3 ft. apart, depending on the pressure to which a particular section is subjected.

This terminates in a great bell-shaped chamber at the bottom of the shaft 17 ft. in diameter and 17 ft. high, the bottom of this chamber being about 2 ft. above the bottom of the shaft, thus allow-

ing the water to pass out and up the shaft to the tail race. A deep circular groove was dug in the bottom of the shaft to aid in separating the air from the water.

As the distance from the water level of the air chamber to the tail race is about 200 ft., the pressure on the air is about 87 lb. per square inch.

The air is conducted from the compressor through a 9-in. pipe which supplies compressed air through several branches to over 15 mining properties. The total length of pipe is over 2 miles. A pipe reaches from the surface of the creek level—that is, the tail race—to the dividing line between the air and water of the large chamber at the bottom; so that if more air is being compressed than is being used, the water line in this chamber will be lowered and the surplus air escape, while if the pressure of air falls, the escape pipe will be closed.

The actual effective head of water in the apparatus is 107 1/2 ft. and if a turbine had been used, with an efficiency of 75 per cent. the available horse-power generated would amount to 620.

This installation has cost in the neighborhood of \$60,000, including incorporation, water-power, development and pipe line. Of this investment, \$20,000 will cover the pipe-line cost, \$10,000 the water-power improvements, and \$30,000 the compressor cost. This last item was unusually high because of the extremely hard foundation through which the shaft was sunk.

Taylor Compressor at Victoria Mine, Mich.—In 1906 a large plant of this type was installed at Victoria Copper Mine near Rockland, Ontonagon County, Michigan, which consisted of three compressing units with a total capacity of from 34,000 to 36,000 cu. ft. of free air per minute. A series of tests made on a single intake head by Prof. F. W. Sperr, gave the following results:

TABLE X.—AIR MEASUREMENTS

Square feet area	Velocity feet per second	Cubic feet per minute	Absolute pressures		Horse-power
			Free air, pounds	Compressed air, pounds	
4	44.09	10,580	14	128	1,430
4	49.74	11,930	14	128	1,623
4	38.50	9,238	14	128	1,248

TABLE XI.—WATER MEASUREMENTS

Flume area	Velocity feet per second	Cubic feet per minute	Head, feet	Horse-power	Efficiency, per cent.
71.75	3.033	13,057	70.5	1,741	82.17
67.03	3.684	14,820	70.0	1,961	82.27
72.16	2.936	12,710	70.6	1,700	73.50

Phenomena of Hydraulic Air Compression.—There are several phenomena in connection with this method of compressing air that at first thought seem paradoxical.

In compressing air by hydraulic means, the air becomes *drier* during the compression, but no matter what may be its initial condition as to humidity at the end of compression it will, in all probability, be saturated with moisture.

Air almost always contains moisture. Its capacity for moisture is determined by the combined conditions of pressure and temperature to which it is at the time subjected.

Changes, either of pressure or of temperature, immediately change the capacity of air for water, and if the free air is saturated with moisture its capacity for water will be reduced whenever the pressure is increased or the temperature decreased, and in consequence water will be precipitated.

When air is compressed by hydraulic means, isothermal compression is secured and, generally speaking, at uniform temperature a given *volume* of air implies a capacity for a certain weight of water whether the air is at a pressure of one or one hundred atmospheres, but if the air is compressed through a range from 1 to 100 atmospheres, its volume will be reduced, if the compression is isothermal, to $\frac{1}{100}$ the original volume, and in consequence $\frac{99}{100}$ of the weight of moisture it originally held will be precipitated. The air is still saturated, but the total weight of water held in suspension has been reduced. That is, this method of compression has reduced the weight of moisture present in the air and hence dried it, but at the end of compression the air is saturated with moisture.

Another interesting phenomenon in connection with this type of compressor has recently been brought to light. It has been found that air compressed by this method contains less oxygen than free

air of the atmosphere and in consequence its use in mines is not as beneficial as air from other types of compressors.

It will be observed that, with this construction, the material used for the down-flow pipe need only be of sufficient strength to carry the weight of water and pressure generated in the working head of the water-power, as once it reaches the tail race level the internal pressure is gradually neutralized from that point down by the pressure in the return water surrounding the down-flow pipe; so that any pressure almost may be reached without increasing the strength of the down-flow pipe. The material for the down-flow pipe may be iron or wood hooped with iron, and the shaft may be constructed of inexpensive timber as it is preserved by being constantly in the water.

By this method, low falls, otherwise useless, are made available and the same pressures can be obtained as from high falls, the horse-power being determined by the diameter of the down-flow pipe, and the height and volume of water in fall, while the pressure depends solely upon the depth of the well or shaft; therefore, any desired pressure can be obtained.

Briefly stated, the air is compressed by the direct pressure of falling water without the aid of any moving mechanism and practically without expense for maintenance or attendance after installation.

By this system any fall of water varying in working head may be utilized, any pressure required can be produced and uniformly maintained up to the capacity of the water-power, delivering the compressed air at the temperature of the water.

This drying of the air and the fact that practically isothermal compression is secured, form the great advantages of this system of air compression. The initial cost need not be excessive, and as the cost of attendance is slight, for certain purposes the method is ideal. Its field of operation is quite broad, as a high fall of water is not essential, for any desired pressure can be obtained from any fall, the capacity being determined by the power available in the water fall.

Losses of Hydraulic Compression.—The losses inherent in this method of compression are: (1) The head expended in impregnating the water with air. This usually amounts to about 1 ft.

(2) A loss which may be called the slip due to the velocity with which the bubbles tend to rise. It is obvious that the rise of bubbles during the decent of the water is a lost motion which deducts from

the efficiency of the system and in addition there is a head consumed in friction.

(3) A loss due to the increasing solution of the air in the water with the increasing pressure as the water and air descend.

This air does not separate from the water in the lower chamber but is eliminated in the ascending shaft in the same order that it is dissolved in the descending shaft. The escaping air in the ascending shaft aids the movement of the water and this partly balances the loss in the descending column.

There are on the market to-day small hydraulic air compressors for furnishing compressed air in small quantities for dental and other purposes. They can be operated by water pressure from any water-works supply and on this account are particularly adapted for such purposes.

CHAPTER XIII

EFFECT OF ALTITUDE AND COMPRESSOR TESTS¹

As the density of the atmosphere decreases with the altitude, a compressor located at a high altitude will take in a smaller weight of air at each stroke, that is, if the compressor is located at a high altitude, the air is taken in at a lower pressure and in consequence the early part of the compression stroke is occupied in compressing the air from this lower density up to a standard atmospheric pressure at the sea-level. The reduction of pressure at the inlet would, of course, affect the power expended in compressing the air, but the decrease in power required does not vary in the same ratio as the decrease in capacity. For this reason compressors to be used at high altitudes should have the steam and air cylinders properly proportioned to meet the varying conditions at different levels.

Effect of Altitude on Capacity.—This matter is of special importance in connection with mining operations, because of the large number of mines situated in elevated mountain regions. The rated capacities of compressors, in cubic feet of air, as given in the makers' catalogues, are for work at normal atmospheric pressure, and due allowance must be made for decreased output at elevations above sea-level. This reduction in output, which is usually also tabulated in handbooks and catalogues, should receive due consideration in order to avoid serious errors. For example, the volume of compressed air delivered at 60-lb. pressure, at 10,000 ft. elevation is only 72.7 per cent. of the volume delivered at the same pressure by the same compressor at sea-level. In other words, a compressor which at sea-level will supply power for 10 rock-drills, will at an elevation of 10,000 ft. furnish air for only 7 drills.

Effect of Altitude on Power.—The foregoing statement relates only to the volumetric capacity of the compressor. It must be remembered that the heat of compression increases with the ratio of the final absolute pressure to the initial absolute pressure. As this ratio increases with the altitude, more heat will be generated by compression to a given pressure at high altitudes than at sea-level. This additional heat temporarily increases the pressure of the air in the cylinder while under compression, and more power is therefore re-

¹ Peele, Compressed Air Plant.

quired to compress and deliver a given quantity of air. The corresponding loss of work, due to the subsequent cooling of the air in receiver and piping, also increases with the altitude.

Relation between Altitude and Volume.—Contrary to a common impression, the volume of air delivered by a given compressor does not bear a constant ratio to the barometric pressure, but at different altitudes this volume decreases slower than the barometric pressure. This relation may be shown as follows: Two ideal indicator cards are represented in Fig. 115, one of a compressor working at sea-level with

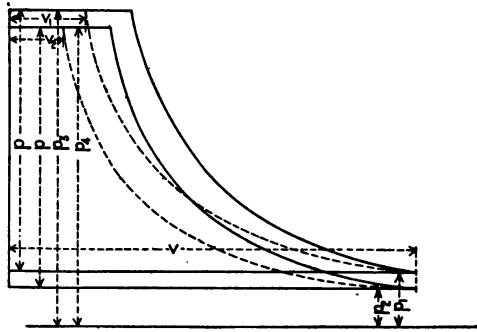

FIG. 115.—Effect of altitude.

an initial pressure P_1 , the other at an altitude with a lower initial pressure P_2 . The initial volume V and the final gage pressure P are the same for both compressors, P_3 and P_4 being the respective final absolute pressures. V_1 and V_2 are the final volumes, corresponding to the dotted isothermal curves, these volumes being taken as the basis because they are those to which the compressed air will eventually shrink on losing the heat of compression. From the theory of air compression,

$$VP_1 = V_1P_3, \text{ or } \frac{V}{V_1} = \frac{P_3}{P_1} \tag{1}$$

and
$$VP_2 = V_2P_4, \text{ or } \frac{V}{V_2} = \frac{P_4}{P_2} \tag{2}$$

But since $P_3 = P_1 + P$, and $P_4 = P_2 + P$, equations (1) and (2) may be written:

$$\frac{V}{V_1} = \frac{P_1 + P}{P_1} = 1 + \frac{P}{P_1} \tag{3}$$

and
$$\frac{V}{V_2} = \frac{P_2 + P}{P_2} = 1 + \frac{P}{P_2} \tag{4}$$

Dividing equation (3) by equation (4)

$$\frac{V_2}{V_1} = \frac{1 + \frac{P}{P_1}}{1 + \frac{P}{P_2}}, \text{ or } V_1 : V_2 :: 1 + \frac{P}{P_2} : 1 + \frac{P}{P_1} \quad (5)$$

This gives an expression for the ratio between pressure and volume at sea-level and for any altitude above sea-level, of which the corresponding barometric pressure is P_2 . Thus, let $P_2 = 10$ lb., $P = 90$ lb., and $V_1 = 0.1404$ cu. ft. By substituting these quantities in equation (5), V_2 is found to be 0.0999, or approximately 0.1 cu. ft.

In Table XII, columns 4 and 5, are given the relative volumetric outputs, at gage pressures of 70 and 90 lb. of a compressor working at different altitudes, the figures being percentages of the normal output at sea-level. These percentages have been derived by Mr. F. A. Halsey from equation (5), a constant loss of initial pressure of c.75 lb. being assumed to allow for the resistance presented by the inlet valves, to which reference has been made in another chapter. That is, for practical purposes the sea-level atmospheric pressure is taken as 14, instead of 14.7 lb. The other columns show the mean effective pressures and indicated horse-powers, corresponding to different altitudes, up to 15,000 ft., which will be found convenient for reference. It should be noted from the figures in columns 4 and 5, which are for the ordinary range of pressure employed in mining, that, though there is a difference of 20 lb. between the two gage pressures, yet the outputs at different altitudes vary only by a few thousandths and may often be neglected.¹ Wide differences, however, occur in the columns of mean effective pressures and horse-powers.

Owing to the increase of piston displacement per indicated horse-power, as shown in columns 8 and 9 of the table, some builders make the air cylinders of compressors for mountain work of larger diameter for the same size of steam cylinder than those for sea-level service. As against the losses of the air end of the compressor at high altitudes, there is some gain in mean effective pressure of the steam cylinders, because the exhaust takes place against lower atmospheric pressure. The same is true in part of the air exhaust of machines using the compressed air. But the

¹ Attention may be called to the fact that for this reason, in compressor-builders' catalogues, no account is taken of the gage pressures in tables of compressor capacities at altitudes.

resultant of these gains is small and cannot be given much weight in offsetting the losses.

TABLE XII

Altitude, feet	Barometric Pressure		Relative out- put for gage pressure		M.E.P. for gage pres- sure		Cubic feet piston dis- placement per indicated horse-power for gage pressure		Cubic feet compressed air per indicated horse-power for gage pressure	
	Inches mer- cury	Pounds per square inch								
			70 lb.	90 lb.	70 lb.	90 lb.	70 lb.	90 lb.	70 lb.	90 lb.
I	2	3	4	5	6	7	8	9	10	11
0	30.00	14.75	1.000	1.000	33.1	38.2	6.93	5.99	1.144	0.801
1,000	28.88	14.20	0.967	0.966	32.6	37.6	7.03	6.09	1.123	0.787
2,000	27.80	13.67	0.935	0.933	32.1	36.9	7.15	6.20	1.103	0.773
3,000	26.76	13.16	0.904	0.900	31.5	36.3	7.27	6.31	1.084	0.759
4,000	25.76	12.67	0.873	0.869	31.0	35.6	7.39	6.43	1.065	0.746
5,000	24.79	12.20	0.843	0.839	30.5	35.0	7.51	6.55	1.046	0.733
6,000	23.86	11.73	0.813	0.809	30.0	34.3	7.65	6.67	1.028	0.720
7,000	22.97	11.30	0.785	0.780	29.4	33.7	7.80	6.79	1.011	0.708
8,000	22.11	10.87	0.758	0.751	28.9	33.1	7.94	6.92	0.994	0.695
9,000	21.29	10.46	0.731	0.723	28.3	32.5	8.09	7.06	0.976	0.683
10,000	20.49	10.07	0.705	0.696	27.8	31.8	8.24	7.20	0.959	0.670
11,000	19.72	9.70	0.680	0.671	27.4	31.2	8.39	7.34	0.942	0.658
12,000	18.98	9.34	0.656	0.647	26.9	30.6	8.54	7.49	0.925	0.646
13,000	18.27	8.98	0.632	0.623	26.3	30.0	8.71	7.64	0.908	0.635
14,000	17.59	8.65	0.608	0.600	25.8	29.4	8.88	7.80	0.891	0.624
15,000	16.93	8.32	0.585	0.576	25.3	28.8	9.06	7.96	0.875	0.613

The relation between compressor output and barometric pressure may be expressed simply in another way. Take the case of two compressors of the same size, one operating under an atmospheric pressure of, say, 14 lb. and the other at 10 lb. (corresponding approximately to an altitude of 10,000 ft.). If the first compressor is producing 6 compressions, the final absolute pressure will be $14 \times 6 = 84$ lb. or about 70 lb. gage pressure. To produce the same gage pressure, the other compressor must work to an absolute pressure of $70 + 10 = 80$ lb., the number of compressions corresponding to which is $\frac{80}{10} = 8$. From each cubic foot of free air the compressor will produce $\frac{1}{6}$ of a cu. ft. of compressed air, and the second compressor, $\frac{1}{8}$ cu. ft. Hence, the ratio of the respective outputs of the two compressors will be $\frac{1}{8} \div \frac{1}{6} = \frac{3}{4}$ or 0.750. As com-

pared with this, the ratio of the respective barometric pressures is $\frac{10}{14} = 0.714$.

COMPRESSOR TESTS

To indicate the observations required to secure the data for the complete test of a compressor, together with the deductions from the observed data, the following record of the test of a compound, two-stage Nordberg compressor, at the mines of the Tennessee Copper Co., will be found useful.¹ It will be noted that items 28, 29 and 32 to 35 are necessary in this case, because the boiler plant supplied steam for the hoisting engine and an independent condenser, as well as for the compressor. Though the hoist was not running, steam was passing continuously to the jackets of the cylinders. The same conditions would often be met in other tests. The boiler-feed water was taken from a wooden tank, and during the run this water was supplied from two barrels on scales set temporarily over the tank. The water of condensation from steam jackets and reheater was drawn off continuously and also weighed. The calorimeter tests were made with a Peabody throttling calorimeter. Eight sets of indicator cards were taken during the 8-hour test, at hourly intervals.

ITEMS OF COMPRESSOR TEST

Altitude, 1,800 feet

1. Date of test, February 16, 1902.	
2. Duration of test, hours.....	8
3. Diameter of high-pressure steam cylinder (steam jacketed), inches.....	14
4. Diameter of low-pressure steam cylinder (steam jacketed), inches.....	28
5. Diameter of low-pressure air cylinder, inches...	24 1/2
6. Diameter of high-pressure air cylinder, inches.	15 3/8
7. Stroke of all pistons, inches.....	42
8. Diameter of piston-rods, inches.....	2 11/16
9. Revolutions of engine, average per minute....	90
10. Piston speed per minute, feet.....	630
11. Steam-gage pressure, average.....	145.9
12. Temperature of steam in steam-pipe, average degrees Fahrenheit.....	364

¹ Abstracted from an article by J. Parke Channing, *Mines and Minerals*, May, 1905, p. 475.

13. Steam pressure in reheating receiver, average pounds.....	8
14. Vacuum in condenser, average inches.....	25.66
15. Air pressure in intercooler, average pounds....	22.63
16. Air pressure in receiver, average pounds.....	79.3
17. Temperature of air at intake, average degrees Fahrenheit.....	65.0
18. Temperature of air leaving low-pressure cylinder, average degrees Fahrenheit.....	211.5
19. Temperature of air leaving intercooler, average degrees Fahrenheit.....	78.5
20. Temperature of air leaving high-pressure cylinder, average degrees Fahrenheit.....	240.0
21. Indicated horse-power in high-pressure steam cylinder, average.....	140.12
22. Indicated horse-power in low-pressure steam cylinder, average.....	153.03
23. Indicated horse-power in both steam cylinders, average.....	293.15
24. Indicated horse-power in low-pressure air cylinder, average.....	143.79
25. Indicated horse-power in high-pressure air cylinder, average.....	135.02
26. Indicated horse-power in both air cylinders, average.....	278.81
27. Feed-water weighed to boilers, pounds.....	43,343
28. Re-heater and jacket water from compressor, weighed, pounds.....	4,081
29. Average temperature of re-heater and jacket water, degrees Fahrenheit.....	356.7
30. Total heat in 1 lb. of steam at 356.7° F., heat units.....	1,190.7
31. Total heat in 1 lb. of water at 356.7° F., heat units.....	328.9
32. Equivalent credit for re-heater and jacket water, pounds.....	1,127.00
33. Water weighed from condensation in hoisting-engine jacket, pounds.....	1,781.00
34. Steam used to run condenser, pounds.....	4,320.00
35. Total credits to feed-water, pounds.....	7,228.00
36. Total feed-water charged to engine, pounds...	36,115.00
37. Moisture in steam shown by Peabody calorimeter, per cent.....	1.30
38. Credit for moisture in steam, pounds.....	473.00
39. Total steam charged to engine, pounds.....	35,642.00
40. Dry steam per hour charged to engine, pounds..	4,455.00
41. Steam consumption per indicated horse-power per hour, pounds.....	15.19

42. Guaranteed steam consumption per indicated horse-power per hour, at 92 revolutions per minute, pounds.....	14.00
43. Excess of steam consumption per indicated horse-power per hour over guarantee, pounds	1.19
44. Theoretical delivery of free air per minute at 90 revolutions, cubic feet.....	2,037.8
45. Slip of air (percentage).....	3.0
46. Actual slip of air per minute, cubic feet.....	61.1
47. Actual delivery of free air per minute, average cubic feet.....	1,976.7
48. Theoretical horse-power required to compress and deliver actual delivery of air at receiver pressure by adiabatic compression.....	306.53
49. Theoretical horse-power required to compress and deliver actual delivery of air at receiver pressure by isothermal compression.....	229.00
50. Actual horse-power shown by air indicator cards.....	278.81
51. Actual horse-power shown by steam indicator cards.....	293.15
52. Actual horse-power consumed by friction of engine.....	14.34
53. Efficiency ratio between steam and air cylinders, per cent.....	95.1
54. Efficiency ratio between steam and air cylinders guaranteed by builder, per cent.....	87.00
55. Efficiency of steam, or ratio of steam indicated horse-power to theoretical air indicated horse-power, isothermal compression, per cent....	78.1

One of the combined indicator cards, from which the averages in items 21 to 26 were calculated, is shown in the upper part of Fig. 116.

A series of tests were made in 1909 by Richard L. Webb, consulting engineer, of Buffalo, N. Y., on a large number of compressors in a well-known Canadian mining district. In conducting these tests, Mr Webb had access to plants which have been in operation for a year or more under normal working conditions, and his results are of value not only to users of air compressors, but also to the manufacturers. As a rule, the plants tested were in the care of competent machinists and in good running order, so that the results obtained may be taken as representing a fair average of current practice in the United States and Canada. The results of a few of these tests are given here to show the importance of determining the actual efficiency of air compressors when working under the conditions prevailing in most mines.

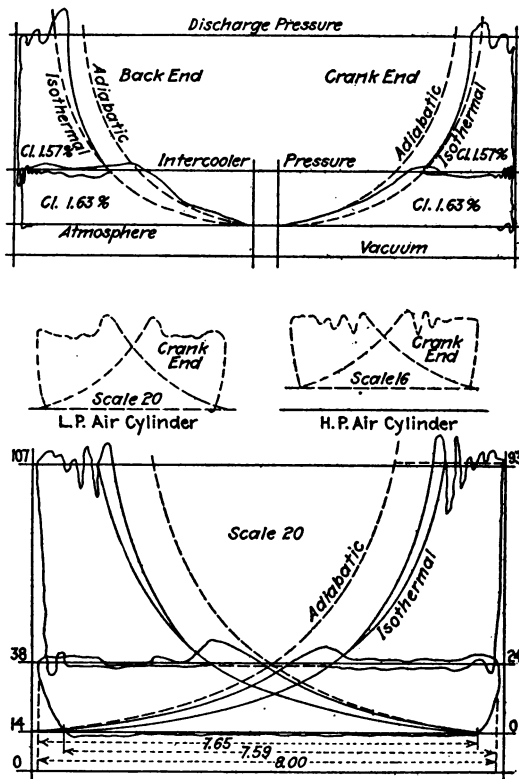

FIG. 116.—Combined cards from two-stage compressors. Upper cards from Nordberg compressor. Lower cards from Ingersoll-Rand "Imperial Type 10" electrically driven compressor. Air cylinders 23" and 14" x 20".

Revolutions per minute.....	187
Piston speed, feet per minute.....	623.3
Discharge air pressure, pounds.....	93
Intercooler pressure, pounds.....	24
Volumetric efficiency (from card).....	95.3%
I. H. P. of low-pressure cylinder.....	132
I. H. P. of high-pressure cylinder.....	120.8
Total I. H. P.....	252.8
Free air delivered per minute, cubic feet (from card)...	1706
Efficiency compared with adiab.....	97.2%
Efficiency compared with isoth.....	84 %

Mode of Conducting the Tests.—The following plan was employed in each case. First, a boiler test was run for not less than two weeks, the coal being carefully weighed, the boiler feed-water measured,

and the total revolutions of the compressor recorded by a revolution counter. From these data the cost per boiler horse-power and the average speed of the compressor were determined. Second, the compressor was operated at various speeds over its entire range. By means of a meter installed in the steam-pipe near the throttle, the total steam consumed, in pounds per hour, was measured. Indicator cards were taken on all cylinders, together with temperatures at the air inlet, intercooler, and discharge. To measure the actual volume of air delivered, a meter was placed in the discharge pipe outside of the receiver. A number of simultaneous readings on all instruments were taken at each speed. From these were calculated the total horse-power of the steam and air cylinders, the steam consumption, and the total piston displacement per minute.

The air and steam meters were of the Dodge type, as modified by the General Electric Company, and were operated by their expert sent for this purpose. The indicators were of the Roberts-Thompson and the American-Thompson make, which are well known and generally accepted as standard. Their springs were calibrated by a standard gage.

Results of the Tests.—As was to be expected, the friction loss was found to be only a small item in the total. The other losses, which are frequently overlooked or disregarded, played a large part in cutting down the efficiency. The capacity of air compressors is usually rated according to the volume of the cylinders. On this basis, the mechanical efficiency only is given. For example, if the horse-power of the air cylinder is 100 h.p. and the horse-power of the steam cylinder 110, the efficiency of the compressor is rated as 91 per cent. This rating disregards the losses due to adiabatic compression, heating of the cylinder and friction of the inlet and delivery valves. The tests show the friction loss of the engine itself to be usually not less than 10 per cent., and often considerably larger. Losses from the other causes mentioned were found to range from 30 per cent. up.

As Mr. Webb is not at liberty to disclose the identity of the particular plants at which the tests were made, each test has been designated by a number.

Test of Plant Number One.—This consists of three 125 h.p. return tubular boilers (one being held in reserve), supplying steam for a cross-compound condensing air compressor of standard make. The steam cylinders have Meyer valve gear and are 16 in. and 28 in. diameter by 24 in. stroke. The two-stage air cylinders are 28 in.

and 18 in. by 24 in. From a two weeks' run the following results were obtained:

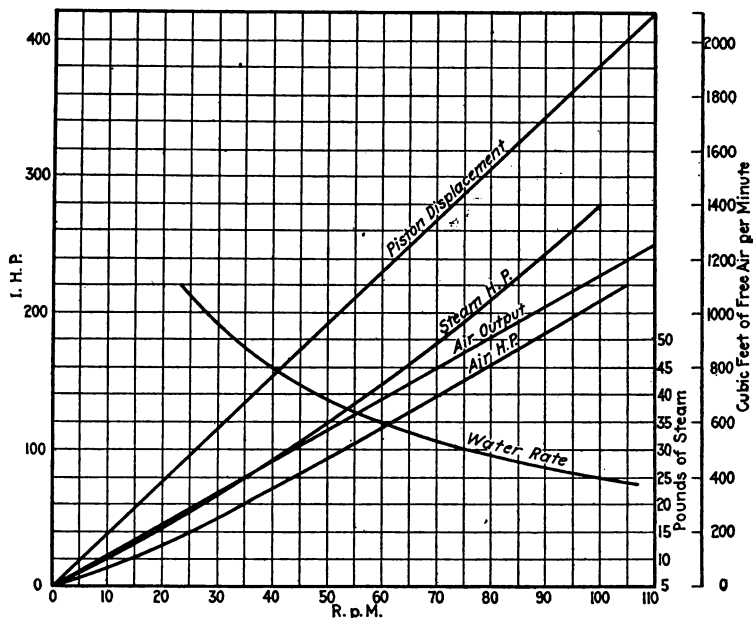

FIG. 117.—Test results of compressor plant No. 1.

Total coal burned, pounds.....	264,300
Total feed-water, cubic feet.....	37,459
Total feed-water, pounds.....	2,335,568
Average temperature of feed-water, degrees Fahrenheit.....	131
Average evaporation per pound coal consumed, pounds.....	8.72
Average revolutions per minute.....	63.1
Indicated horse-power of steam end, corresponding to 63.1 r.p.m.	161
Corresponding indicated horse-power of air end.....	123
Average steam pressure, pounds.....	115
Average vacuum, pounds.....	10.5
Average air pressure, pounds.....	96
Average temperature of outside air, degrees Fahrenheit.....	24
Average air piston displacement at 70° F., cubic feet.....	1,172
Average metered output corrected to 70° F., cubic feet.....	758

The average evaporation of 8.72 lb. of water from 131° F. to an average steam pressure of 115 lb., is equivalent to 9.83 lb. of water evaporated from and at 212° F. per pound coal consumed. At the average compressor speed of 63.1 revolutions per minute, the metered output was equivalent to 758 cu. ft. of free air per minute, the piston displacement being 1,172 cu. ft. per minute. Fig. 117 presents some of the principal data of the test run on this compressor.

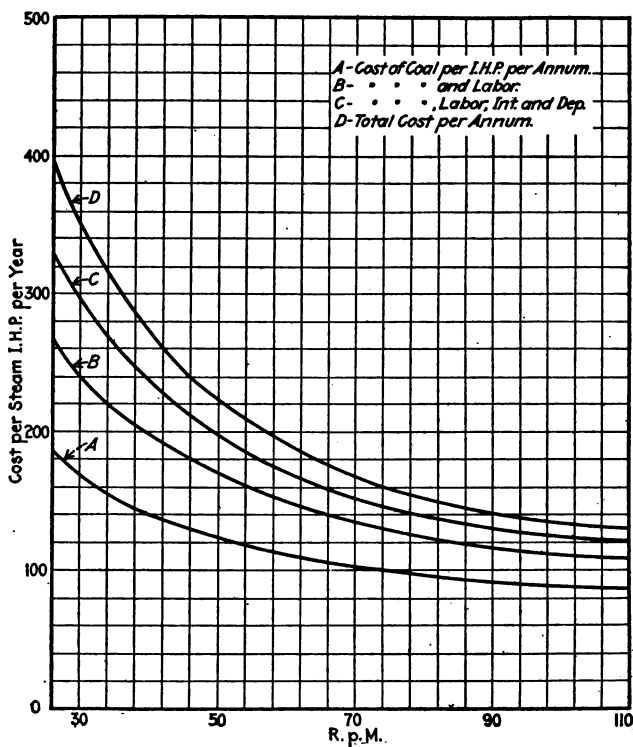

FIG. 118.—Test results of compressor plant No. 1.

To find the average operating results, the curves at 63 revolutions should be followed, at which the indicated horse-power of the steam cylinder was 160.8, and that of the air cylinder, 123, showing the mechanical efficiency to have been 76.5 per cent. The theoretical horse-power required to compress isothermally 1 cu. ft. of free air per minute to 96 lb. (the average pressure) is c. 129. The theoretical

useful work done by the compressor is, therefore, 758×0.129 or 97.8, and the net total efficiency of the compressor is $97.8 \div 161$ or 60.8 per cent.

The cost data were furnished by the owner and are based on one year's operation. In Fig. 118 these costs are plotted, showing how the cost per steam horse-power, per year is affected by the

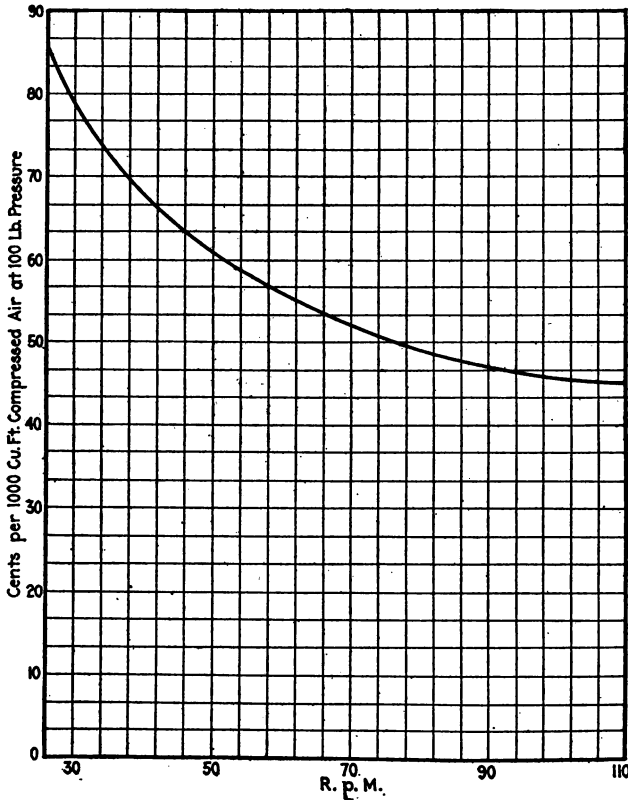

FIG. 119.—Test results of compressor plant No. 1.

average running speed of the compressor. The curve of Fig. 119 shows the operating costs in another way. These costs may be read in terms of 1,000 cu. ft. of free air compressed to 100 lb. or 1,000 cu. ft. of compressed air at 100 lb. gage pressure.

Test of Plant Number Two.—The plant consisted of three 150 h.p. return tubular boilers, supplying steam for a Corliss engine,

the air compressor, and steam heating. To determine the boiler horse-power, a meter was placed on the steam-pipe to the compressor during the test run, so that only the portion of steam actually used by the compressor was charged to the same. The compressor was duplex, with Meyer valve gear, simple steam cylinders 14×22 in.

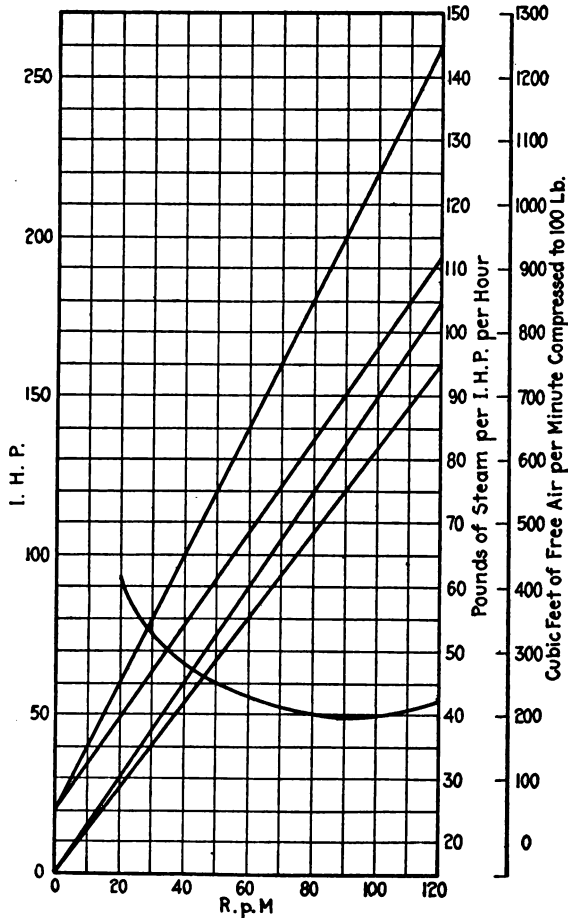

FIG. 120.—Test results of compressor plant No. 2.

and two-stage air end, 14 and 22×22-in. stroke, rated by the manufacturer at 1,050 cu. ft. of free air per minute at 105 revolutions. At this plant the test lasted over a month, with the following results:

Total coal consumed, pounds.....	459,250
Total feed-water, pounds.....	2,496,000
Average evaporation per pound coal consumed, pounds.....	5.46
Average revolutions per minute.....	36
Corresponding average indicated horse-power (from curve).....	53

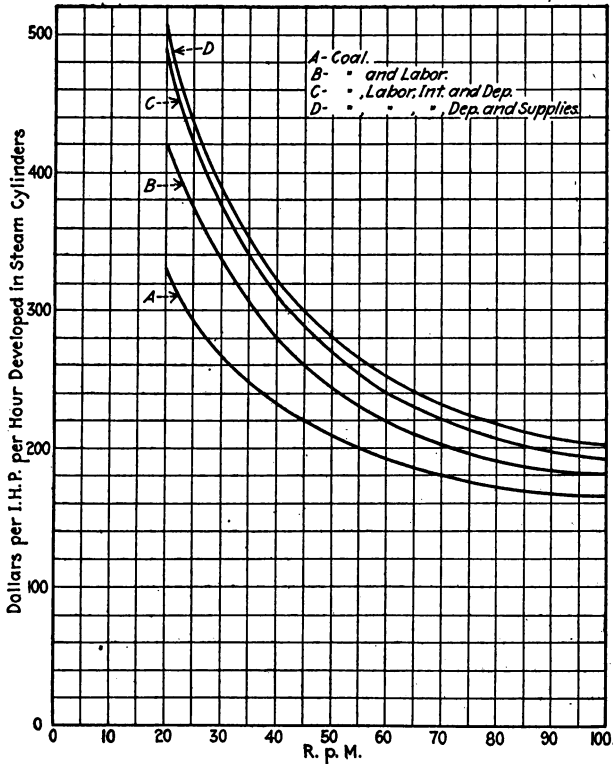

FIG. 121.—Test results of compressor plant No. 2.

Hourly readings of the revolution counter were taken, showing an average speed of 36.05 revolutions. At this speed the steam consumption was 51 lb. per indicated horse-power hour, as measured at the throttle, the air meter showing a delivery of 275 cu. ft. of free air per minute. The total efficiency was 67 per cent. Taking the ordinary method of computing the mechanical efficiency only at the same speed, there would be 48 air h.p., divided by 54 steam h.p., giving an efficiency of 89 per cent.

The coal consumption per indicated horse-power per year, as shown by the books of the company, amounted at the average speed to about 56 tons. Figs. 119, 120, 121, and 122 present details of the test on this plant, which was conducted similar to that on plant No. 1.

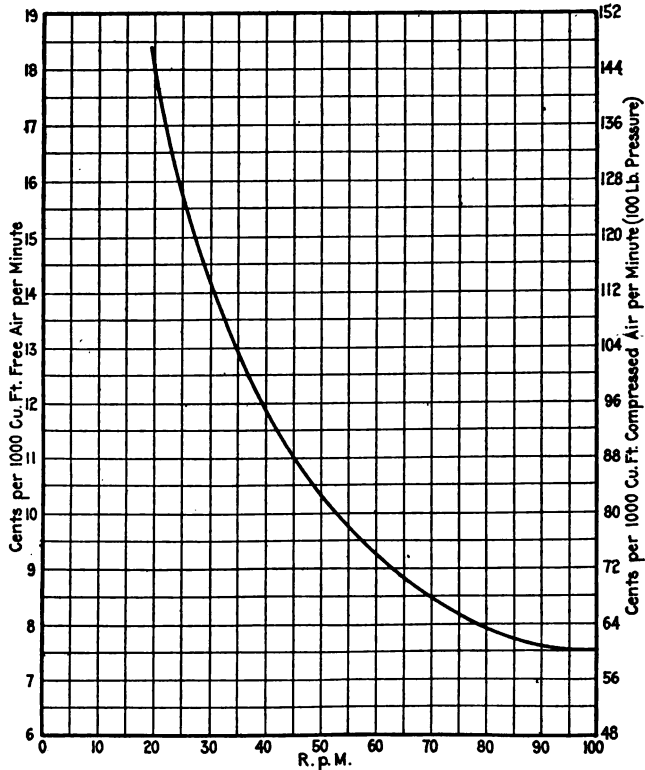

FIG. 122.—Test results of compressor plant No. 2.

Test of Plant Number Three.—This plant consisted of two 125 h.p. return tubular boilers, supplying steam for a non-condensing cross-compound air compressor of standard make; steam cylinders 18 and 35×24 in., air cylinders 14 and 28×24 in. A two weeks' run gave the following results:

Total coal burned, pounds.....	221,190
Total feed-water, cubic feet.....	34,273
Total feed-water, pounds.....	2,094,657
Average temperature feed-water, degrees Fahrenheit.....	154

Average evaporation per pound coal consumed, pounds.....	9.48
Average boiler horse-power.....	208
Average revolutions per minute.....	66
Average indicated horse-power of steam end, at 66 r.p.m. (from curve).....	210
Average indicated horse-power of air end (from curve).....	128.5
Average steam pressure.....	97
Average air pressure.....	97
Average outside temperature, degrees Fahrenheit.....	23
Average air piston displacement at normal speed, cubic feet, at 70° F.....	1,372
Metered output in cubic feet corrected to 70° F.....	734

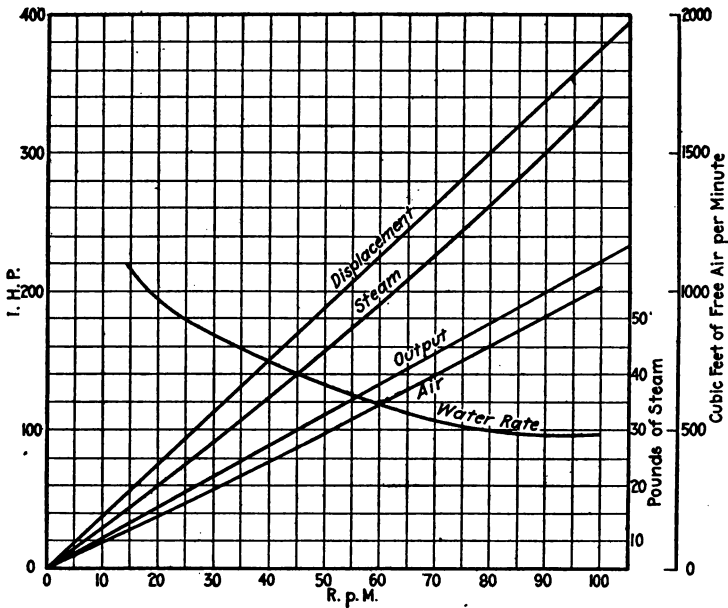

FIG. 123.—Test results of compressor plant No. 3.

The average evaporation of 9.48 lb. of water per pound of coal, from 154° F. to an average steam pressure of 97 lb., is equivalent to 10.4 lb. of water evaporated from and at 212° F. At the average speed of 66 revolutions, the displacement was 1,240 cu. ft. of free air per minute, while the metered output was 734 cu. ft., showing a net volumetric efficiency of 59 per cent.

To determine the conditions in average operation, the curve at 66 revolutions should be followed (Fig. 123), at which the indicated horse-power of the steam cylinders was 210, and that of the air cylinders, 128. This shows the efficiency to be 61 per cent., the friction loss being 81.5 h.p. or 39 per cent. of that delivered by steam

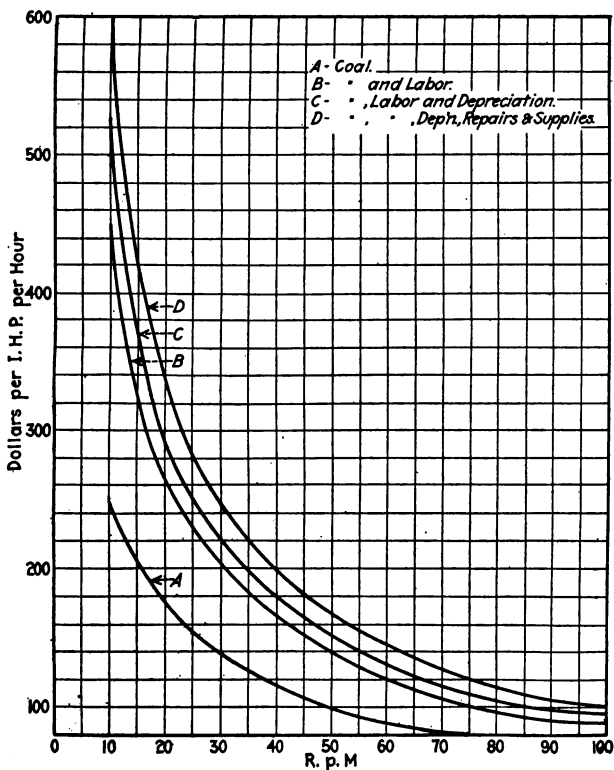

FIG. 124.—Test results of compressor plant No. 3.

end. This extremely high friction loss was due to the fact that the compressor shaft was out of line, and the plant could not be shut down long enough to rectify it. The details and results of this test are interesting in exhibiting the inefficiency that may be caused by a purely mechanical defect. (Figs. 123, 124, and 125).

Test Number Four.—The results of a test on another plant are given in Fig. 126, the details of the boiler test and of the costs being omitted. In this case the compressor was of the tandem compound non-condensing type, with Corliss valve gear for the

steam cylinders. The test shows that, at a low speed, the steam consumption increases more rapidly than with the Meyer type of valve.

Summary.—The results of these tests are enlightening, in showing the actual amount of the losses occurring in the compression of air, particularly when the compressor is operating under the unfavorable conditions of varying air consumption necessarily obtaining in

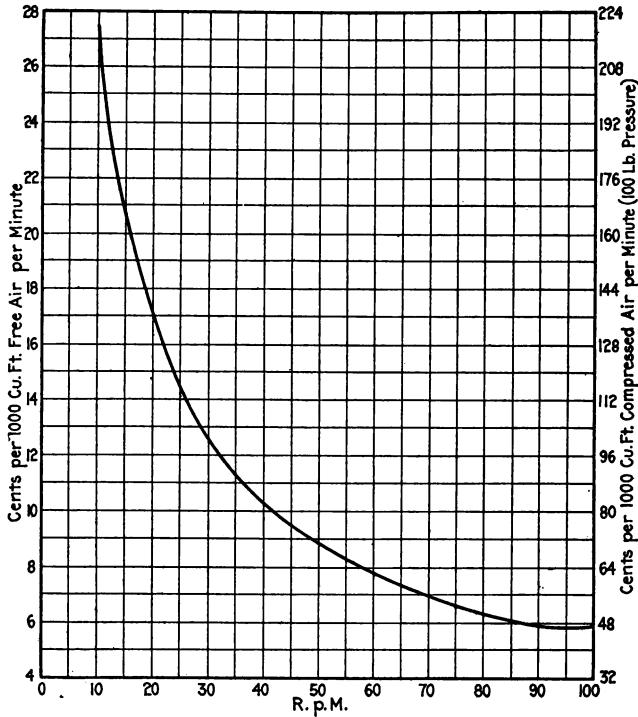

FIG. 125.—Test results of compressor plant No. 3.

mining and other work in which machine drills play an important part. These losses are always recognized as existing by compressor builders and by intelligent users, and it is clearly desirable that properly conducted tests should be made more frequently.

Again, compressor plants generally develop less power than their full rated capacity. It should be remembered that an air compressor is essentially a variable speed machine, its speed being regulated by some form of throttling governor, connected with the air-pressure regulator. The machine is therefore called on to run only as fast

as the demand for air may require. It may be suggested that it would be well for compressor builders to give in their catalogues the actual horse-power rating at different speeds, with a table of

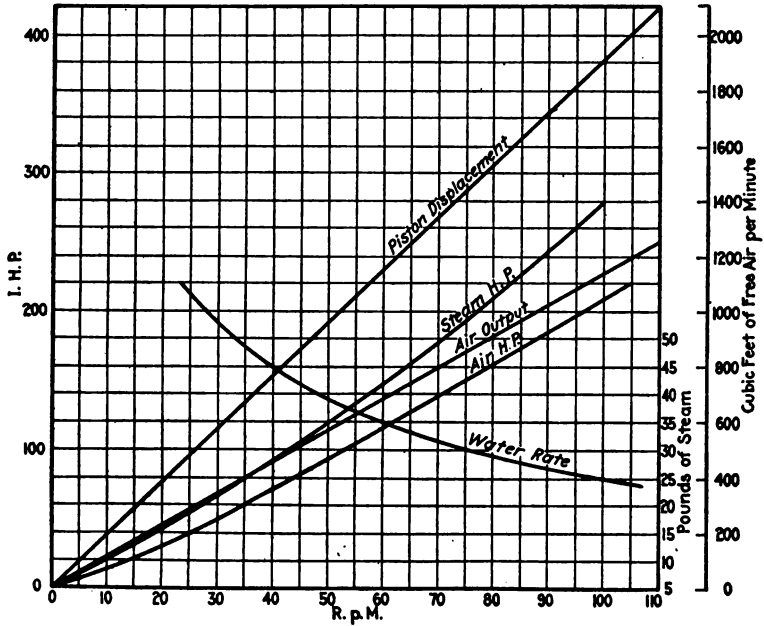

FIG. 126.—Test results of compressor plant No. 4.

efficiencies at different loads and speeds, just as is done by some of the manufacturers of electrical machinery. Catalogues might also include some definite data respecting the cost per horse-power delivered by the air end of the compressor at different working speeds.

CHAPTER XIV

RECEIVERS. MEASUREMENT AND TRANSMISSION OF COMPRESSED AIR

RECEIVERS

The purpose of installing a receiver is four-fold: First, to equalize the pulsations in the air coming from the compressor; second, to collect the water and grease held in suspension by the compressed air as it leaves the compressor; third, to reduce the friction of air in the pipe system; and fourth, to cool the air as thoroughly as possible before entering the transmission system.

It does not act primarily as a reservoir of power, for in order to accomplish this its size would become impractical. However, in

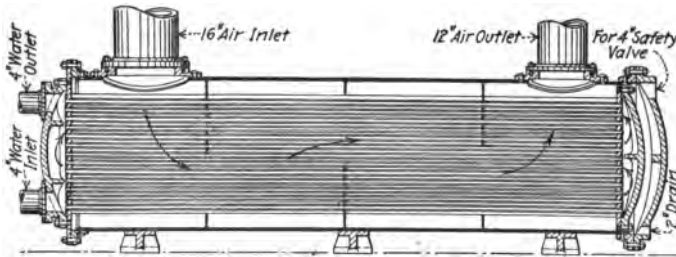

FIG. 127.—Receiver aftercooler.

compensating for the air pulsations it maintains constant pressure in the pipe line and in that way reduces friction.

In order to facilitate the removal of water from the compressed air, it is frequently equipped with a coil of pipes (Fig. 127) filled with cooling water, in this way serving as an “after-cooler,” as it is called. When so equipped the difficulty with water in the transmission line and frost at the exhaust pipe of a compressed-air motor is reduced.

When the pipe line is very long, receivers are placed at both ends of the pipe; this increases the effectiveness of the receiver and reduces materially the pipe friction.

As manufactured, these receivers are usually supplied with a pressure-gage, safety-valve, blow-off cock and frequently a man-hole. They are made either horizontal or vertical and of cubical contents varying usually from 30 to 400 cu. ft. For exceptional cases as for compressed air-pressure water systems, they are frequently made much larger.

THE MEASUREMENT OF AIR AND GASES

“The measurement of compressed air and gas in the commercial distribution and sale of these commodities and in testing compressors has attracted a great deal of attention in recent times and excellent articles¹ are to be found in the technical press. The material here given has been gathered from these sources and includes some interesting results of tests made in the Steam and Gas Engineering Laboratory of the University of Wisconsin.

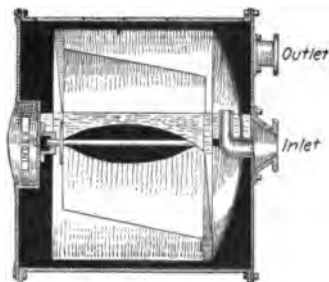

FIG. 128.—Wet displacement meter.

“Standards of Measurement.— In making measurements it is usually necessary to ascertain the number of ‘standard cubic feet’ passing in a given time. The contents of a standard cubic foot are determined by the assumed standards of temperature and pressure used in defining the unit of measurement. Scientific data on gases are usually referred to the freezing temperature of water and to the mean barometric pressure. Common commercial standards of temperature and pressure in gas measurement are 60° F. and 30 in.

of mercury, respectively.

“A quite general classification of meters includes two main types: volumetric meters and velocity meters.

“**Volumetric Meters.**—Volumetric meters include what are known as ‘dry meters,’ operating on the general principle of a bellows, and ‘wet meters.’ The latter are built in large sizes for use at gas works

¹ The Measurement of Gases, Prof. Carl C. Thomas, *Jour. Franklin Inst.*, Nov., 1911. Measurement of Nat. Gas, Thos. R. Weymouth, *Jour. A. S. M. E.*, Nov., 1912. Flow of Gas through Lines of Pipe, Forrest M. Towl, Lecture Columbia Univ., 1911.

in measuring the gas, as made, before being passed for storage to the holders (Fig. 128). These meters are known as station meters, their construction is, in general, that of a drum revolving within a cylinder or tank which is more than half filled with water. The revolving drum consists of a shaft carrying three or four partitions arranged in a spiral form. These partitions emerge in turn from the water as the shaft revolves, and each forms with the water a water-sealed compartment, which alternately receives and delivers gas. The drum receives its motion from the pressure of the gas itself and the number of revolutions of the shaft when properly calibrated give an index of the quantity of gas passing through the meter.

In testing air compressors, volumetric methods of measuring the air compressed are sometimes used by installing three tanks. The compressor is arranged to discharge constantly into one of these at a constant pressure. This tank in turn discharges alternately into either of the other two. It fills one tank while the other is being discharged to the atmosphere and when the pressure approaches that of the compressor the discharge is turned into the empty tank. By noting the temperature and pressure and having the volume of the two tanks it is possible to calculate the volume of air which each has received from the compressor.

“Velocity Meters.—Volumetric methods of measurement, however, are not always feasible nor very satisfactory, and other methods of measurement depending on the velocity of flow of the air or gas have been developed and made use of in commercial work. These methods may be separated into three types: the orifice or Pitot-tube type, which depends for its operation upon fundamental principles of hydraulics; the Venturi meter, which depends upon thermo-dynamic principles involved in the adiabatic expansion of the gas or air as it flows through the reduced cross-sectional area of the Venturi tube; and the heat meter, of which the Thomas electric meter, manufactured by the Cutler-Hammer Co., Milwaukee, Wis., is the best example, in which the temperature of the gas or air is increased through a known range by a measurable amount of heat. From a knowledge of the specific heat of the gas and air, the weight of gas or air flowing through the meter is automatically determined and recorded.

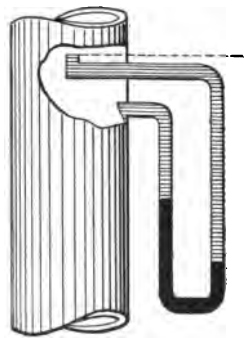

FIG. 129.—Simple form of Pitot tube.

“Pitot Tube.—The Pitot tube (Fig. 129) affords a means of

measuring the velocity of air or gas through a pipe at any given point in the pipe section. In its simplest form it consists of two small tubes inserted in the pipe line—one having an opening pointed up-stream and communicating to one end of a U-tube the pressure due to velocity head in addition to the static pressure in the pipe; the other having an opening at right angles to the direction of flow and communicating to the opposite end of the U-tube the static pressure only. The difference between these two pressures is the pressure due to velocity alone, and from this, velocity of the gas or air in the pipe can be computed by means of the formula $v^2 = 2gh$ where h is the static head necessary to give to the air or gas a velocity of v ft. per second. From a knowledge of the cross-sectional area

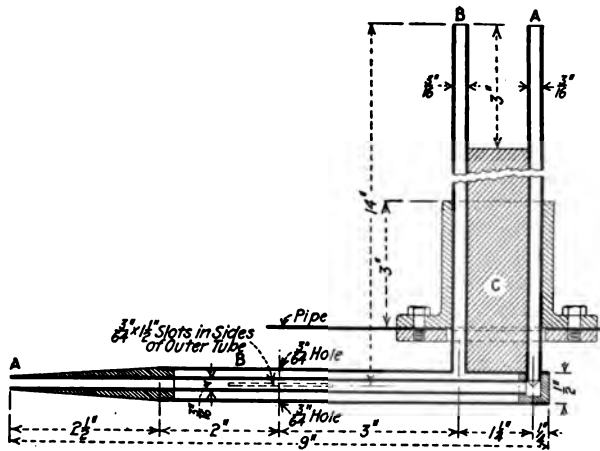

FIG. 130.—Modern form of Pitot tube.

of the pipe and the density of gas at observed pressure and temperature, the quantity passing per unit of time can be computed. Fig. 130 shows a modern type of Pitot tube.

“The velocity of gas flowing through a pipe is not the same at all points in the section. It falls off gradually from the center outward and very rapidly near the inner skin of the pipe. In order to obtain accurate results with Pitot tubes, without exploring the pipe at several different depths, it is necessary to ‘standardize’ the tube and pipe together and find the depth at which the tube will indicate the mean velocity; that is, a Pitot tube will not necessarily give consistent readings if placed in a given position in pipes of different sizes, different conditions of surface, etc. The tube must be located with special reference to the size, shape, and condition of pipe with which it is used. Great care must be taken that the openings

through which the pressures are communicated to the U-tube are properly placed with respect to the direction of flow, and they must be kept free from deposits.

“The general formula for the Pitot tube and the orifice is derived from the law of falling bodies. Let

- T = absolute temperature of flowing gas, degrees Fahrenheit.
- P = absolute pressure of flowing gas, pounds per square inch.
- w = weight per cubic foot of flowing gas, at P and T .
- G = specific gravity of flowing gas, (air 1.0).
- v = actual velocity of flowing gas, feet per second.
- h_f = height in feet of homogeneous column of gas at P and T producing v .
- h = corresponding height of water column in inches.
- w_w = weight per cubic foot of water, 62.37 lb. at 60° F.
- P_s = absolute storage pressure base, pounds per square inch.
- T_s = absolute storage temperature base, degrees Fahrenheit.
- w_a = weight per cubic feet air at 32° F. and 14.7 lb. = 0.08073 lb.
- d = actual inside diameter of pipe or orifice in inches.
- E = efficiency of Pitot tube or orifice.
- Q = flow in cubic feet per hour at P_s and T_s .

Then

$$v = \sqrt{2gh_f} = \sqrt{2g \frac{h w_w}{12w}}$$

$$w = w_a G \frac{P 492}{14.7 T}$$

$$v = \sqrt{2g \frac{h w_w 14.7 T}{12 w_a 492 P G}}$$

$$Q = 3,600 \frac{\pi d^2}{4 \times 144} v \frac{P T_s}{P_s T} E$$

$$Q = 218.44 E d^2 \frac{T_s}{P_s} \sqrt{\frac{hP}{TG}}$$

“Prof. S. W. Robinson who was probably the first to use the Pitot tube in connection with the flow of natural gas has developed the following formula which has been used by natural gas men for a number of years:

$$Q = 1,462,250 d^2 \left\{ \left(\frac{P_1}{P_0} \right)^{0.29} - 1 \right\}^{\frac{1}{2}}$$

This was derived from the formula for adiabatic flow

$$v^2 = \frac{2gn \times 144 P_0}{(n-1)w} \left\{ \left(\frac{P_1}{P_0} \right)^{\frac{n-1}{n}} - 1 \right\}, \text{ in which}$$

v = velocity of flowing gas, feet per second.

P_0 = absolute pressure of the atmosphere, pounds per square inch.

n = ratio of the specific heats.

w = weight per cubic foot of gas at pressure P_0 .

G = specific gravity of gas, air 1.

P_1 = absolute pressure shown by Pitot tube, pounds per square inch.

d = internal diameter of well mouth, inches.

Q = open-flow capacity of well, cubic feet per 24 hours.

"Prof. Robinson has computed tables from the above formula which have been used for years. The computations are based on the following:

$$n = 1.408$$

$$2g = 64.3$$

$$P_0 = 14.6$$

$$G = 0.6$$

$$w = 0.0807 \frac{T_0}{T} G.$$

$$T = T_0 = T_s = 492^\circ \text{ F.}$$

T_0 = absolute temperature of melting ice.

T = absolute temperature of flowing gas.

T_s = absolute temperature of storage.

"Thos. R. Weymouth in his article in the *Journ. A. S. M. E.* points out that for natural gas the ratio of the specific heats is more nearly equal to 1.266 and by using

$$T = 500^\circ \text{ F.}$$

$$T_s = 520^\circ \text{ F.}$$

$$P_0 = 14.4$$

$$P_s = \text{storage pressure } 14.65$$

the formula becomes:

$$Q = 1,758,560 d^2 \left\{ \left(\frac{P_1}{14.4} \right)^{0.21} - 1 \right\}^{\frac{1}{2}}$$

"In order to obtain a mean value of h for the use in Pitot tube measurements Prof. G. J. Davis of the University of Wisconsin devised the following method which is illustrated in Figs. 131 and 132 showing results of an actual test of a Pitot tube placed tandem with a Venturi meter and a Thomas electric meter.

"The horizontal represents distances from the center of the pipe at which readings of h were observed. On the vertical a suitable scale of values of \sqrt{h} is laid off. Readings of \sqrt{h} are then plotted and joined by radial lines to the point representing the center of the pipe. The intersections of the slanting lines with the perpendiculars

representing the positions at which the corresponding values of \sqrt{h} were read are points through which a smooth curve can be drawn. The area under the curve may now be determined and from this the altitude of a triangle having the same area and base as the irregular figure will give the mean h to be used in computing the mean velocity.

“The mean velocity V is determined from the formula $V^2 = 2gh$ after reducing the h determined to equivalent feet of air. The pounds per hour will then equal 3,600 AVG where A is the area of the pipe in square feet.

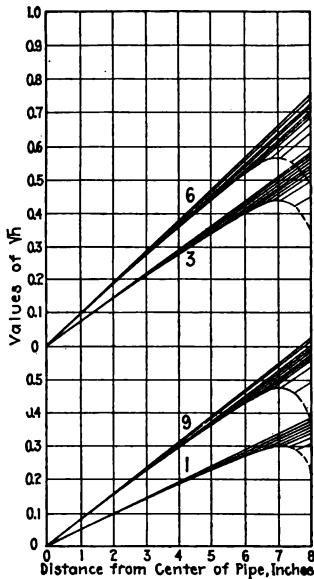

FIG. 131.—Graphical method of determining mean head.

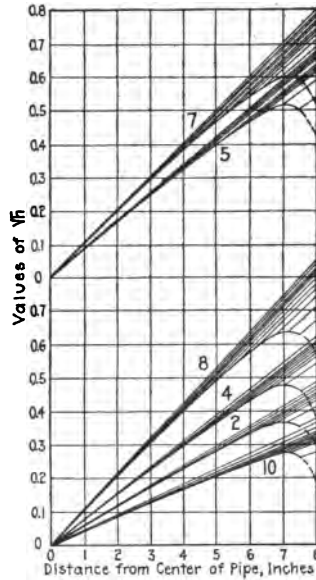

FIG. 132.—Graphical method of determining mean head.

V is the velocity in feet per second.

G is the weight of a cubic foot of air as it passed through the pipe.

“In measuring air by means of a Pitot tube it is necessary to take into account the humidity of the atmosphere and make corrections as indicated in the discussion on Humidity given in Appendix C.

“In measuring large quantities of air in testing air compressors it is quite a common practice to have the air escape through a suitable orifice to the atmosphere. An apparatus of this kind is shown in Fig. 22 and one for large installations in Fig. 133.

“The formula usually used for measuring air under these conditions is

$W = 0.53A \frac{P_1}{\sqrt{T_1}}$ where P_1 is greater than twice atmospheric pressure.

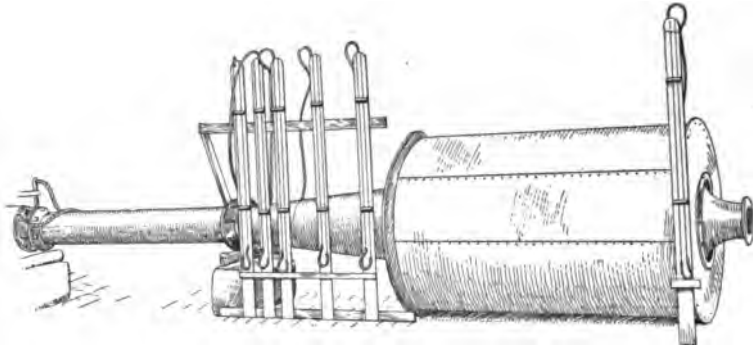

FIG. 133.—Apparatus for measuring large quantities of air.

When P_1 is less than twice atmospheric pressure the formula usually used is

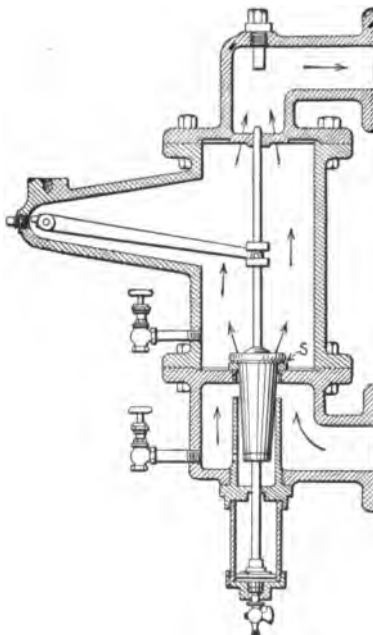

FIG. 134.—St. John meter.

$$W = 1.060A \sqrt{\frac{P_a(P_1 - P_a)}{T_1}}$$

“This last formula, however, is not entirely reliable (see ‘Air Flowing into Atmosphere through Circular Orifices’ by R. J. Durley, Trans. A. S. M. E., Vol. 27).

In the above formulæ

W = weight of air escaping in pounds per second.

P_a = pressure of atmosphere in pounds per square inch.

P_1 = pressure before the nozzle in pounds per square inch absolute.

T_1 = absolute temperature of air entering the nozzle.

A = area of nozzle in square feet.

“In using a nozzle or orifice it is also necessary to consider the humidity of the atmosphere in measuring air.

“**St. Johns Meter.**—A number of meters have been made making use of an orifice for measuring the flow of air. Such meters are usu-

ally calibrated by means of a gasometer. The St. Johns meter, Fig. 134, is in effect a variable orifice meter. The position of the plug *S* determines the size of the orifice through which the air passes and a graphical record is kept of the position of this plug on a drum moved by clock work and by planimetering this chart the average position can be determined and the consumption be calculated.

“**Venturi Meter.**—The Venturi meter, Fig. 135, consists of a throat or gradually contracted portion of the passage, which causes a de-

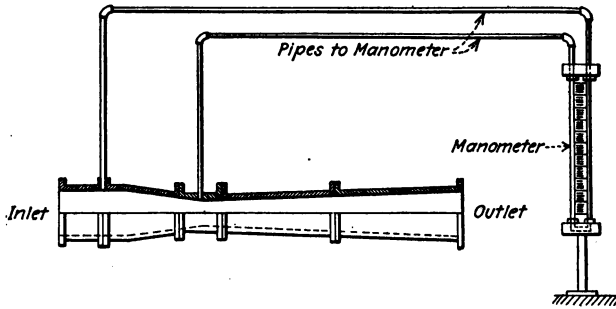

FIG. 135.—Venturi tube.

crease in pressure and increase in velocity of the gas flowing through it.

“Let A_1 = area of the up-stream section in square feet.

A_2 = area of throat in square feet.

P_1 = pressure at up-stream side, pounds per square inch.

P_2 = pressure at throat, pounds per square inch.

G_1 = weight of gas at up-stream section, pounds per second.

n = ratio of specific heats, constant pressure to constant volume.

V_2 = velocity of gas at throat, feet per second.

“By equating the loss in potential energy to the increase in kinetic energy it is found that

$$V_2 = \left(\frac{P_1}{G_1}\right)^{\frac{1}{2}} \left(\frac{2gn}{n-1}\right)^{\frac{1}{2}} \left\{ \frac{1 - \left(\frac{P_2}{P_1}\right)^{\frac{n-1}{n}}}{1 - \left(\frac{A_2}{A_1}\right)^2 \left(\frac{P_2}{P_1}\right)^{\frac{2}{n}}} \right\}^{\frac{1}{2}}$$

“The quantity flowing $Q = A_2 V_2 G_1 \left(\frac{P_2}{P_1}\right)^{\frac{1}{n}}$ in cubic feet per second.

“It is frequently necessary to take small readings of pressures with both the Pitot tube and Venturi meter, and in order to do this

accurately the water columns should be read with a micrometer gage or differential (inclined) water column.

"A similar formula for the flow expressed in cubic feet per hour would be

$$Q_1 = 210,840 A_2 \frac{T_s}{P_s} \sqrt{\frac{n}{(n-1)G}} \frac{P_1}{\sqrt{T_1}} \left(\frac{P_2}{P_1}\right)^{\frac{1}{n}} \sqrt{\frac{1 - \left(\frac{P_2}{P_1}\right)^{\frac{n-1}{n}}}{1 - \left(\frac{A_2}{A_1}\right)^2 \left(\frac{P_2}{P_1}\right)^{\frac{2}{n}}}}$$

"Terms in this formula not appearing in the other are

Q_1 = flow in cubic feet per hour.

T_1 = absolute temperature of gas at entrance.

T_s = absolute temperature of storage base pounds per square inch.

P_s = absolute pressure of storage base pounds, per square inch.

G = specific gravity of gas, air = 1.

"**Thomas Meter.**—The Thomas electric meter is based upon the principle of heating the air or gas through a known range of temper-

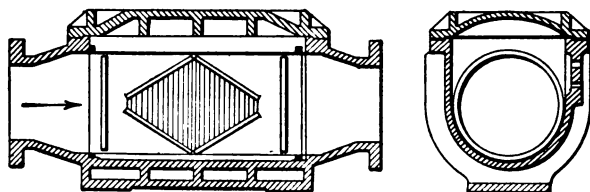

FIG. 136.—Sectional view of Thomas electric meter.

ature. This measured energy is proportional to the weight of the gas flowing. Electric energy is used as a source of heat because it can be so conveniently and accurately applied and measured. Electrical resistance thermometers are used to regulate the temperature range through which the gas is heated, because with thermometers of such type very small differences of temperature can be accurately and easily determined.

"A sectional view of a 10-in. meter and casing is shown in Fig. 136. Fig. 137 shows the meter diagrammatically. The electric heater is placed within the casing between two electric resistance thermometers, T_1 and T_2 . The heater consists of spiral turns of bare nichrome resistance wire wound around a conical frame and supported by insulators, so that heat is dissipated evenly over the section of the pipe. A rheostat is placed in the heater circuit for regulating the direct current supplied. This energy is measured by an ammeter and voltmeter.

"The thermometers consist of resistance wire wound on wooden

spindles and evenly distributed over the section of the casing. The wire is of such material that its resistance increases with the temperature according to known laws. The two thermometers form two arms of a Wheatstone bridge, the other two arms being fixed coils of wire that have a zero temperature coefficient. A galvanometer is connected across the Wheatstone bridge, and a small rheostat is placed in series with one thermometer for balancing the bridge when no heat is passing through the heater. A small resistance R_i is arranged so that it can be placed in or out of series with the entrance thermometer. This resistance is equal in value to the increase in

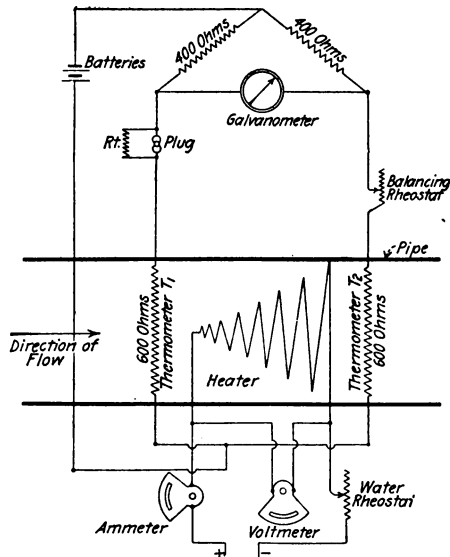

FIG. 137.—Diagrammatic sketch of Thomas electric meter.

resistance of the exit thermometer for a rise in temperature of practically 2° F. The meter in the laboratory of the University of Wisconsin is for 2.0152° F.

“The operation of the meter is as follows: With gas flowing through the meter but with no energy in the heater, and with R_i out of circuit, the two thermometers are brought to the same balance by means of the balancing rheostat and the galvanometer. Then the resistance R_i is put in circuit and sufficient electrical energy is supplied to the heater to bring the galvanometer to balance again, by bringing the exit gas to a temperature 2.0152° , with the meter mentioned, higher than that of the entering gas. The measuring instruments in the heater circuit then indicate the energy required

to raise the temperature of the air or gas through a known range. The quantity of gas flowing can be found by the equation

$$W = \frac{3.412E}{ts}$$

where W is the number of pounds of gas or air per hour, E the amount of energy supplied in watts per hour, t the rise of temperature in degrees Fahrenheit, and s the specific heat at constant pressure of the gas or air.

“With the laboratory meter the air flowing through the meter per minute is given by the formula $0.028218 E_s$.

“In applying this meter to gases it is necessary to ascertain the composition of the gases in order to obtain the mean specific heat for use with the meter.

“The meter in commercial form is equipped with automatic devices to regulate the flow of current through the heater so as to maintain a constant difference of temperature between the resistance thermometers of 2° . The electrical instruments for measuring the consumption of current in the heater are then calibrated to read either weight or quantity of gas flowing and this reading is recorded graphically.

“**Meter Comparisons.**—At the University of Wisconsin tests were run by placing a Venturi meter, Pitot tube and Thomas meter

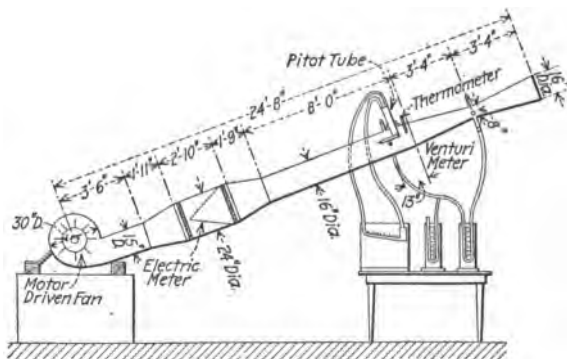

FIG. 138.—Sketch of meters placed tandem for testing.

in tandem, as shown by Fig. 138. The results of these tests are shown as Fig. 139. A remarkable similar set of readings were secured.

“In April, 1911, a Thomas meter was tested on a natural-gas line by comparison with Pitot-tube measurements giving practically identical results. This meter had a maximum capacity of 750,000 cu. ft. of free gas per hour and an accurate minimum capacity of 12,500 cu.

ft. It gave a continuous graphical record and integrated values of the gas directly in standard cubic feet at 15.025 lb. absolute pressure and 60° F., although the pressure of the gas varies from 50 to 200 lb. gage and the temperature varies with weather conditions. The specific heat was calculated from an average analysis of the gas for the standard conditions given above. This particular meter was placed in a 10-in. line and located about a mile and a half from a very

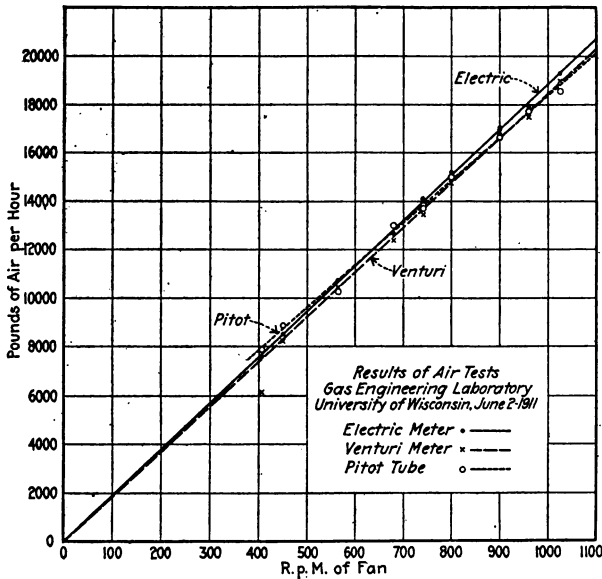

FIG. 139.—Result of test.

complete Pitot-tube meter station. A 22-hour comparative test showed a difference of 0.2 per cent. between the two meters and a similar comparative test from April 17 to June 3, 1911, showed the same difference.”

PIPE LINES¹

“The transporting of gas or air requires a line which shall be “air tight.” It is much more difficult to make a line to hold gas or air under pressure than it is to hold a liquid. Trouble has been experienced in almost all lines built for high pressure on account of the leaking of the gas at the couplings. The first high-pressure lines were laid with bell and spigot joints, caulked with lead. The lines

¹ Forrest M. Towl, Lecture Columbia University, 1911.

might be tight when they were first laid but they expanded and contracting soon caused them to leak.

"The next lines used were of wrought iron or steel with screw joints. While these held much better than the bell and pipe, there was still enough leakage to make it desirable to have a perfect joint. The leakage on some of the earlier size lines was such that by putting a rubber bag over the ends could often be collected at the rate of from 20 to 50 cu. ft. or enough to run a good-sized torch. This was true of lines 8 or 10 in. in diameter. When the lines became larger, the leakage increased so much that it was practically impossible to use these size lines and get a large percentage of the product at the market.

"As the demand for natural gas increased, it became necessary to use larger lines, and a rubber packed stuffing-box was developed. The first successful joint of this kind in the market was the Dresser coupler, and it is due largely to this and other couplings that the natural-gas industry has become so great.

"**Dresser Coupler.**—The Dresser coupler consists of a sleeve into which the ends of the pipe are placed. There is a projection at the center of the sleeve so that the ends of the pipe will be each inserted into the sleeve the same distance. This sleeve acts as a follower to compress rubber in an annular space into the end rings which are drawn together by bolts. The rubber is surrounded on one side by the pipe, on another by the body of the coupling, and on the remaining side by the end rings so that there is very little of the surface of the rubber exposed either to the gas on the inside or the air on the outside of the line. It is found that these joints will last for years. (Fig. 140 shows a cross-section of the Dresser coupler.)

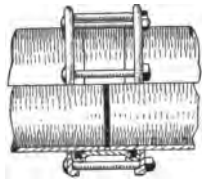

FIG. 140.—Dresser pipe coupler.

"**Hammon Coupler.**—The Hammon coupler is a modification of the Dresser, one of the principal features of which is that the projection at the center of the sleeve is made by lugs welded onto the sleeve. When it becomes necessary to take apart one of these couplers, the lugs can be broken off and the coupler slipped back so as to allow the pipe to be easily removed. (Fig. 141 shows the Hammon coupler.)

"Lines of pipe can be built in almost any kind of country, but it is necessary in some places to arrange to keep the lines from acting as a Bourbon tube and expanding in one direction until the ends of the pipe may be pulled out of the coupling. To avoid this trouble it is customary in such places as river crossings to use screw pipe, and to place over the collar a clamp which is constructed to make a rubber joint between the ends of the collar and the pipe.

“For power-transmission lines or for temporary gas lines, where the distances are short or the service temporary, it is not considered necessary to bury the pipe, it will be found that the screw-joint pipe is satisfactory, but for other natural-gas or air service, the rubber coupling has many things to recommend it, and when the capacity requires large pipe, it is almost absolutely necessary to use this type of coupling. These couplings have been used for manufactured gas, but it is found that the condensation from the gas collects in the coupling and soon causes a leak in the rubber joint. Work is now in progress to perfect a material which will not be acted upon by the condensation in the gas and which will make a gas-tight joint.

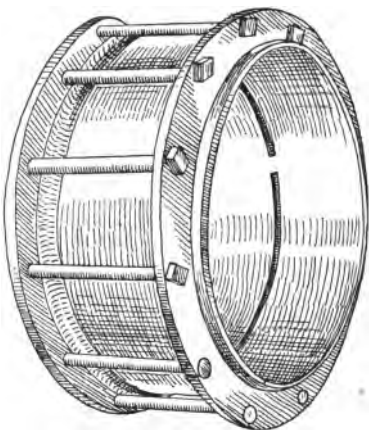

FIG. 141.—Hammon pipe coupler.

In using screwed joints for air it is necessary that the lead, litharge, or other material used at the joint should be applied on the ends of the pipe and not in the couplings, so that the surplus is brought outside instead of within the pipe where it may cause a more or less serious obstruction.”

Pipe-line Formulæ.—A very simple formula is often used for calculating pipe lines for compressed air.

$$D = c \sqrt{\frac{d^5(p_1 - p_2)}{w_1 l}}, \text{ or } D = \frac{c \sqrt{d^5}}{\sqrt{l}} \times \sqrt{\frac{p_1 - p_2}{w_1}}$$

in which

D = the volume of compressed air in cubic feet per minute discharged at the final pressure.

c = a coefficient varying with the diameter of the pipe, as determined by experiment,

d = diameter of pipe in inches,¹

l = length of pipe in feet,

p_1 = initial gage pressure in pounds per square inch,

p_2 = final gage pressure in pounds per square inch,

¹ The actual diameters of wrought-iron pipe are not the same as the nominal diameters for all sizes. This difference is small, however, except in the 1 1/4 in. and 1 1/2 in. sizes, the actual diameters of which are 1.38 in. and 1.61 in. respectively.

w_1 = the density of the air, or its weight in pounds per cubic foot at the initial pressure p_1 .

The second form of the formula, as given above, will be found convenient for most calculations, as the factors can be considered in groups.

In Tables XIII and XIV are given the values of c , d^5 , and $c\sqrt{d^5}$. The values of c show some apparent discrepancy for sizes of pipe larger than 9 in. but there would be no very material differences in the results.

TABLE XIII

Diameter of pipe, inches	Values of c	Fifth powers of d	Values of $c\sqrt{d^5}$
1	45.3	1	45.3
2	52.6	32	297
3	56.5	243	876
4	58.0	1,024	1,856
5	59.0	3,125	3,298
6	59.8	7,776	5,273
7	60.3	16,807	7,817
8	60.7	32,768	10,988
9	61.0	59,049	14,812
10	61.2	100,000	19,480
11	61.8	161,051	24,800
12	62.0	248,832	30,926

TABLE XIV.—VALUES OF w_1 FOR INITIAL PRESSURES UP 100 LBS. PER SQUARE INCH:

Gage pressure, pounds	w_1	$\sqrt{w_1}$	Gage pressure, pounds	w_1	$\sqrt{w_1}$
0	0.0761	0.276	55	0.3607	0.600
5	0.1020	0.319	60	0.3866	0.622
10	0.1278	0.358	65	0.4125	0.642
15	0.1537	0.392	70	0.4383	0.662
20	0.1796	0.424	75	0.4642	0.681
25	0.2055	0.453	80	0.4901	0.700
30	0.2313	0.481	85	0.5160	0.718
35	0.2572	0.507	90	0.5418	0.736
40	0.2831	0.532	95	0.5677	0.753
45	0.3090	0.556	100	0.5936	0.770
50	0.3348	0.578			

Mr. Frank Richards gives the following formula for determining the loss of pressure in pipes:

$$H = \frac{V^2 L}{10,000 D^5 a} \text{ from which}$$

$$V = \sqrt{\frac{10,000 D^5 a}{L}}$$

In these equations

D = diameter of pipe in inches.

L = length of pipe in feet.

V = volume of compressed air delivered in cubic feet per min.

H = head of difference of pressure required to overcome friction and maintain the flow.

a = constant depending on the diameter of the pipe.

TABLE XV.—VALUES OF a , D^5 AND $D^5 a$ FOR WROUGHT-IRON PIPE.

Nominal pipe diameter	a	D^5	$D^5 a$
1 in.	0.35	1	0.35
1½ in.	0.5	3.05	1.525
1½ in.	0.662	7.59	5.03
2 in.	0.565	32.	18.08
2½ in.	0.65	97.65	63.47
3 in.	0.73	243.	117.4
3½ in.	0.787	525.	413.2
4 in.	0.84	1024.	860.2
5 in.	0.934	3125.	2918.75
6 in.	1.000	7776.	7776.
8 in.	1.125	32768.	36864.
10 in.	1.2	100000.	120000.
12 in.	1.26	248832.	313528.
16 in.	1.34	1048575.	1405091.
20 in.	1.4	3200000.	4480000.
24 in.	1.45	7962624.	11545805.

For example, suppose it is desired to determine the loss in pressure in transmitting 300 cu. ft. of compressed air per min. through a 6-in. pipe one mile in length.

$L = 5280$, $D^5 a$ for a 6-in. pipe = 7776

$H = \frac{300^2 \times 5280}{10000 \times 7776} = 6.11$. That is, the pressure drop will be

6.11 lb.

As another example, suppose it is desired to ascertain the proper size of wrought-iron pipe for transmitting compressed air from a compressor of 1500 cu. ft. free air capacity per min. at 80 lb. gauge a distance of 2000 ft., with an allowable loss of pressure of 5 lb.

The pressure at delivery will be 75 lb. gauge or practically 6 atmospheres. The volume of compressed air delivered per minute will be:

$$1500 \div 6 = 250 \text{ cu. ft. per min.} = V$$

As $H = 5$ the formula

$D^5a = \frac{V^2L}{10000H}$ may be used with proper substitutions, from which

$$D^5a = \frac{250^2 \times 2000}{10000 \times 5} = 2500.$$

From Table XV it is seen that D^5a for a 5-in. pipe is 2918.75 and for a 6-in. pipe 7776. This would indicate the advisability of selecting 5-in. pipe for the conditions of this problem.

The friction in pipe elbows may be expressed in terms of equivalent lengths of straight pipe. Elbows having the largest radius will naturally give the least friction and the accompanying table as given by the Norwalk Compressor Co. gives the friction effect of elbows in terms of the radius.

TABLE XVI.—FRICTION EFFECT OF ELBOWS IN TERMS OF PIPE LENGTHS

Radius of elbow in pipe diameters	5	3	2	1½	1¼	1	¾	½
Equivalent lengths of straight pipe in pipe diameters.	7.85	8.24	9.03	10.36	12.72	17.51	35.09	121.2

REHEATING

From a consideration of changes that take place during the compression and expansion of the air, it is apparent that heating the air just before expansion will raise its temperature and impart to it an increase of energy which, if used immediately, will increase the efficiency of the compressed air. In addition, this reheating will increase the temperature at the end of expansion and prevent the particles of moisture in the air from freezing.

It is not uncommon in the ordinary use of compressed air to find

exhaust temperature varying from 5° to 60° F. The lower temperature is very apt to cause trouble particularly in out-door work during the winter months. It is quite probable that reheating was

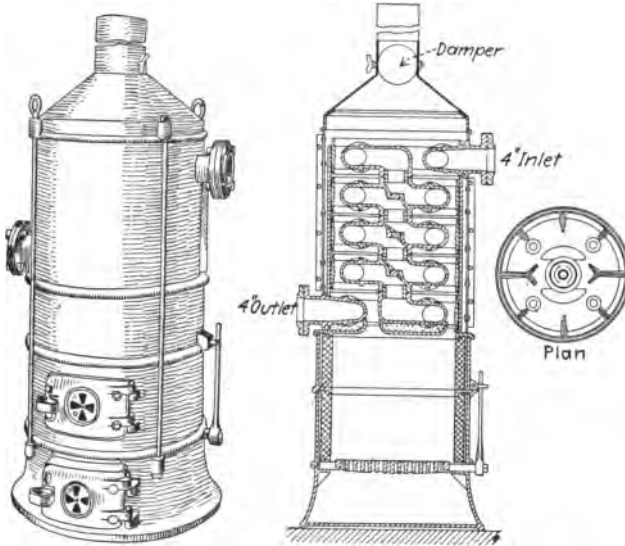

FIG. 142.—Sullivan air reheater.

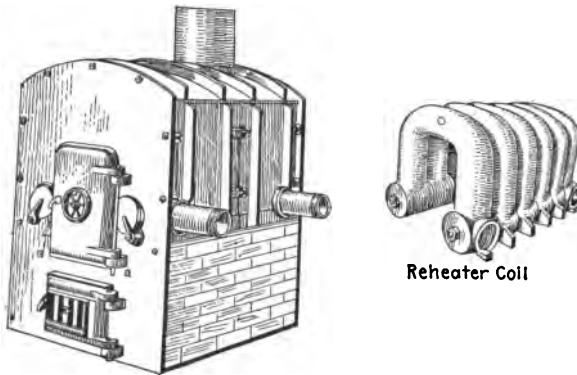

FIG. 143.—Leyner air reheater.

first introduced to prevent the formation of frost in the exhaust pipe and its advantages are so apparent that no economical use of compressed air in large installations is complete without some system of reheating.

Stoves.—In quarry work it is very common to make use of stoves,

such as are shown in Figs. 142 and 143, for heating the air just before its use in the drills. In locomotive work for mines and surface use, hot water is frequently used to heat the air. A recent locomotive built for the government for handling cars of explosives has a compound cylinder, expansion taking place in one to such a point as to bring the temperature below that of the atmosphere. The air then passes to the low-pressure cylinder through pipes in contact with the atmosphere and in this way its temperature and energy are increased.

Reheaters are usually capable of raising the temperature of the air to from 300 to 500° F., although common practice shows temperatures from 250 to 350°. In figuring on reheaters it is usual to assume that 1 lb. of coal will give from 8,000 to 10,000 B.t.u. to the air. As the specific heat is 0.0686 B.t.u., it is evident that 1 lb. of coal will heat 33 lb. of air or about 408 cu. ft. to a final temperature of 350°. As reheating increases the volume as well as the temperature, the economy in its use expansively is quite evident.

CHAPTER XV

THE SELECTION AND CARE OF AIR COMPRESSORS

It is difficult, if not impossible, to dictate the type of compressor that must be selected to suit certain conditions, as the importance of the various factors influencing the selection vary greatly in different localities; however, a brief statement of some of the factors to be considered may be of assistance.

Available Power.—The character of driving power available will usually determine the type of prime mover to be selected. The principal manufacturers of compressors have on the market the belt-driven, steam-driven, and electrical-driven machines, as well as those driven by gas engines or water turbines.

For small and intermittent demands it is difficult to make use of an economical steam engine for operating the compressor, and for this reason when belt power is available and suitable for the conditions of operation, the belt-driven compressor is to be preferred.

When the quantity of air to be compressed is large, it will usually be found advisable to install a steam or motor-driven compressor as this allows greater flexibility and economy of operation.

If this type of motive power is selected, a choice of different designs must be made. The straight-line type, equipped with proper energy-compensating devices to secure economy of steam consumption, has the advantage of simplicity and high mechanical efficiency. On the other hand, the duplex type appeals to many, for, if single-stage, it may be installed in sections and in this way future extensions can be made with minimum expense.

The pressures that are desired will determine whether the compressor is to be of the one-, two- or three-stage system; the first being usually selected for pressures below 80 lb. per square inch, the second for pressures from 80 to 500 lb., and the third for pressures from 500 to 1,000 lb. per square inch.

Valve Gear.—The price of fuel will influence largely the type of valve gear to be selected for a steam engine. If fuel is very cheap and its consumption comparatively unimportant, the simpler forms of valve gears are to be preferred. If, however, the economy of

fuel is of importance, the more complicated and expensive types, such as the Corliss, should be selected.

The plain slide valve, the independent cut-off valve, such as the Meyer, and the Corliss give steam consumptions which decrease in the order named. The last two types, particularly the Meyer, are quite common for steam-driven compressors.

In the mountainous sections of the country and in those parts where the supply of water-power is abundant, water-wheels or turbines are largely used as prime movers.

The distance from the source of power to the place where the compressed air is to be used will determine whether the water-wheel is to be coupled directly to a compressor or to an electrical generator which will generate current to be transmitted to an electrically driven compressor.

Both types are in use in the mining regions, some of the largest compressed-air installations being equipped with compressors driven directly by water wheels.

Within the last few years the method of compressing air by means of a waterfall without the use of any mechanical parts has increased to such proportions as to demand the attention of engineers connected with the installing of compressed-air equipments.

Air compressors driven by gas or gasoline engines are frequently used in quarries and other places where it may be desirable to move the compressing plant from point to point. Where gas can be obtained cheaply it makes a most desirable machine, because of the high efficiency of the gas engine. Within the last few years gas engines operated by the gases from blast furnaces have been developed to such an extent that many of the large blowing engines for Bessemer converters are operated in this way, giving compressed air to the converters and other places where used at a minimum expense.

In selecting any type of air compressor, particular attention should be paid to the construction and design of the valves. Mechanically operated inlet and automatically operated discharge valves seem at present to represent the favorite practice, although automatically operated inlet valves are preferred by many because of the little attention they require.

All valves should be simple in construction, of large port opening, durable and reliable in action, and easily removed for purposes of examination and renewal.

The largest possible amount of surface, including cylinder heads,

should be water-jacketed on all piston compressors except those discharging at very low pressures.

The nature of the work performed by the compressor will determine the advisability of installing an unloading or governing device, economy of operation usually demanding the installation of some such apparatus.

Size and Type of Compressor.—In order to give an idea of the data required when determining the size and type of a compressor to be selected, the following is given, as published by the Sullivan Machinery Company in their catalogue:

1. Purpose for which the compressed air is to be used (coal-mining machines, rock drills, air lift, etc.).
2. Volume of free air required in cubic feet per minute.
3. Working air pressure.
4. Altitude at which compressor will work, if over 1,000 ft. above the sea-level.
5. Number, size, and class of machines to be operated by the compressed air.
6. If the air is to be used for pumps, give make, size, and speed of pump and height to which water must be delivered.
7. If for raising water by the "air lift," state desired flow per minute in gallons, diameter and depth of well, and height to which water must be delivered, measuring the average height of water in the well.
8. Will the demand for air be constant or intermittent during the daily time of operation?
9. Will the compressor be operated by steam or power?
10. If steam driven, state working steam pressure, kind and average cost of fuel available, type of engine preferred and whether it is to be run condensing or non-condensing.
11. If power driven, state motive power (as water-power, electricity, rope driven, or gasoline engine) and whether direct connection, belt, or gearing is preferred.
12. If water-power is to be used, give horse-power available, or head or fall of water in feet, also amount of water supply in cubic feet per minute.
13. If belt drive is employed, give horse-power at belt.
14. State facilities for transporting compressor to destination. If machine must be sectionalized, state means of transportation, heaviest weight allowable for a single package and number of packages permissible of maximum weight.

COMPRESSED AIR EXPLOSIONS

“Compressed air claims to be and is a safe power. Occasionally we hear of a case of firing, which to some may appear to be a serious objection to the use of air; but if the causes are known and understood and due care is observed, firing becomes a matter of carelessness. Compressed air is not inflammable, but, during compression by piston compressors it is necessary to use oil for lubrication, and this oil or the gases from it form a combustible mixture with the air.

In most cases firing may be traced to the use of poor oil, but in others too much oil sometimes causes ignition.

Lubricating Compressors.—It is a common mistake of engineers to feed oil too rapidly to the air cylinders. A drop now and then is all that is required to keep the parts lubricated. The air cylinder does not require as much lubrication as the steam cylinder, for there is no tendency to cut and wash away the oil as there is in a steam cylinder.

When too much oil is used, there is a gradual accumulation of carbon which interferes with the free movement of the valves and which chokes the passages, so that a high temperature may for a moment be formed and ignition follow.

It is well to get the best oil and use but little of it.

There are cases where firing has arisen from the introduction of kerosene or naphtha into the air cylinder for the purpose of cleaning the valves and cutting away the carbon deposits. This is a very effective way of cleaning valves and pipes, but it is a source of danger and should be absolutely forbidden.

The inflammability of benzine, naphtha and kerosene is so acute that it is a dangerous experiment to introduce anything of this kind into an air cylinder.

Cleaning Valves.—Soft soap and water is the best cleanser for the air cylinder and it is recommended even in cases where the best oil is used and it is a good plan to fill the oil cup with soft soap and water and feed it into the cylinder, as the oil is fed, at least once or twice a week, or even oftener if necessary, in order to prevent the carbon deposit from gumming up the valves.

A thick or cheap grade of cylinder oil should never be used in an air compressor. Thin oil which has a high flash-point and which is as free from carbon as conditions of lubrication will admit is the best oil.

There may be considerable danger in a valve which is so gummed

as to be unable to close at the right time. When a piston has compressed air and forced it through the discharge valve and then starts on its return stroke, there is immediately a tendency for the air just compressed to return to the cylinder, and if the valve does not operate properly there will be some hot compressed air in the cylinder when the piston starts again on its compression stroke with air at an initial temperature, 200° or 300° above the normal. The final temperature at the end of compression will in consequence be quite high and may even be above the ignition point of the lubricating oil that is used.

To guard against this, care should be taken in the selection of the type of compressor used and the valves and passages should be thoroughly cleansed once a week by the engineer, who should also investigate the valve seats to insure the valve fitting properly when in place.

Inlet Connection.—The inlet should be closed in a cold-air box, or some direct connection should be made to the outside air in order to avoid taking in hot air to the compressor.

In compressors used in the coal-mining districts, care should be taken to see that coal-dust is not drawn into the cylinder.

A thermometer should be placed in the discharge pipe close to the compressor so that the operating engineer may note any change of temperature and stop or slow down the compressor to avoid an accident.

APPENDIX A

Common Logarithms.—The following table of common logarithms will be found of assistance in solving work and power problems dealing with compressed air.

The table shows the “mantissa” only, the “characteristic” depending on the location of the decimal point and being one less than the number of figures to the left of the decimal point of the given number. For example:

The logarithm of 529 is 2.7235

The logarithm of 52.9 is 1.7235

The logarithm of 5.29 is 0.7235

The logarithm of 0.529 is 9.7235—10

The logarithm of 0.0529 is 8.7235—10.

The table of proportional parts is for the purpose of interpolation. For example, if the log of 80.54 is desired it is found as follows: The log of 80.5 from the table is 1.9058. The table of proportional parts shows in the same line of figures the additional figure to be added under the column marked 4 to be 2, making the required log of 80.54 1.9058 plus 0.0002 or 1.9060.

Logs of powers of numbers are found by multiplying the log of the number by the given power or exponent. For example, suppose it is required to find the value of $28.3^{1.4}$.

The log of 28.3 is 1.4518, and this multiplied by 1.4 is 2.0325, that is, the log of $28.3^{1.4}$ is 2.0325.

The antilog of this or the numerical value of $28.3^{1.4}$ is found by looking in the table for the number whose logarithm has a “mantissa” of 0325 and then pointing off three places from the left or one more than the characteristic 2. The antilog of 2.0294 from the table is 107, and as the given log is 0.0031 higher than 2.0294 the table of proportional parts would indicate that the antilog of 2.0325 is about 0.75 higher than 107. That is $28.3^{1.4}$ is equal to 107.75.

The principal difficulty in handling logarithms of small numbers with fractional exponents is met in dealing with the characteristics. This may be treated as follows:

Suppose the value of $0.483^{0.42}$ is desired.

The log of 0.483 is 9.6839—10

LOGARITHMS.

Nat. Nos.	0	1	2	3	4	5	6	7	8	9	Proportional Parts.								
											1	2	3	4	5	6	7	8	9
10	0000	0043	0086	0128	0170	0212	0253	0294	0334	0374	4	8	12	17	21	25	29	33	37
11	0414	0453	0492	0531	0569	0607	0645	0682	0719	0755	4	8	11	15	19	23	26	30	34
12	0792	0828	0864	0899	0934	0969	1004	1038	1072	1106	3	7	10	14	17	21	24	28	31
13	1139	1173	1206	1239	1271	1303	1335	1367	1399	1430	3	6	10	13	16	19	23	26	29
14	1461	1492	1523	1553	1584	1614	1644	1673	1703	1732	3	6	9	12	15	18	21	24	27
15	1761	1790	1818	1847	1875	1903	1931	1959	1987	2014	3	6	8	11	14	17	20	22	25
16	2041	2068	2095	2122	2148	2175	2201	2227	2253	2279	3	5	8	11	13	16	18	21	24
17	2304	2330	2355	2380	2405	2430	2455	2480	2504	2529	2	5	7	10	12	15	17	20	22
18	2553	2577	2601	2625	2648	2672	2695	2718	2742	2765	2	5	7	9	12	14	16	19	21
19	2788	2810	2833	2856	2878	2900	2923	2945	2967	2989	2	4	7	9	11	13	16	18	20
20	3010	3032	3054	3075	3096	3118	3139	3160	3181	3201	2	4	6	8	11	13	15	17	19
21	3222	3243	3263	3284	3304	3324	3345	3365	3385	3404	2	4	6	8	10	12	14	16	18
22	3424	3444	3464	3483	3502	3522	3541	3560	3579	3598	2	4	6	8	10	12	14	15	17
23	3617	3636	3655	3674	3692	3711	3729	3747	3766	3784	2	4	6	7	9	11	13	15	17
24	3802	3820	3838	3856	3874	3892	3909	3927	3945	3962	2	4	5	7	9	11	12	14	16
25	3979	3997	4014	4031	4048	4065	4082	4099	4116	4133	2	3	5	7	9	10	12	14	15
26	4150	4166	4183	4200	4216	4232	4249	4265	4281	4298	2	3	5	7	8	10	11	13	15
27	4314	4330	4346	4362	4378	4393	4409	4425	4440	4456	2	3	5	6	8	9	11	13	14
28	4472	4487	4502	4518	4533	4548	4564	4579	4594	4609	2	3	5	6	8	9	11	12	14
29	4624	4639	4654	4669	4683	4698	4713	4728	4742	4757	1	3	4	6	7	9	10	12	13
30	4771	4786	4800	4814	4829	4843	4857	4871	4886	4900	1	3	4	6	7	9	10	11	13
31	4914	4928	4942	4955	4969	4983	4997	5011	5024	5038	1	3	4	6	7	8	10	11	12
32	5051	5065	5079	5092	5105	5119	5132	5145	5159	5172	1	3	4	5	7	8	9	11	12
33	5185	5198	5211	5224	5237	5250	5263	5276	5289	5302	1	3	4	5	6	8	9	10	12
34	5315	5328	5340	5353	5366	5378	5391	5403	5416	5428	1	3	4	5	6	8	9	10	11
35	5441	5453	5465	5478	5490	5502	5514	5527	5539	5551	1	2	4	5	6	7	9	10	11
36	5563	5575	5587	5599	5611	5623	5635	5647	5658	5670	1	2	4	5	6	7	8	10	11
37	5682	5694	5705	5717	5729	5740	5752	5763	5775	5786	1	2	3	5	6	7	8	9	10
38	5798	5809	5821	5832	5843	5855	5866	5877	5888	5899	1	2	3	5	6	7	8	9	10
39	5911	5922	5933	5944	5955	5966	5977	5988	5999	6010	1	2	3	4	5	7	8	9	10
40	6021	6031	6042	6053	6064	6075	6085	6096	6107	6117	1	2	3	4	5	6	8	9	10
41	6128	6138	6149	6160	6170	6180	6191	6201	6212	6222	1	2	3	4	5	6	7	8	9
42	6232	6243	6253	6263	6274	6284	6294	6304	6314	6325	1	2	3	4	5	6	7	8	9
43	6335	6345	6355	6365	6375	6385	6395	6405	6415	6425	1	2	3	4	5	6	7	8	9
44	6435	6444	6454	6464	6474	6484	6493	6503	6513	6522	1	2	3	4	5	6	7	8	9
45	6532	6542	6551	6561	6571	6580	6590	6599	6609	6618	1	2	3	4	5	6	7	8	9
46	6628	6637	6646	6656	6665	6675	6684	6693	6702	6712	1	2	3	4	5	6	7	7	8
47	6721	6730	6739	6749	6758	6767	6776	6785	6794	6803	1	2	3	4	5	5	6	7	8
48	6812	6821	6830	6839	6848	6857	6866	6875	6884	6893	1	2	3	4	4	5	6	7	8
49	6902	6911	6920	6928	6937	6946	6955	6964	6972	6981	1	2	3	4	4	5	6	7	8
50	6990	6998	7007	7016	7024	7033	7042	7050	7059	7067	1	2	3	3	4	5	6	7	8
51	7076	7084	7093	7101	7110	7118	7126	7135	7143	7152	1	2	3	3	4	5	6	7	8
52	7160	7168	7177	7185	7193	7202	7210	7218	7226	7235	1	2	2	3	4	5	6	7	7
53	7243	7251	7259	7267	7275	7284	7292	7300	7308	7316	1	2	2	3	4	5	6	6	7
54	7324	7332	7340	7348	7356	7364	7372	7380	7388	7396	1	2	2	3	4	5	6	6	7

LOGARITHMS.

Nat. Nos.	0	1	2	3	4	5	6	7	8	9	Proportional Parts.								
											1	2	3	4	5	6	7	8	9
55	7404	7412	7419	7427	7435	7443	7451	7459	7466	7474	1	2	2	3	4	5	5	6	7
56	7482	7490	7497	7505	7513	7520	7528	7536	7543	7551	1	2	2	3	4	5	5	6	7
57	7559	7566	7574	7582	7589	7597	7604	7612	7619	7627	1	2	2	3	4	5	5	6	7
58	7634	7642	7649	7657	7664	7672	7679	7686	7694	7701	1	1	2	3	4	4	5	6	7
59	7709	7716	7723	7731	7738	7745	7752	7760	7767	7774	1	1	2	3	4	4	5	6	7
60	7782	7789	7796	7803	7810	7818	7825	7832	7839	7846	1	1	2	3	4	4	5	6	6
61	7853	7860	7868	7875	7882	7889	7896	7903	7910	7917	1	1	2	3	4	4	5	6	6
62	7924	7931	7938	7945	7952	7959	7966	7973	7980	7987	1	1	2	3	3	4	5	6	6
63	7993	8000	8007	8014	8021	8028	8035	8041	8048	8055	1	1	2	3	3	4	5	5	6
64	8062	8069	8075	8082	8089	8096	8102	8109	8116	8122	1	1	2	3	3	4	5	5	6
65	8129	8136	8142	8149	8156	8162	8169	8176	8182	8189	1	1	2	3	3	4	5	5	6
66	8195	8202	8209	8215	8222	8228	8235	8241	8248	8254	1	1	2	3	3	4	5	5	6
67	8261	8267	8274	8280	8287	8293	8299	8306	8312	8319	1	1	2	3	3	4	5	5	6
68	8325	8331	8338	8344	8351	8357	8363	8370	8376	8382	1	1	2	3	3	4	4	5	6
69	8388	8395	8401	8407	8414	8420	8426	8432	8439	8445	1	1	2	2	3	4	4	5	6
70	8451	8457	8463	8470	8476	8482	8488	8494	8500	8506	1	1	2	2	3	4	4	5	6
71	8513	8519	8525	8531	8537	8543	8549	8555	8561	8567	1	1	2	2	3	4	4	5	5
72	8573	8579	8585	8591	8597	8603	8609	8615	8621	8627	1	1	2	2	3	4	4	5	5
73	8633	8639	8645	8651	8657	8663	8669	8675	8681	8686	1	1	2	2	3	4	4	5	5
74	8692	8698	8704	8710	8716	8722	8727	8733	8739	8745	1	1	2	2	3	4	4	5	5
75	8751	8756	8762	8768	8774	8779	8785	8791	8797	8802	1	1	2	2	3	3	4	5	5
76	8808	8814	8820	8825	8831	8837	8842	8848	8854	8859	1	1	2	2	3	3	4	5	5
77	8865	8871	8876	8882	8887	8893	8899	8904	8910	8915	1	1	2	2	3	3	4	4	5
78	8921	8927	8932	8938	8943	8949	8954	8960	8965	8971	1	1	2	2	3	3	4	4	5
79	8976	8982	8987	8993	8998	9004	9009	9015	9020	9025	1	1	2	2	3	3	4	4	5
80	9031	9036	9042	9047	9053	9058	9063	9069	9074	9079	1	1	2	2	3	3	4	4	5
81	9085	9090	9096	9101	9106	9112	9117	9122	9128	9133	1	1	2	2	3	3	4	4	5
82	9138	9143	9149	9154	9159	9165	9170	9175	9180	9186	1	1	2	2	3	3	4	4	5
83	9191	9196	9201	9206	9212	9217	9222	9227	9232	9238	1	1	2	2	3	3	4	4	5
84	9243	9248	9253	9258	9263	9269	9274	9279	9284	9289	1	1	2	2	3	3	4	4	5
85	9294	9299	9304	9309	9315	9320	9325	9330	9335	9340	1	1	2	2	3	3	4	4	5
86	9345	9350	9355	9360	9365	9370	9375	9380	9385	9390	1	1	2	2	3	3	4	4	5
87	9395	9400	9405	9410	9415	9420	9425	9430	9435	9440	0	1	1	2	2	3	3	4	4
88	9445	9450	9455	9460	9465	9469	9474	9479	9484	9489	0	1	1	2	2	3	3	4	4
89	9494	9499	9504	9509	9513	9518	9523	9528	9533	9538	0	1	1	2	2	3	3	4	4
90	9542	9547	9552	9557	9562	9566	9571	9576	9581	9586	0	1	1	2	2	3	3	4	4
91	9590	9595	9600	9605	9609	9614	9619	9624	9628	9633	0	1	1	2	2	3	3	4	4
92	9638	9643	9647	9652	9657	9661	9666	9671	9675	9680	0	1	1	2	2	3	3	4	4
93	9685	9689	9694	9699	9703	9708	9713	9717	9722	9727	0	1	1	2	2	3	3	4	4
94	9731	9736	9741	9745	9750	9754	9759	9763	9768	9773	0	1	1	2	2	3	3	4	4
95	9777	9782	9786	9791	9795	9800	9805	9809	9814	9818	0	1	1	2	2	3	3	4	4
96	9823	9827	9832	9836	9841	9845	9850	9854	9859	9863	0	1	1	2	2	3	3	4	4
97	9868	9872	9877	9881	9886	9890	9894	9899	9903	9908	0	1	1	2	2	3	3	4	4
98	9912	9917	9921	9926	9930	9934	9939	9943	9948	9952	0	1	1	2	2	3	3	4	4
99	9956	9961	9965	9969	9974	9978	9983	9987	9991	9996	0	1	1	2	2	3	3	4	4

The log of $0.483^{0.42}$ is found by multiplying the log by the exponent or 0.42 ($9.6839 - 10$) which is $4.067238 - 4.2$. It is difficult to get the antilog of this directly, but the value of the logarithm is not changed if a number be added to the first part and subtracted from the second part to make this -10 . In this case add 5.8 to the first and subtract 5.8 from the second, making the log of $0.483^{0.42}$ $9.8672 - 10$.

The antilog of this is 0.736 plus 0.0004 or 0.7364.

That is, $0.483^{0.42}$ is equal to 0.7364.

APPENDIX B

Naperian Logarithms.—The natural, hyperbolic or naperian logarithm of a number can be found by multiplying the common logarithm of the number by 2.3026 but the solution of problems involving this log or the \log_e as it is written will be facilitated by the use of the following tables which read from 1 to 10 by increments of hundredths.

For example, the \log_e of 4.36 is given directly as 1.4725.

Characteristics and mantissas are not handled in this table in the same way as the common logs. But as the log of 43.6 is the same as the \log_e of 4.36×10 this may be found by adding the \log_e of 4.36 and 10. In this case this is the sum of 1.4725 and 2.3026 or 3.7151. That is, the \log_e of 43.6 is 3.7151.

In the same way the \log_e of .436 is the same as the \log_e of (4.36 divided by 10) or the \log_e of 4.36 minus the \log_e of 10. In this case it is $1.4725 - 2.3026$ or -0.8301 . That is the \log_e of 0.436 is -0.8301 , a negative number.

APPENDIX B

$e = 2.7182818$ $\log e = 0.4342945 - M$

	0	1	2	3	4	5	6	7	8	9
1.0	0.0000	0.00995	0.01980	0.02956	0.03922	0.04879	0.05827	0.06766	0.07696	0.08618
1.1	0.09531	0.1044	0.1133	0.1222	0.1310	0.1398	0.1484	0.1570	0.1655	0.1739
1.2	0.1823	0.1906	0.1988	0.2070	0.2151	0.2231	0.2311	0.2390	0.2469	0.2546
1.3	0.2624	0.2700	0.2776	0.2852	0.2927	0.3001	0.3075	0.3148	0.3221	0.3293
1.4	0.3365	0.3436	0.3507	0.3577	0.3646	0.3716	0.3784	0.3853	0.3920	0.3988
1.5	0.4055	0.4121	0.4187	0.4253	0.4318	0.4382	0.4447	0.4511	0.4574	0.4637
1.6	0.4700	0.4762	0.4824	0.4886	0.4947	0.5008	0.5068	0.5128	0.5188	0.5247
1.7	0.5306	0.5365	0.5423	0.5481	0.5539	0.5596	0.5653	0.5710	0.5766	0.5822
1.8	0.5878	0.5933	0.5988	0.6043	0.6098	0.6152	0.6206	0.6259	0.6313	0.6366
1.9	0.6418	0.6471	0.6523	0.6575	0.6627	0.6678	0.6729	0.6780	0.6831	0.6881
2.0	0.6931	0.6981	0.7031	0.7080	0.7129	0.7178	0.7227	0.7275	0.7324	0.7372
2.1	0.7419	0.7467	0.7514	0.7561	0.7608	0.7655	0.7701	0.7747	0.7793	0.7839
2.2	0.7884	0.7930	0.7975	0.8020	0.8065	0.8109	0.8154	0.8198	0.8242	0.8286
2.3	0.8329	0.8372	0.8416	0.8459	0.8502	0.8544	0.8587	0.8629	0.8671	0.8713
2.4	0.8755	0.8796	0.8838	0.8879	0.8920	0.8961	0.9002	0.9042	0.9083	0.9123
2.5	0.9163	0.9203	0.9243	0.9282	0.9322	0.9361	0.9400	0.9439	0.9478	0.9517
2.6	0.9555	0.9594	0.9632	0.9670	0.9708	0.9746	0.9783	0.9821	0.9858	0.9895
2.7	0.9933	0.9969	1.0006	1.0043	1.0080	1.0116	1.0152	1.0188	1.0225	1.0260
2.8	1.0296	1.0332	1.0367	1.0403	1.0438	1.0473	1.0508	1.0543	1.0578	1.0613
2.9	1.0647	1.0682	1.0716	1.0750	1.0784	1.0818	1.0852	1.0886	1.0919	1.0953
3.0	1.0986	1.1019	1.1053	1.1086	1.1119	1.1151	1.1184	1.1217	1.1249	1.1282
3.1	1.1314	1.1346	1.1378	1.1410	1.1442	1.1474	1.1506	1.1537	1.1569	1.1600
3.2	1.1632	1.1663	1.1694	1.1725	1.1756	1.1787	1.1817	1.1848	1.1878	1.1909
3.3	1.1939	1.1969	1.2000	1.2030	1.2060	1.2090	1.2119	1.2149	1.2179	1.2208
3.4	1.2238	1.2267	1.2296	1.2326	1.2355	1.2384	1.2413	1.2442	1.2470	1.2499
3.5	1.2528	1.2556	1.2585	1.2613	1.2641	1.2669	1.2698	1.2726	1.2754	1.2782
3.6	1.2809	1.2837	1.2865	1.2892	1.2920	1.2947	1.2975	1.3002	1.3029	1.3056
3.7	1.3083	1.3110	1.3137	1.3164	1.3191	1.3218	1.3244	1.3271	1.3297	1.3324
3.8	1.3350	1.3376	1.3403	1.3429	1.3455	1.3481	1.3507	1.3533	1.3558	1.3584
3.9	1.3610	1.3635	1.3661	1.3686	1.3712	1.3737	1.3762	1.3788	1.3813	1.3838
4.0	1.3863	1.3888	1.3913	1.3938	1.3962	1.3987	1.4012	1.4036	1.4061	1.4085
4.1	1.4110	1.4134	1.4159	1.4183	1.4207	1.4231	1.4255	1.4279	1.4303	1.4327
4.2	1.4351	1.4375	1.4398	1.4422	1.4446	1.4469	1.4493	1.4516	1.4540	1.4563
4.3	1.4586	1.4609	1.4633	1.4656	1.4679	1.4702	1.4725	1.4748	1.4770	1.4793
4.4	1.4816	1.4839	1.4861	1.4884	1.4907	1.4929	1.4951	1.4974	1.4996	1.5019
4.5	1.5041	1.5063	1.5085	1.5107	1.5129	1.5151	1.5173	1.5195	1.5217	1.5239
4.6	1.5261	1.5282	1.5304	1.5326	1.5347	1.5369	1.5390	1.5412	1.5433	1.5454
4.7	1.5476	1.5497	1.5518	1.5539	1.5560	1.5581	1.5602	1.5623	1.5644	1.5665
4.8	1.5686	1.5707	1.5728	1.5748	1.5769	1.5790	1.5810	1.5831	1.5851	1.5872
4.9	1.5892	1.5913	1.5933	1.5953	1.5974	1.5994	1.6014	1.6034	1.6054	1.6074
5.0	1.6094	1.6114	1.6134	1.6154	1.6174	1.6194	1.6214	1.6233	1.6253	1.6273
5.1	1.6292	1.6312	1.6332	1.6351	1.6371	1.6390	1.6409	1.6429	1.6448	1.6467
5.2	1.6487	1.6506	1.6525	1.6544	1.6563	1.6582	1.6601	1.6620	1.6639	1.6658
5.3	1.6677	1.6696	1.6715	1.6734	1.6752	1.6771	1.6790	1.6808	1.6827	1.6845
5.4	1.6864	1.6882	1.6901	1.6919	1.6938	1.6956	1.6974	1.6993	1.7011	1.7029
5.5	1.7047	1.7066	1.7084	1.7102	1.7120	1.7138	1.7156	1.7174	1.7192	1.7210
5.6	1.7228	1.7246	1.7263	1.7281	1.7299	1.7317	1.7334	1.7352	1.7370	1.7387

APPENDIX C

HYGROMETRY¹

Hygrometry is the measurement of the amount of water vapor in the atmosphere. There is always more or less water vapor in the atmosphere depending on its temperature and its degree of saturation. The study of hygrometry is of increasing importance. It has been found by experience that the moisture in air has a marked effect on many industrial processes, such as the spinning of cotton, the smelting of iron in blast furnaces and the ventilation of factories and other buildings. It is also necessary to know the amount of moisture present in all measurement of air or gases and in tests of machinery for handling the same.

According to Dalton's law, when a mixture of two gases fills a space of, say, 1 cu. ft., the pressure in the space is the sum of the two pressures that would be produced by a cubic foot of each of the gases alone at the same temperature. In the same manner a mixture of air and vapor has a pressure which is the sum of the pressure of an equal volume of dry air, and of vapor alone, each at the given temperature of the mixture. Air and vapor occur in mixtures varying from practically dry air to a state of saturation such that any addition to the mixture of vapor at the same temperature causes a portion to condense. To every temperature there corresponds a certain water-vapor pressure or partial pressure which may be found in steam tables such as "Marks and Davis" or "Peabody's."

Air in actual practice rarely contains vapor with 100 per cent. saturation and the weight of water vapor present is less than the maximum for that temperature of air. The air is then said to be only partially saturated, and the degree of saturation is expressed by the ratio of the weight of water vapor actually contained in a given space to the maximum weight that the space can contain under the conditions of absolute pressures and temperatures existing at that time. This ratio is known as the "Relative Humidity."

Absolute Humidity.—The absolute humidity is the weight of water

¹ Christie's and Kowalke's Steam and Gas Engineering Laboratory Notes.

vapor that 1 cu. ft. actually contains under the given pressure and temperature conditions.

Relative Humidity.—Relative humidity is usually determined by means of psychrometers or wet- and dry-bulb thermometers. These consist of two thermometers fastened to a frame and placed in a current of air. The bulb of one thermometer is kept covered with cotton wick and is kept thoroughly wet with water at room temperature. If the air is not saturated, evaporation will take place from the wet bulb and its temperature will be lowered by the abstraction of the latent heat of the water. This lowering of the temperature has been found to be a measure of the relative humidity.

Psychrometers.—Psychrometers are made in two types, stationary and sling. In the sling psychrometer the wick is moistened and the whole frame whirled around by a handle for 15 or 20 seconds. The wet bulb thermometer is read immediately after stopping. By the use of Chart A of the accompanying diagram the relative humidity may be obtained from the readings of the two thermometers. For example, if the dry-bulb thermometer shows a reading of 72° and the wet bulb 61° , or a difference of 11° , the relative humidity is 52.6 per cent., if the atmospheric pressure is 30 in. of mercury. If the atmospheric pressure is 28 in. the chart reading should be increased $2 \times 1/100$ of 52.6 or 1.05, making the corrected relative humidity 53.65 per cent.

In making accurate measurements of air it is necessary to determine carefully the weight of moisture present in the atmosphere and the volume occupied by this vapor. In order to do this, reference is made to data regarding the density of vapor at various temperatures and pressures. This information is given in most steam tables and the following figures have been taken from Marks and Davis tables. The density or weight of the vapor per cubic foot is shown graphically in Chart C of the large diagram as the line marked 100 per cent. This same chart also shows weights of the vapor to be used in calculations with air of various humidities, as shown in the example following the tables.

01
 pressure
 ure of d
 erted vaj
 ent Hun
 rature i
 t of one
 t of one
 ction to
 of math
 ic heat
 ic heat
 ic heat d

y Air:
 $w_0 = \frac{1}{6}$
 14.0×10^4
 4536^*
 $q_0 = 14.0$
 4536^*
 $=(S_0) + 0$
 $w_0 = 10$

ure (10⁴)
 0.0705

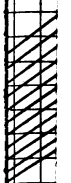

0.0705

III
 S.

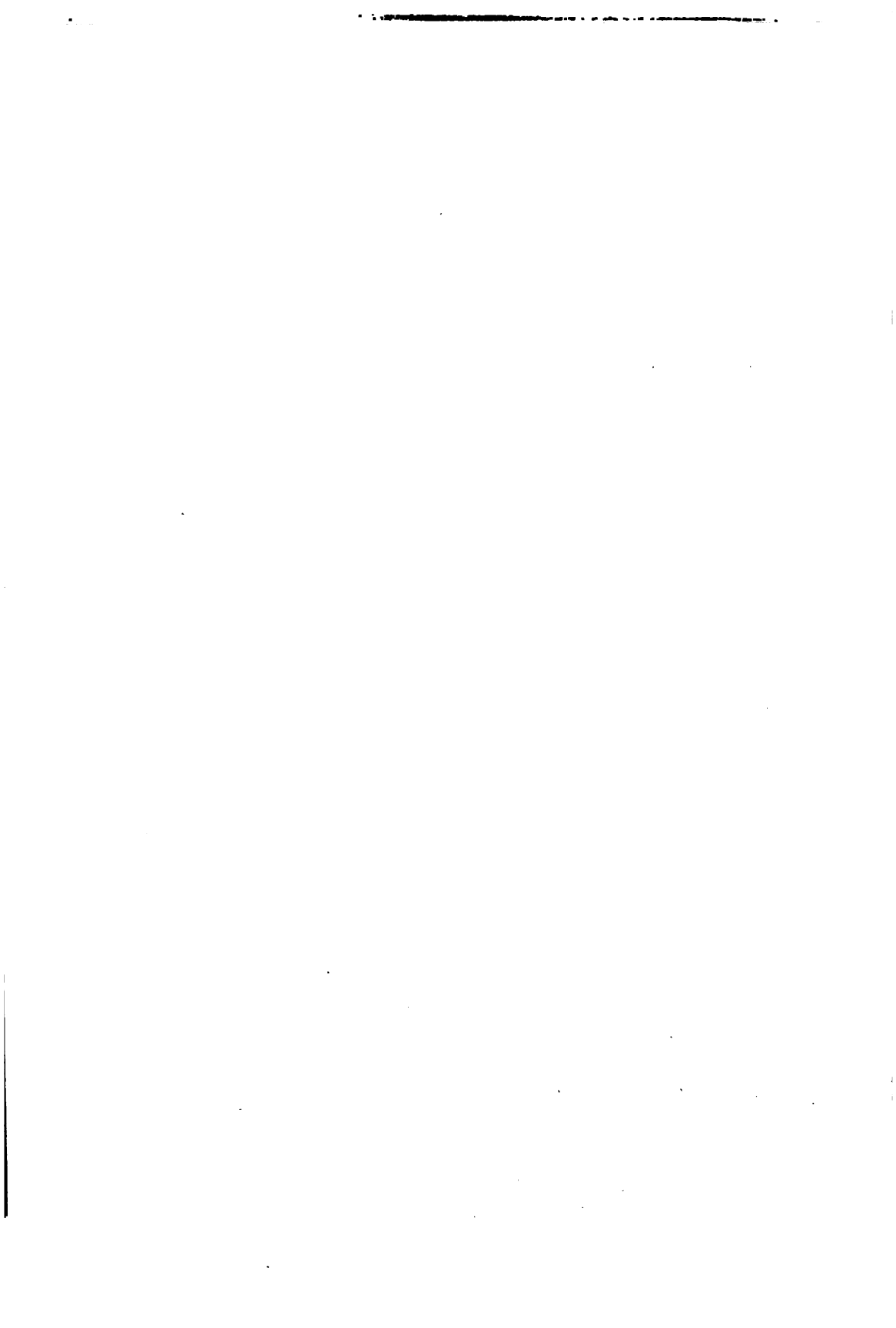

Tables showing the temperature, pressure, specific volume and density of steam or water vapor from 32° to 219° F., condensed from Marks' and Davis' Steam Tables by permission of the publishers, Longmans, Green & Co.

Temperature Fahrenheit	Pressure		Specific vol., cubic feet per pound	Density, pounds per cubic foot
	Pounds per square inch	Inches mercury		
32	0.0886	0.1804	3,294	0.000304
33	0.0922	0.1878	3,170	0.000316
34	0.0960	0.1955	3,052	0.000328
35	0.0999	0.2034	2,938	0.000340
36	0.1040	0.2117	2,829	0.000353
37	0.1081	0.2202	2,725	0.000367
38	0.1125	0.2290	2,626	0.000381
39	0.1170	0.2382	2,530	0.000395
40	0.1217	0.2477	2,438	0.000410
41	0.1265	0.2575	2,350	0.000425
42	0.1315	0.2677	2,266	0.000441
43	0.1366	0.2782	2,185	0.000458
44	0.1420	0.2890	2,107	0.000475
45	0.1475	0.3002	2,033	0.000492
46	0.1532	0.3118	1,961	0.000510
47	0.1591	0.3238	1,892	0.000529
48	0.1651	0.3363	1,826	0.000548
49	0.1715	0.3492	1,763	0.000567
50	0.1780	0.3625	1,702	0.000587
51	0.1848	0.3762	1,643	0.000608
52	0.1917	0.3903	1,586	0.000630
53	0.1989	0.4049	1,532	0.000653
54	0.2063	0.4201	1,480	0.000676
55	0.2140	0.4357	1,430	0.000700
56	0.2219	0.4518	1,381	0.000724
57	0.2301	0.4684	1,335	0.000749
58	0.2385	0.4856	1,291	0.000775
59	0.2472	0.5034	1,249	0.000801

Temperature Fahrenheit	Pressure		Specific vol., cubic feet per pound	Density, pounds per cubic foot
	Pounds per square inch	Inches mercury		
60	0.2562	0.522	1,208	0.000828
61	0.2654	0.541	1,168	0.000856
62	0.2749	0.560	1,130	0.000885
63	0.2847	0.580	1,093	0.000915
64	0.2949	0.601	1,058	0.000946
65	0.3054	0.622	1,024	0.000977
66	0.3161	0.644	991	0.001009
67	0.3272	0.667	959	0.001043
68	0.3386	0.690	928	0.001077
69	0.3504	0.714	899	0.001112
70	0.3626	0.739	871	0.001148
71	0.3751	0.764	843	0.001186
72	0.3880	0.790	817	0.001224
73	0.4012	0.817	792	0.001263
74	0.4148	0.845	767	0.001304
75	0.4288	0.873	743	0.001346
76	0.4432	0.903	720	0.001389
77	0.4581	0.933	698	0.001433
78	0.4735	0.964	677	0.001477
79	0.4893	0.996	657	0.001523
80	0.505	1.029	636.8	0.001570
81	0.522	1.063	617.5	0.001619
82	0.539	1.098	598.7	0.001670
83	0.557	1.134	580.5	0.001723
84	0.575	1.171	562.9	0.001777
85	0.594	1.209	545.9	0.001832
86	0.613	1.248	529.5	0.001889
87	0.633	1.289	513.7	0.001947
88	0.654	1.331	498.4	0.002007
89	0.675	1.373	483.6	0.002068
90	0.696	1.417	469.3	0.002131
91	0.718	1.462	455.5	0.002195
92	0.741	1.508	442.2	0.002261
93	0.765	1.556	429.4	0.002329
94	0.789	1.605	417.0	0.002398

Temperature Fahrenheit	Pressure		Specific vol., cubic feet per pound	Density, pounds per cubic foot
	Pounds per square inch	Inches mercury		
95	0.813	1.655	405.0	0.002469
96	0.838	1.706	393.4	0.002542
97	0.864	1.759	382.2	0.002617
98	0.891	1.813	371.4	0.002693
99	0.918	1.869	360.9	0.002771
100	0.946	1.926	350.8	0.002851
101	0.975	1.985	341.0	0.002933
102	1.005	2.045	331.5	0.003017
103	1.035	2.107	322.2	0.003104
104	1.066	2.171	313.3	0.003192
105	1.098	2.236	304.7	0.003282
106	1.131	2.303	296.4	0.003374
107	1.165	2.372	288.3	0.003469
108	1.199	2.443	280.5	0.003565
109	1.235	2.515	272.9	0.003664
110	1.271	2.589	265.5	0.003766
111	1.308	2.665	258.3	0.003871
112	1.346	2.740	251.4	0.003978
113	1.386	2.822	244.7	0.004087
114	1.426	2.904	238.2	0.004198
115	1.467	2.987	231.9	0.004312
116	1.509	3.073	225.8	0.004429
117	1.553	3.161	219.9	0.004548
118	1.597	3.252	214.1	0.004671
119	1.642	3.344	208.5	0.004796
120	1.689	3.438	203.1	0.004924
121	1.736	3.535	197.9	0.005054
122	1.785	3.635	192.8	0.005187
123	1.835	3.737	187.9	0.005323
124	1.886	3.841	183.1	0.005462
125	1.938	3.948	178.4	0.005605
126	1.992	4.057	173.9	0.005751
127	2.047	4.168	169.6	0.005900
128	2.103	4.282	165.3	0.006052
129	2.160	4.399	161.1	0.006207

Temperature Fahrenheit	Pressure		Specific vol., cubic feet per pound	Density, pounds per cubic foot
	Pounds per square inch	Inches mercury		
130	2.219	4.52	157.1	0.00637
131	2.279	4.64	153.2	0.00653
132	2.340	4.76	149.4	0.00669
133	2.403	4.89	145.8	0.00686
134	2.467	5.02	142.2	0.00703
135	2.533	5.16	138.7	0.00721
136	2.600	5.29	135.4	0.00739
137	2.669	5.43	132.1	0.00757
138	2.740	5.58	128.9	0.00776
139	2.812	5.73	125.8	0.00795
140	2.885	5.88	122.8	0.00814
141	2.960	6.03	119.9	0.00834
142	3.037	6.18	117.1	0.00854
143	3.115	6.34	114.3	0.00875
144	3.195	6.51	111.6	0.00896
145	3.277	6.67	109.0	0.00918
146	3.361	6.84	106.5	0.00940
147	3.446	7.02	104.0	0.00962
148	3.533	7.20	101.6	0.00985
149	3.623	7.38	99.2	0.01008
150	3.714	7.57	96.9	0.01032
151	3.809	7.76	94.7	0.01056
152	3.902	7.95	92.6	0.01080
153	3.999	8.14	90.5	0.01105
154	4.098	8.34	88.4	0.01131
155	4.199	8.55	86.4	0.01157
156	4.303	8.76	84.5	0.01184
157	4.408	8.98	82.6	0.01211
158	4.515	9.20	80.7	0.01239
159	4.625	9.42	78.9	0.01267
160	4.737	9.65	77.2	0.01296
161	4.851	9.88	75.5	0.01325
162	4.967	10.12	73.8	0.01355
163	5.086	10.36	72.2	0.01386
164	5.208	10.61	70.6	0.01417

Temperature Fahrenheit	Pressure		Specific vol., cubic feet per pound	Density, pounds per cubic foot
	Pounds per square inch	Inches mercury		
165	5.333	10.86	69.1	0.01448
166	5.460	11.12	67.6	0.01480
167	5.589	11.38	66.1	0.01513
168	5.721	11.65	64.7	0.01546
169	5.855	11.92	63.3	0.01580
170	5.992	12.20	62.0	0.01614
171	6.131	12.48	60.7	0.01649
172	6.273	12.77	59.4	0.01685
173	6.417	13.07	58.1	0.01721
174	6.564	13.37	56.9	0.01758
175	6.714	13.67	55.7	0.01796
176	6.867	13.98	54.5	0.01834
177	7.023	14.30	53.4	0.01873
178	7.182	14.62	52.3	0.01912
179	7.344	14.95	51.2	0.01953
180	7.51	15.29	50.15	0.01994
181	7.68	15.63	49.12	0.02036
182	7.85	15.98	48.12	0.02078
183	8.02	16.34	47.14	0.02121
184	8.20	16.70	46.18	0.02165
185	8.38	17.07	45.25	0.02210
186	8.57	17.45	44.34	0.02255
187	8.76	17.83	43.45	0.02301
188	8.95	18.22	42.59	0.02348
189	9.14	18.61	41.74	0.02396
190	9.34	19.02	40.91	0.02444
191	9.54	19.43	40.10	0.02493
192	9.74	19.83	39.31	0.02544
193	9.95	20.27	38.54	0.02595
194	10.17	20.71	37.78	0.02647
195	10.39	21.15	37.04	0.02700
196	10.61	21.60	36.32	0.02753
197	10.83	22.05	35.62	0.02807
198	11.06	22.52	34.93	0.02863
199	11.29	22.99	34.26	0.02919

Temperature Fahrenheit	Pressure		Specific vol., cubic feet per pound	Density, pounds per cubic foot
	Pounds per square inch	Inches mercury		
200	11.52	23.47	33.60	0.02976
201	11.76	23.95	32.96	0.03034
202	12.01	24.45	32.33	0.03093
203	12.26	24.96	31.72	0.03153
204	12.51	25.48	31.12	0.03214
205	12.77	26.00	30.53	0.03276
206	13.03	26.53	29.95	0.03339
207	13.30	27.08	29.39	0.03402
208	13.57	27.63	28.85	0.03466
209	13.85	28.19	28.32	0.03531
210	14.13	28.76	27.80	0.03597
211	14.41	29.33	27.29	0.03664
212	14.70	29.92	26.79	0.03732
213	14.99	30.52	26.30	0.03802
214	15.29	31.15	25.82	0.03873

Partial Pressures.—Suppose, for example, the barometers read 29.214 in. of mercury at a temperature of 78° F. Chart F of the diagram shows that at this temperature 1 in. of mercury corresponds to a pressure of 0.4889 lb. per square inch. That is, the barometer reading of 29.214 in. of mercury corresponds to an absolute pressure of 14.2827 lb. per square inch. If the air is saturated with moisture at 78° F., the pressure exerted by this vapor is, as shown from the tables of Marks and Davis, 0.4735 lb. per square inch. The pressure of the dry air present would then be 14.2827—0.4735 or 13.8092 lb. per square inch.

Suppose the psychrometer shows a relative humidity of 40 per cent. As the vapor pressures are proportional to the absolute weights, the pressure exerted by the moisture in the air will be 40 per cent. of 0.4735 or 0.1894 lb. per square inch. In this case the pressure due to the dry air present will be

$$14.2827 - 0.1894 \text{ or } 14.0933 \text{ lb. per square inch.}$$

If it is necessary to find the weight of a cubic foot of this moist air, this can be found by adding the weight of the cubic foot of dry

air at its pressure and temperature to the weight of the vapor present.

The weight of vapor present is found by multiplying the weight of a cubic foot of vapor at the given temperature by the relative humidity. The tables show that 78° F., the weight of a cubic foot of vapor, is 0.001477. The weight of the vapor present in the example is 40 per cent. $\times 0.001477$ or 0.000591 lb.

The weight of dry air present is found from the formula

$$\frac{P_1 V_1}{53.3 T_1} = w = \frac{144 \times 14.0933}{53.3(460 + 78)} = 0.070773$$

The weight per cubic foot of the air and its accompanying vapor is

$$0.000591 + 0.070773 = 0.071364.$$

This calculation can be made quite simply by referring to the various charts of the large diagram. By referring to Chart D it will be seen that the weight of air at 40 per cent. relative humidity and 78° F. is .06992 lb. per cubic foot if the pressure of the atmosphere is 14 lb. per square inch. In the example given the pressure is 14.2827 lb. per square inch. By referring to Chart E it will be seen that for the pressure of 14.2827 and temperature of 78° F. a correction of 0.00144 should be added making the weight per cubic foot of this mixture

$$0.06992 + 0.00144 \text{ or } .07136 \text{ lb. per cubic foot.}$$

When it is desired to measure air with a Thomas electric meter, the mean specific heat of the mixture of air and water vapor must be known. W. H. Carrier in his paper "Rational Psychrometric Formulæ," *Journal A. S. M. E.*, Nov., 1911, gives the following values which represent the results of the more recent investigations on the specific heat of air and water vapor. Instantaneous specific heat of air

$$C_{pa} = 0.24112 + 0.00009t$$

where t is the temperature in degrees Fahrenheit; and the instantaneous specific heat of water vapor as approximately

$$C_{ps} = 0.4423 + 0.00018t$$

where t is the temperature in degrees Fahrenheit.

Applying these formulæ to the example given with temperature of 78, C_{pa} is 0.241822 and C_{ps} is 0.45634.

The mean specific heat can then be found by multiplying the weight of each substance in the mixture by its specific heat, adding the products, and dividing the sum by the weight of the mixture. Thus

$$\begin{array}{r} \text{For the air,} \quad 0.070773 \times 0.241822 = 0.017114 \\ \text{For the moisture, } 0.000591 \times 0.45634 = \underline{0.000270} \\ \qquad \qquad \qquad \qquad \qquad \qquad \qquad \qquad \qquad 0.017384 \end{array}$$

Mean specific heat is $0.017384 \div 0.071364$ or 0.2436 .

The mean specific heat may also be obtained by referring to Chart B of the large diagram. This shows that for the given temperature of 78° F. and a relative humidity of 40 per cent. the mean specific heat may be taken as 0.2435 .

The above principles are applied commercially in testing steam condensers. An accurate thermometer is placed in the suction to the dry air pump and a mercury column attached to the same. In a condenser the conditions are such that the mixture is always saturated. Hence the pressure due to water vapor passing to the air pump will equal that due to its temperature as given in the steam tables. Then the difference between this pressure and that shown by the mercury column will equal the pressure due to the dry air in the mixture. If the volumetric efficiency of the air pump is known, the amount of air pumped can be computed, and this gives a means of readily checking the condensing equipment for air leakage.

The large diagram containing Charts A, B, C, D, E, F and G was prepared by W. C. Rowse, Instructor in the Steam and Gas Engineering Department of the University of Wisconsin.

INDEX

- Absolute humidity, 191
 - temperature, 5
 - zero, 6
- Action of piston compressor, 70
- Actual card of piston compressor, 78
 - compression, 75
- Advantage of isothermal compressor, 25
 - of multi-stage compressor, 90
- Air, 1
 - at low pressures, 38, 68
 - at pressures below the atmosphere, 26,-68
 - composition, 1
 - characteristics, 1-4
 - and energy equations, 10-17
 - compressor cards, 75
 - discharge valve, 102
 - density at various pressures, 174
 - dry, 4
 - for cupolas, 39
 - for forges, 39
 - for ventilation, 39, 40
 - free, 2
 - humidity, 2-6
 - internal energy, 6, 7, 16
 - in water, 29
 - inlet valve, 101
 - measurement, 160-171
 - pump, Edwards, 31
 - U. S. Navy, 30
 - supply for various buildings and rooms, 40
- Allis Chalmers fan, 65
- Altitude effect, 140-144
- Anemometers, 43
- Apparatus for measuring large quantities of air, 166
- Apparent specific heat, 8
 - volumetric efficiency, 77
- Area of inlet valves, 100
 - of discharge valves, 101
 - of fan blast, 43, 62
- Arrangements for coupling turbo-blowers, 125
- Arthur compressor, 132
- Arthur, Thomas, 132
- Automatic valves, 100
- Available power, 179
- Axial discharge fan, 41
 - thrust, balancing, 121
- Balancing axial thrust, 121
 - Rateau impellers, 122
 - by balancing piston, 123
 - by counter position, 121
 - by diminishing back area, 122
- Baloche and Krahnass compressor, 131, 132
- Belt regulator, 105, 107
- Blast area, fans, 43, 62
- Blower capacities, 50
 - cross section, 50
 - definitions, 42
 - efficiency, 81
 - losses, 81
 - mixing, 127
 - Parsons, 114
 - pressures, 50
 - Rateau, 114
- Blowing engine, 41
- Blowers, 41
- Boyle's law, 10
- Brake horse-power for fans, 58, 60, 66
- Brauer's method of constructing exponential curves, 19
- Brown, Boveri and Co. turbo-compressor, 117
- British thermal unit, 6
- Buildings, air required, 40
- Calculated and actual horse-power required for single stage compression, 74
- Capacity of blowers, 50
 - of fans, 42
 - of intercoolers, 93, 94

- Capacity of receivers, 160
 Card of piston compressor, actual. 78
 ideal, 77
 Cards, combined two-stage, 147
 clearance unloader, 112
 from air compressors, 70, 75
 showing adiabatic and isothermal compression, 73
 Carrier, W. H., 199
 Centrifugal fans, 38-65
 Channing, J. Parke, 144
 Characteristic and energy equations
 for air, 10-17
 equation for perfect gas, 10
 Characteristics of air, 1-4
 Christie, A. G., 191
 Classification of fans and blowers, 41
 of valves, 98
 Clayton governor, 109
 Cleaning valves, 182
 Clearance effect, 70, 71, 96, 97, 99
 methods of reducing, 71
 unloader, 110, 112
 cards, 112
 Coefficient of contraction, 43
 of efflux, 43, 56
 of velocity, 43
 Combined cards, two-stage compressor, 147
 governor and regulator, 109
 Common logarithms, 184-186
 Comparative effect of altitude on output, 143
 Compensator, hydraulic, 83
 lever, 83, 84
 weight, 83
 Composition of air, 1
 Compressed air explosions, 182
 Compression, actual, 75
 isothermal, 25
 line, 73
 wet and dry, 74
 exponential, 23
 Compressor, direct-acting steam, 82
 low pressure, 38
 tests, 144, 158
 Computation of internal or intrinsic energy, 16
 Concentration of liquors, 34
 Condenser pumps, 27
 Cone wheel fans, 65, 66
 Constants for pipe formulæ, 174, 175
 Construction of equilateral hyperbola, 18, 19
 of exponential curves, 19
 of isothermal curves, 18
 Contraction, coefficient of, 43
 Cooling capacity, 93
 devices, 117
 surface, 93
 turbo-compressors, 115
 Cost of Taylor compressor at Ainsworth, B. C., 136
 Coupling compressors, 124
 Cross-section, standard blower, 50
 piston compressor, 69
 Cupolas, air required, 39
 Cutler-Hammer Co., 161
 Cylinder efficiency, 80
 D'Auria system of energy compensation, 83
 Dalton's law, 191
 Davis, G. J., 164
 Definitions, fundamental, 5-9
 for fans and blowers, 42
 Density of air for various pressures, 174
 of water vapor, 193-198
 Description of fans, 58
 Design of fans, 58, 67
 of turbo-compressors, 113
 Details of piston air compressors, 98-110
 Developed section of Parsons blades, 115
 Devices, cooling, 117
 Diagram, three stage piston compressor, 116
 turbo-compressor, 116
 Diagrammatic sketch of Thomas electric meter, 169
 Diagrams, graphical, 18-25
 Difference between isothermal and adiabatic compression, 22
 Direct acting steam compressor, 82
 Disc fan, 58
 Discharge from a fan, 57, 59, 66
 valve, 102

- Discharge, area, 101
 Draft measurement, 43
 Dresser coupler, 172
 Dry air, 4
 pump, 27
 Duplex compressor, 86
 cross compound steam, two-stage
 air compressor, 88
 belt driven compressor, 87
 steam driven compressor, 87
 Durley, R. J., 166

 Economic efficiency, 81
 Edwards air pump, 31
 Effect of altitude, 140-144
 of clearance, 70, 71, 96, 97
 of changing discharge pressure, 99
 of early closing of inlet valve, 73
 of pressure on temperature, 4
 Effects of heat, 6
 of outlet on capacity, 55
 Effects of pressure on temperature, 4
 Efficiency, apparent volumetric, 77
 blower, 81
 cylinder, 80
 economic, 81
 of compression, 80
 of fans, 45
 of Taylor compressor, 134
 Efficiencies, 77-82
 true volumetric, 80
 Efflux, coefficient of, 43, 56
 Electric meter, diagram, 169
 Energy, 5
 compensation, 82-88
 in air, 6
 Engineering Magazine, 113
 Equalizing steam pressure and air
 resistance, 82
 Equilateral hyperbola, 18, 19
 External energy changes, 6
 Expansion of casing, 118
 Explosions, compressed air, 182
 Exponential compression, 23
 curve construction, 19

 Fan, blast or steel plate, 60
 capacity, 42
 Fan, centrifugal, 38-65
 cone wheel, 65-66
 definitions, 42
 design, 58-67
 description, 58
 discharge, 58, 59, 66
 efficiency, 45
 losses, 45
 mechanics of, 52
 pressure, 42
 proportions, 41, 61
 radial wheel, 58
 speed, 62, 67
 Fans, axial, 41
 classification of, 41
 or blowers, 41
 Flow of gas through an orifice, 45, 46
 Forges, air required, 39
 Forms of poppet valves, 101
 Free air, 2
 discharge, 42
 Friction effect of elbows, 61, 176
 Frizell, J. P., 129
 Frizell's compressor, 129
 Fundamental definitions, 5-9

 Gases in air, 1
 Governor and regulator combined, 109
 Clayton, 109
 for electric driven compressors,
 107
 Nordberg, 109, 110
 Grains, vapor per cu. ft. saturated air, 2
 Graphical construction of exponential
 curve, 18, 19
 of isothermal curve, 18, 19
 diagrams, 18-25
 method of determining mean
 head, 165

 Halsey, F. A., 142
 Hammon coupler, 172, 173
 Heat, 5
 added or taken away for iso-
 thermal change, 21
 for exponential change, 21
 effects, 6
 taken away during compression,
 22

- Hero's device for opening temple doors, VII
 fountain, VII
 Horse-power, brake for fans, 58, 60, 66
 single-stage compression, 74
 Horizontal-vertical arrangement of cylinders, 86
 Housing for fans, 42-63
 Humidity, absolute, 191
 of air, 1, 2, 3, 55
 Hydraulic air compression, 129-139
 air pump, 26
 compensator, 83
 compression losses, 138
 compressor, Arthur's, 132
 Baloche and Krahnass, 131, 132
 Taylor's, 133-137
 Hygrometry, 191

 Ideal card, piston compressor, 77
 Impellers, rotary blowers, 49, 50
 Improved cooling, turbo-compressors, 118
 Indicator card piston compressor, 70
 cards, condenser pumps, 30
 Industrial uses vacuum, 32
 Ingersoll Rand Co., 103, 111, 112
 compressor, 147
 Inlet connection, 183
 for blowing fan, 61
 for exhaust fan, 61
 valve, 101
 area, 100
 setting, 101
 Intercoolers, 90
 capacity, 93
 Nordberg, 92
 pressure, 93
 surface required, 93
 types, 92
 tubes, 92
 with separator, 92
 Internal energy changes, 6
 or intrinsic energy of air, 7
 computation of, 16

 Jaeger, C. H., 118
 Jaeger's turbo-blower, 119
 patent impeller, 120
 Kennedy blowing engine valve, 105
 Kowalke, O. L., 191
 Krahnass, A., 131

 Labyrinth bushing, 120
 Law, Boyle's, 10
 of Charles, 10
 Leakage past turbo-stages, 120
 Lecture by H. deB. Parsons on fans, 41-68
 Lever compensation, 83, 84
 Leyner air reheater, 177
 Liquors, concentration of, 34
 Logarithms, common, 184-186
 Naperian, 188-190
 Loss of capacity due to clearance, 79
 of head due to friction in ducts, 47
 Losses of blower, 81
 of hydraulic compression, 138
 Low pressures, compressors, 38
 Lubricating compressors, 182

 Marks and Davis condensed steam tables, 193-198
 Measurement of compressed air, 160-171
 of draft, 43
 of large quantities of air, 166
 Measuring vacuums, 27
 Mechanical efficiency, 81
 valve of Corliss type, 104
 valves, 98
 Mechanically operated discharge valve, 100
 Mechanics of the fan, 52
 Mercurial air pump, 26
 Meter comparisons, 170
 test results, 171
 Methods of reducing clearance, 71
 Mines and Minerals, 144
 Mixing blower, 127
 Mode of conducting tests, 147
 Modern form of Pitot tube, 162
 Moisture precipitated from air, 3
 Mt. Cenis tunnel, VIII
 Multi-stage compression, 97
 advantages, 90

 Naperian logarithms, 188-190

- Net efficiency, 81
 Nordberg compressor test, 144
 governor, 109-110
 intercooler, 92
 Mfg. Co., 109
 Norwalk compressor, 84
 regulator, 108
 Notation of symbols for fan formulæ,
 47
 Numerical value of R, 10

 Orifice, flow of gas in, 45, 46
 Oxygen in air, 1
 in hydraulic compressed air, 137

 Parsons, H. deB., 41-68
 blower, 114
 blades, 115
 Partial pressures, 198
 Peele, Robert, 140
 Perfect gas, characteristic equation,
 10
 intercooling, 93
 Peripheral speed of fans, 62, 67
 Phenomena of hydraulic air compression,
 137
 Pipe couplers, 172, 173
 formulæ, constants, 174, 175
 lines, 171-176
 line formulæ, 173
 losses, ducts, 48
 Piston, balancing, 123
 -balanced turbo-compressor, 122
 compression, hydraulic, 72
 three-stage diagram, 116
 compressor action, 70
 cross-section, 69
 details, 98-112
 compressors, 69-77
 controlled by multiplier, 126
 -inlet valve, 102, 108
 Pitot tube, 161, 162
 Pounds of water precipitated per cu.
 ft. cooled air, 3
 Power, 5
 available, 179
 consumed by rotary and piston
 compressors, 52
 for rotary blowers, 51

 Pressures, blower, 50
 oz. per sq. in. in water head to
 inches, 44
 used for various stages, 90
 water column in inches to oz.
 per sq. in., 44
 Proper receiver pressure for multi-
 stage compression, 96
 Propeller fan, 58
 Proportions of fans and housing, 41, 61
 of rotary blowers, 50
 Psychrometers, 192
 Pump, dry air condenser, 26
 Pumps, condenser, 26-30

 R, numerical value, 10
 Radial wheel fan, 58
 Railway and Engineering Review, 130
 Rand Imperial unloader, 111
 Rateau blower, 114
 multiplier, 125
 turbo-compressor, 128
 Ratio of air cylinder to low-pressure
 steam cylinder, 29
 of air cylinder to volume of con-
 densed steam, 29
 of port to cylinder area, 100
 Real specific heat, 8
 Receiver aftercoolers, 159
 intercoolers, 92
 capacity, 160
 Receivers, 159
 Regulator, belt, 105, 107
 and governor combined, 109
 Norwalk, 108
 Regulators and unloading devices,
 105
 Relation between altitude and volume,
 141
 specific heats, 10
 Relations between P, v and T for
 adiabatic and exponentia
 changes, 16
 Relative humidity, 192
 Restricted discharge, 42
 Results of meter tests, 171
 of tests, 148
 Richards, Frank, 175
 Right-angle bend resistance, 49

- Robinson, S. W., 163
 Rotary blowing machines, 49
 blowers, proportions, 50
 Rooms, air required, 40
 Rowse, S. W., 200
 Runners, 119
- Salt evaporating effects, 32
 Sangster, Wm., 39
 Schmidt, Henry F., 81
 Sectional view of Thomas electric meter, 168
 Selection of air compressors, 179-182
 Semi-mechanical valves, 103
 Shape of fan blades, 58, 61, 66, 67
 Simple form of Pitot tube, 161
 Single-stage compression, horse-power required, 74
 Sirocco double inlet fan, 68
 Size and type of compressor, 181
 of water and air pumps, 28
 Sketch of meters placed tandem for testing, 170
 Sommeiller's compressor, IX
 Southwork blowing engine valve, 104
 Specific heat, 7
 apparent, and real, 8
 at constant pressure, 7
 at constant volume, 7
 at various pressures and temperatures, 8
 volume of water vapor, 193-198
 Speed of fans, 58, 62, 67
 of turbo-compressors, 113
 Sperr, F. W., 136
 Sprengle air pump, 26
 St. John's meter, 166
 Standards of measurement, 160
 Steam cylinder size, 30
 Steel plate fans, 61, 64
 Straight line compressor, 84
 Stuffing boxes, 123
 Suction line, 73
 Surface of intercoolers, 93
 Sullivan air reheater, 177
 Mch. Co., 177, 181
 Summary of tests, 157
 Syphon, 37
 bulk head, 131
- Taylor, Charles H., 133
 compressor, 133
 efficiency, 134
 at Ainsworth, B. C., 135
 at Magog, Quebec, 134
 at Victoria mine Michigan, 136
 Temperature, 5
 absolute, 5
 Temperatures due to adiabatic compression, 22, 23
 Test curves, Jaeger's turbo-blower, 124
 of hydraulic compressor, 136
 of plant No. 1, 148-151
 of plant No. 2, 151-154
 of plant No. 3, 154-156
 of plant No. 4, 156-157
 Tests, mode of conducting, 147
 Thomas, C. C., 160
 meter, 168
 diagram, 169
 Three-quarter housed steel plate fan, 64
 Tightness between stages, 120
 Towl, Forrest, M., 160, 171
 Trompe, 129
 True volumetric efficiency, 80
 Turbine blast or Sirocco fan, 67
 Turbo-blower coupling arrangements, 125
 of 25,000 cu. ft., 121
 of 140,000 cu. ft. capacity, 128
 Turbo-compressor cooling, 115
 design, 113
 diagram, 116
 for mixing air and gas, 128
 Jaeger's, 119
 Parson's, 114
 Turbo-compressors, 113-128
 Two-stage compressor cards, 147
 Types of blading, 68
- U. S. Navy pump, 30
 Uncovering port to release clearance pressure, 71
 Unloader, clearance, 110, 112
 Rand Imperial, 111
 Unloading devices, 110
 Uses of air at low pressures, 38
 Usual velocity in ducts, 47

- Vacuum cleaners, 36
 - concentration of liquors, 34, 35
 - manufacture of salt, 32
 - measurement, 27
- Valve area, 100
 - of discharge, 101
 - gear, 179
 - in cylinder head, 102
 - mechanical, 98
 - poppet, 101
 - piston-inlet, 102
 - setting, 101
 - semi-mechanical, 103
- Valves, area of inlet, 100
 - automatic, 100
 - classification, 98
 - cleaning, 182
- Vapor in air, 1
- Velocity, coefficient of, 43
 - of air through ports, 101
 - meters, 161
- Ventilation, air required, 39, 40
- Venturi meter, 167
 - vacuum pump, 26
- Volumetric efficiency, 77
 - apparent, 77
 - true, 80
 - meters, 160
- Water, air in, 29
- Water-cooled turbo-compressor, 117, 118
- Water measurements, hydraulic compressor tests, 137
 - precipitated from compressed air, 3
 - present in saturated air, 2, 55
 - required for intercooler, 94
- Webb, Richard, L., 146
- Weight compensation, 83
 - of air, 10
- Westinghouse air pump, 85
 - governor, 106
- Wet air pump, 27
 - displacement meter, 160
 - and dry compression, 74
- Weymouth, Thos. R., 164
- Wheeler combined pump, 27
 - condenser pump, 28
- Work, 5
 - done by a compressor, 23
 - of adiabatic change, 15
 - of exponential change, 14
 - of isothermal change, 12
 - required to move a volume of gas 56
- Zero, absolute, 6
- Zur Nedden, Franz, 81, 113

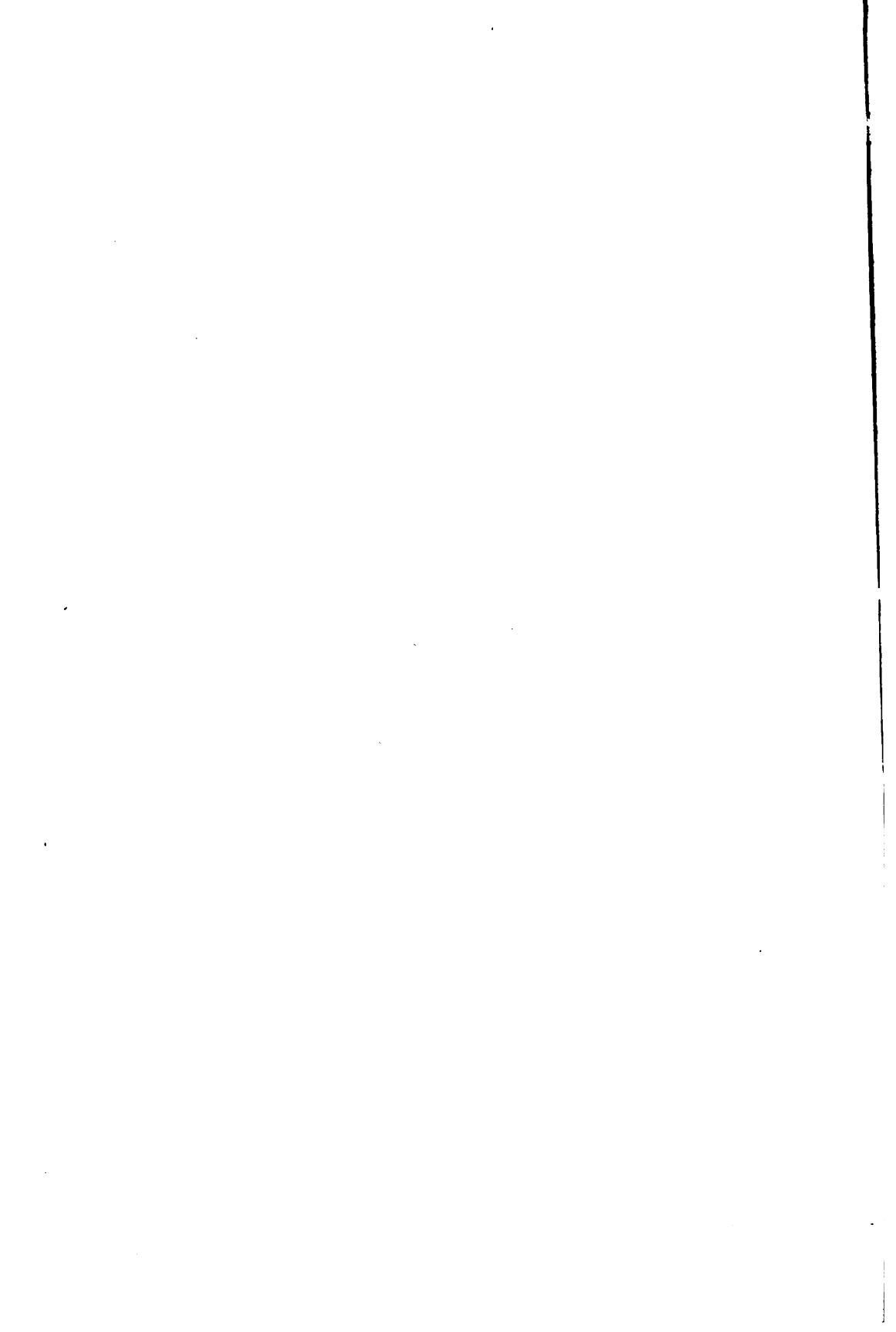



89067737312



B89067737312A

666074

TEP
T39
.2

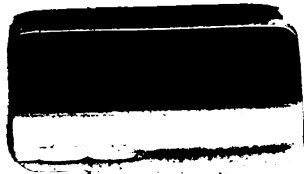

89067737312



b89067737312a